

~~MC 8508~~
A9 7302
~~clump~~

Veron Bibliotheek
Postbus 220
5670 AE Nuenen

38 MAINTENANCE MANUAL 343
VOL 1

TECHNICAL MANUAL
38 AUTOMATIC SEND-RECEIVE (ASR)
TELETYPEWRITER SET



TELETYPE[®]
CORPORATION
5555 TOUHY AVENUE, SKOKIE, ILLINOIS

**MAINTENANCE MANUAL 343
VOLUME 1**

INTRODUCTION

Maintenance Manual 343 is a technical manual that provides general and specific information about the 38 Automatic Send-Receive (ASR) Teletypewriter Set and its components.

Maintenance Manual 343 is made up of 3 Volumes: Volume 1 contains description, troubleshooting, lubrication, disassembly and reassembly. Volume 2 contains adjustments and Volume 3 contains parts.

Each volume is made up of independent sections identified by a 9-digit number, such as the first section in this volume numbered 574-400-100TC.

To locate specific information, refer to the table of contents. Find the name of the component in column one and the title in column two. The 9-digit section will then be found in column three. The sections are arranged in the order shown in the table of contents.

Each section in this manual may be ordered separately, by 9-digit number, from Teletype Corporation.

TABLE OF CONTENTS

| <u>Equipment</u> | <u>Content</u> | <u>Section</u> | <u>Issue</u> |
|-------------------------|-----------------------------------------|----------------|--------------|
| Teletypewriter Set | General Description and Operation | 574-400-100TC | 2* |
| | Troubleshooting | 574-400-300TC | 2* |
| | Removal and Replacement of Components | 574-400-702TC | 2* |
| Keyboard | Description and Principles of Operation | 574-421-100TC | 2* |
| | Lubrication | 574-421-701TC | 2* |
| | Disassembly and Reassembly | 574-421-702TC | 1 |
| Printer | Description and Principles of Operation | 574-422-100TC | 2* |
| | Lubrication | 574-422-701TC | 2* |
| | Disassembly and Reassembly | 574-422-702TC | 1 |
| Electrical Service Unit | Description and Operation | 574-423-100TC | 2* |
| | Disassembly and Reassembly | 574-423-702TC | 2* |
| Reader | Description and Principles of Operation | 574-424-100TC | 1 |
| | Lubrication | 574-424-701TC | 2* |
| | Disassembly and Reassembly | 574-424-702TC | 1 |
| Punch | Description and Principles of Operation | 574-425-100TC | 1 |
| | Lubrication | 574-425-701TC | 2* |
| | Disassembly and Reassembly | 574-425-702TC | 2* |
| Cover | Lubrication | 574-426-701TC | 1 |

38 AUTOMATIC SEND-RECEIVE (ASR) SET
GENERAL DESCRIPTION AND OPERATION

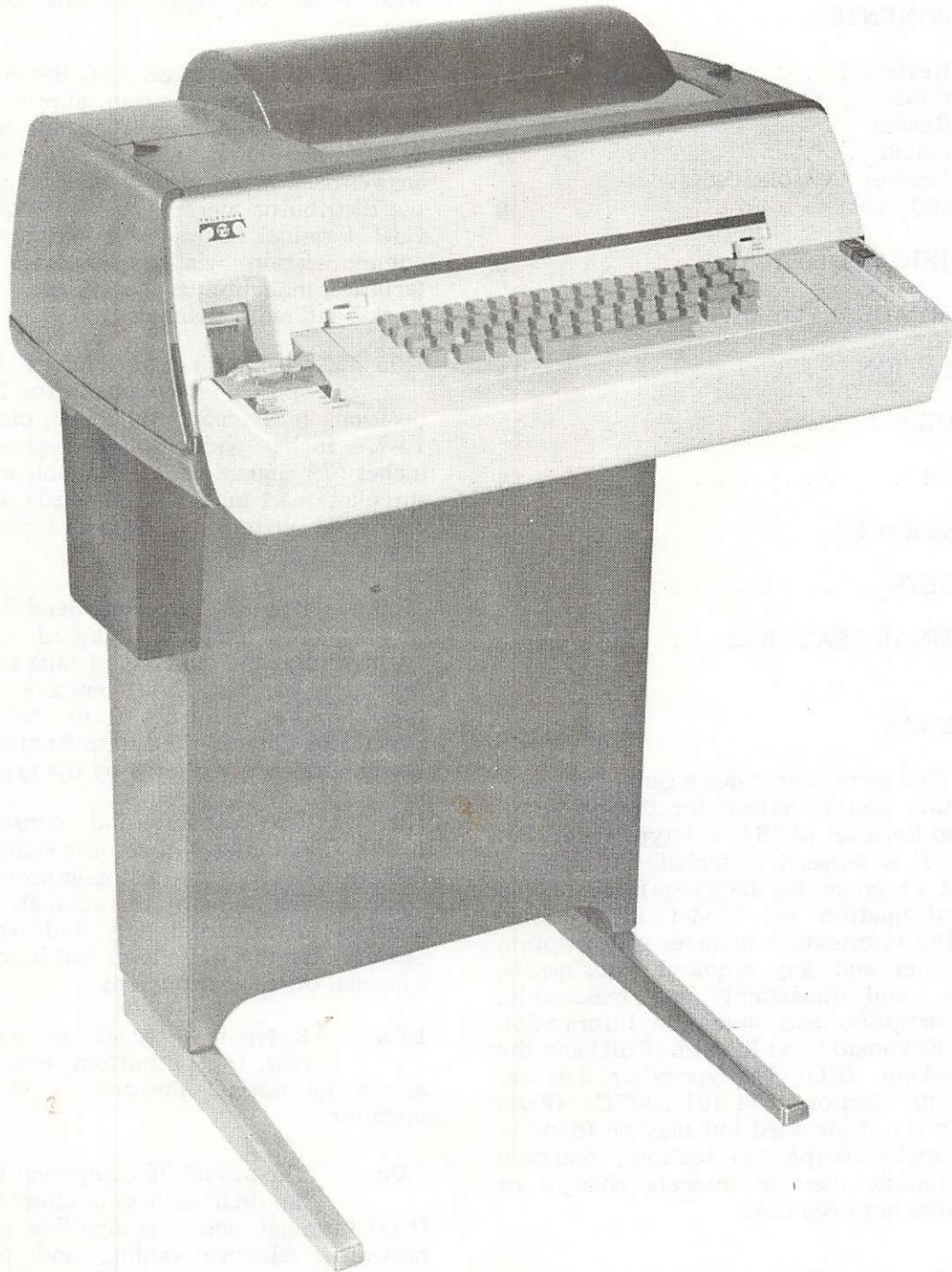

Figure 1 - 38 Automatic Send-Receive (ASR) Set

| CONTENTS | PAGE |
|------------------------------------------------------|------|
| 1. GENERAL | 2 |
| 2. DESCRIPTION | 4 |
| STANDARD FEATURES | 4 |
| ELECTRICAL SERVICE UNIT | 5 |
| COMPONENTS | 5 |
| A. Keyboard | 5 |
| B. Printer | 7 |
| C. Reader | 7 |
| D. Punch | 7 |
| E. Cabinet, Console, Pedestal and Table | 9 |
| 3. TECHNICAL DATA | 9 |
| 4. INTERFACE INFORMATION | 11 |
| 5. OPERATION | 13 |
| READER | 17 |
| PUNCH | 18 |
| 6. REFERENCES | 18 |
| 7. APL SETS | 19 |
| 8. OPTIONAL FEATURES | 23 |

1. GENERAL

1.01 This section provides a general description and operation for the 38 Automatic Send-Receive (ASR) Teletypewriter Set (Figure 1). It is reissued to include information on APL (A Programming Language) Sets and to provide information on Model 38 optional features. The information includes a description of the option and any required adjustments, lubrication, and disassembly and reassembly. General description and operation information for the 38 Keyboard Send-Receive (KSR) and the 38 Receive-Only (RO) Teletypewriter Sets are contained in Section 574-401-100TC. (Parts information is not included but may be found in the appropriate component section.) Marginal arrows ordinarily used to indicate changes or additions have not been used.

1.02 The 38 ASR Set is capable of transmitting or receiving data over switched voice grade facilities or private wire facilities at speeds up to 110 baud (100 words per minute).

Depending on option programming, the set operates on half-duplex (HDX) or full-duplex (FDX) transmission facilities.

1.03 The signaling code is the ASCII (X3.4-1968) (American National Standard Code for Information Interchange). These units are capable of generating 128 characters using an 8-level code composed of seven data bits and one parity bit. A single character is generated with a start bit, eight data bits, and a two-unit stop bit.

1.04 The Model 38 ASR Set is composed of an electromechanical printer, keyboard, paper tape punch, and paper tape reader (Figure 2). Station identification is provided by an answer-back mechanism that is an integral part of the distributor mechanism. This equipment provides terminal facilities for exchanging recorded communication via appropriate transmission facilities, including telegraph lines, telephone networks, and radio channels.

1.05 The typing unit has a 15-inch wide sprocket feed platen for 132 character positions that accommodate fanfold paper stock 14-7/8 inches wide. Standard platens of 8-1/2 inches (72 characters) are available in friction and sprocket feed units. The horizontal spacing for the wide platen and standard platens are 10 characters per inch.

1.06 The 38 Automatic Send-Receive (ASR) Set provides keyboard entry into the typing unit, tape punch, and tape reader. On-line operation transmits data manually from the keyboard or automatically from the reader using paper tape. Transmitted data from the reader can be simultaneously printed by the typing unit.

1.07 The cabinet and console may be mounted either on a standard pedestal (Figure 1) or on the customer-provided table or counter. The color of the cabinet, console, and pedestal are charcoal gray and ivory. The set operates at a low noise level that is comfortable in a normal office environment.

1.08 References to left or right, front or rear, top or bottom, etc, apply to the set in its normal position as viewed by the operator.

1.09 The Model 38 equipment is designed to be used as a computer Input-Output (I/O) terminal, and is compatible with switched network, selective calling, and point-to-point private line services. The ESU (Electrical Service Unit) is available, that contains a data modem (data set), as an integral part of the unit. The modem contains a frequency shift that is auto-

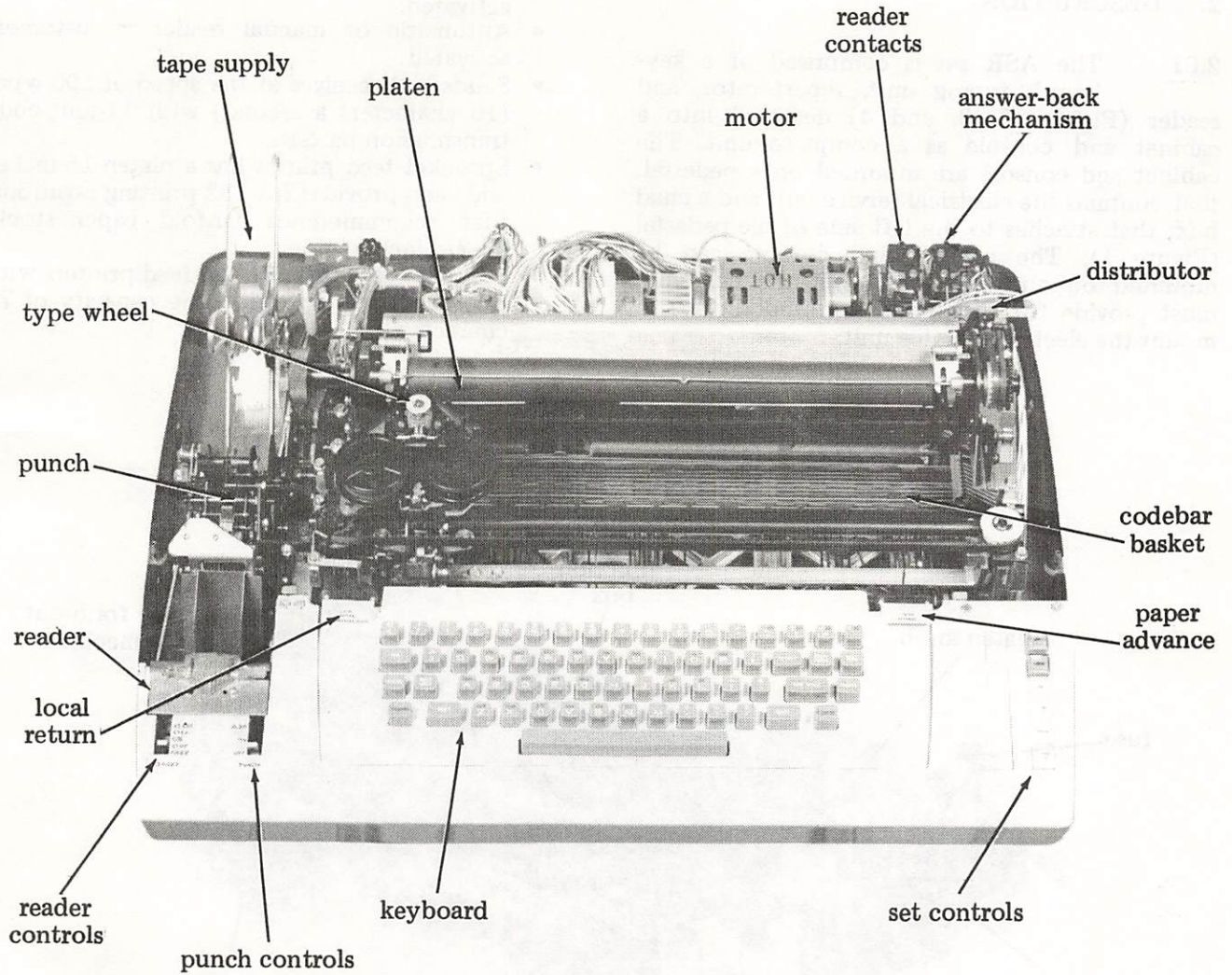

Figure 2 - 38 Automatic Send-Receive (ASR) Set With Cover Removed

matically operated when the set goes on-line. This modem is compatible with WECO 101, 103, and 113 Data Sets or equivalent. The modem and data access arrangements enable the transmission over voice grade telephone lines.

1.10 The Data Access Arrangement (DAA) is required when a customer uses his own modem. This arrangement is provided by the local Telephone Company as part of the contract for use of the telephone network. The reason for this additional unit is to protect other users on the network.

2. DESCRIPTION

2.01 The ASR set is comprised of a keyboard, typing unit, reperforator, and reader (Figures 2, 3, and 4) designed into a cabinet and console as a complete unit. The cabinet and console are mounted on a pedestal, that contains the electrical service unit and a chad box, that attaches to the left side of the pedestal (Figure 1). The cabinet and console can be mounted on an office desk, but the customer must provide for chad collection and a place to mount the electrical service unit.

STANDARD FEATURES

2.02 The following features are standard on ASR sets:

- A 4-row keyboard that generates all 128 ASCII characters.
- Sends on-line through tape reader or through keyboard.
- Receives all 128 ASCII characters — prints 94 graphics including upper and lower case alphabet except, space and delete.
- Receives through typing unit or reader unit.
- Automatic or manual punch — customer-activated.
- Automatic or manual reader — customer-activated.
- Sends and receives at the speed of 100 wpm (10 characters a second) with 11-unit code transmission pattern.
- Sprocket feed printer has a platen 15 inches wide and provides for 132 printing positions, that accommodates fanfold paper stock, 14-7/8 inches wide.
- Sprocket feed and friction feed printers with 8-1/2 inch platens with line capacity of 72 characters.

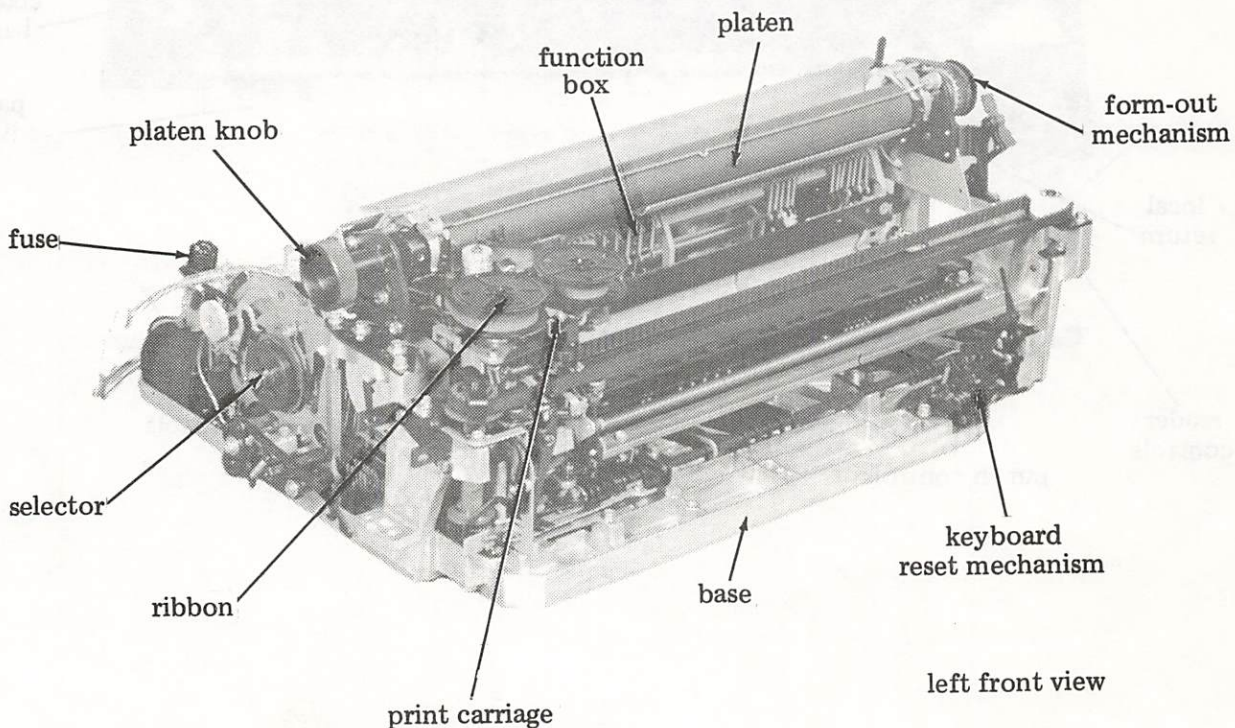
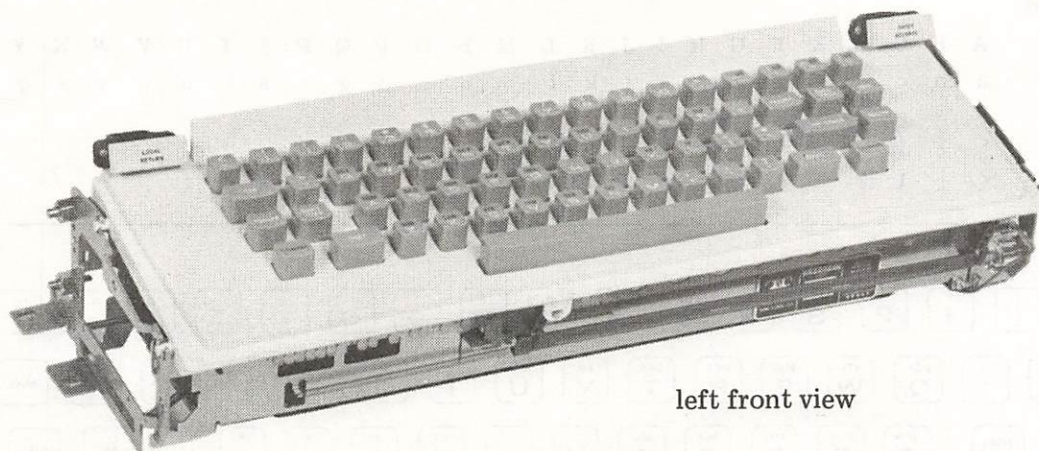

Figure 3 - 38 Printer



left front view

Figure 4 - 38 Keyboard

- Two-color printing — red and black.
- Automatic carriage return and line feed on 132nd character — customer-activated option (for Wide Platen Sets).
- Tape storage for a full roll of 1000 feet of 1 inch paper tape.
- Answer-back triggered either automatically from data modem or data set, upon receipt of ENQ character, or manually with HERE IS key.
- Motor — 50 or 60 Hz.
- Vertical line spacing — single or double (6 or 3 lines per inch).
- Form feed of 11-inch or 5-1/2 inch — customer-activated option.
- Full- or half-duplex mode — customer-activated option.
- Printing in all capitals in the unshift mode — customer-activated option.
- Repeat feature of any key on the keyboard generates the character continuously (Customer-Activated).
- Suppress on disable
- Automatic frequency shift modulation
- 100 words per minute (110 baud)
- Transmission serially by bits
- Manual data access

COMPONENTS

A. Keyboard

2.05 The 38 keyboard is capable of generating 128 ASCII characters and presenting them in parallel wire form to the transmitter distributor that converts the code to serial form for the typing unit, reperforator, reader, or to be sent over the signal line.

2.06 The keyboard has 4 rows similar to the standard typewriter. Figure 4 shows a typical arrangement. This keyboard has a repeatable key feature that permits any key that is depressed beyond the normal stop position to continuously repeat that key until it is released. The keyboard console has a manual local carriage return button on the left, and a manual paper advance button on the right, refer to Figure 2. Figures 5, 6, and 7 show the three typical keyboard arrangements and their associated type wheel character sets for Model 38 equipment.

2.07 The keyboard interlock prevents the depression of two keys simultaneously with the exception of the SHIFT or CONTROL key. The CONTROL key and code keys are designated on the keytops by darker characters. The control codes are generated by holding the CONTROL key depressed while depressing one of the symbols or characters related to the control codes.

ELECTRICAL SERVICE UNIT

2.03 Two electrical service units are available for ASR sets:

- Provides interfacing that conforms with EIA (Electronic Industries Association) Standard RS-232-C interfacing and provides 20 ma or 60 ma dc neutral signal line.
- Incorporates in the ESU, a data modem, having both originate and answer modes.

2.04 The ESU that provides a data modem has the following features:

- Half- or full-duplex mode
- Sending on echoplex

AD TYPE WHEEL CHARACTER SET

| | | | | | | | | | | | | | | | | | | | | | | | | | | | |
|----------|---|---|---|---|---|----|---|---|---|---|---|---|---|---|---|---|---|---|---|---|---|---|---|---|---|---|---|
| POSITION | | A | B | C | D | E | F | G | H | I | J | K | L | M | N | O | P | Q | R | S | T | U | V | W | X | Y | Z |
| SHIFT | | A | B | C | D | E | F | G | H | I | J | K | L | M | N | O | P | Q | R | S | T | U | V | W | X | Y | Z |
| UNSHIFT | | a | b | c | d | e | f | g | h | i | j | k | l | m | n | o | p | q | r | s | t | u | v | w | x | y | z |
| SHIFT | < | { | ! | " | # | \$ | % | & | ' | (|) | = | _ | } | ~ | | > | \ | + | * | , | . | ? | | | | |
| UNSHIFT | < | [| 1 | 2 | 3 | 4 | 5 | 6 | 7 | 8 | 9 | 0 | - | _ |] | ^ | \ | > | @ | ; | : | , | . | / | | | |

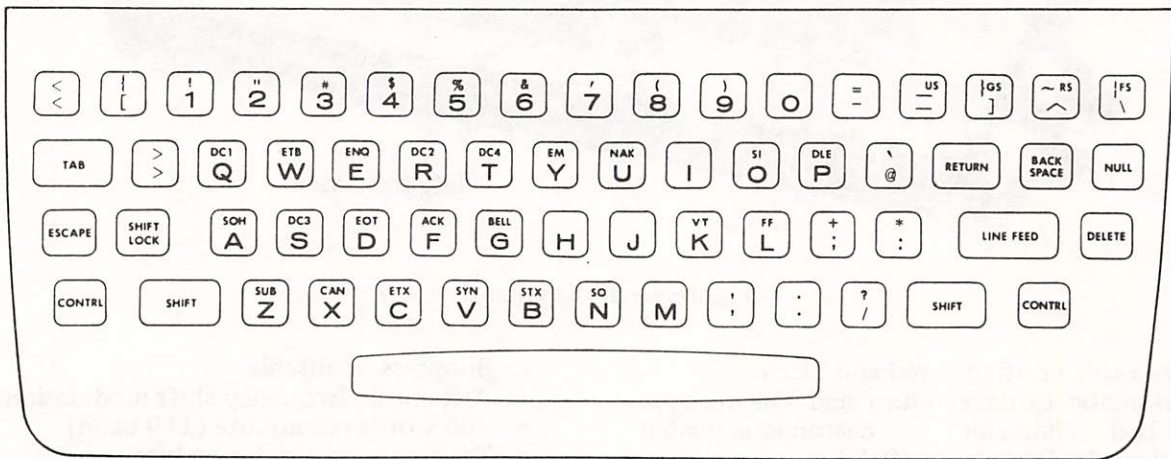

Figure 5 - AAW Keyboard Arrangement

AF TYPE WHEEL CHARACTER SET

| | | | | | | | | | | | | | | | | | | | | | | | | | | | |
|----------|---|---|---|---|---|----|---|---|---|---|---|---|---|---|---|---|---|---|---|---|---|---|---|---|---|---|---|
| POSITION | | A | B | C | D | E | F | G | H | I | J | K | L | M | N | O | P | Q | R | S | T | U | V | W | X | Y | Z |
| SHIFT | | A | B | C | D | E | F | G | H | I | J | K | L | M | N | O | P | Q | R | S | T | U | V | W | X | Y | Z |
| UNSHIFT | | a | b | c | d | e | f | g | h | i | j | k | l | m | n | o | p | q | r | s | t | u | v | w | x | y | z |
| SHIFT | < | { | ! | " | # | \$ | % | & | ' | (|) | = | _ | } | ~ | | > | \ | + | * | , | . | ? | | | | |
| UNSHIFT | < | [| 1 | 2 | 3 | 4 | 5 | 6 | 7 | 8 | 9 | ø | - | _ |] | ^ | \ | > | @ | ; | : | , | . | / | | | |

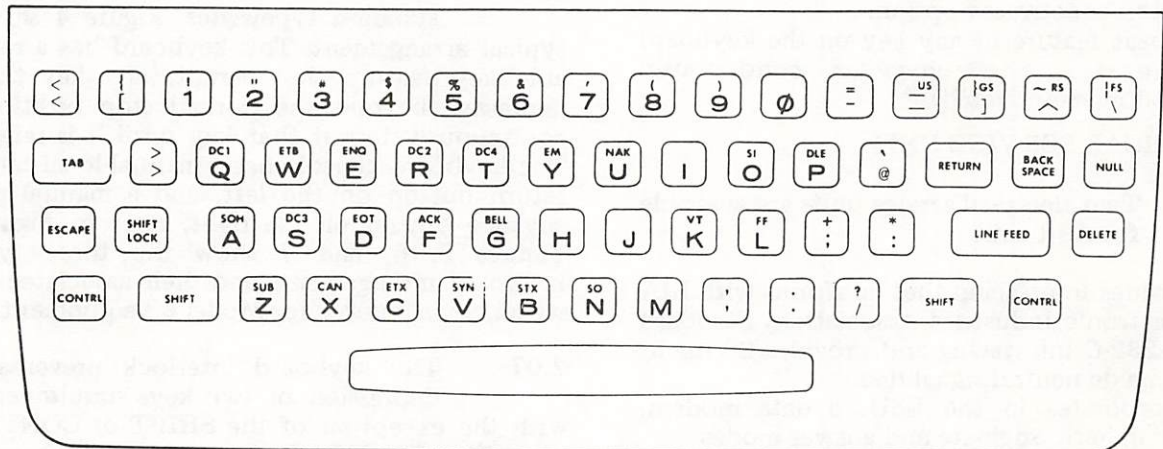

Figure 6 - ABW Keyboard Arrangement

AG TYPE WHEEL CHARACTER SET

| | |
|-----------------|-----------------------------------------------------|
| POSITION | |
| SHIFT | A B C D E F G H I J K L M N O P Q R S T U V W X Y Z |
| UNSHIFT | a b c d e f g h i j k l m n o p q r s t u v w x y z |
| SHIFT | < { ! " # \$ % & ' () = _ } ~ > \ + * , . ? |
| UNSHIFT | < [1 2 3 4 5 6 7 8 9 0 - _] ^ \ > @ ; : , . / |

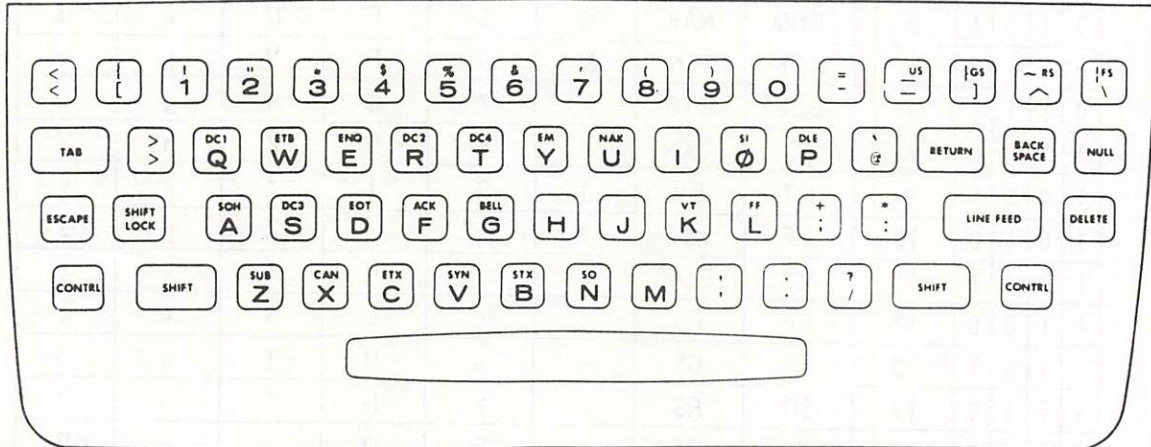

Figure 7 - ACW Keyboard Arrangement

B. Printer

2.08 The typing unit (Figure 3) is capable of receiving and printing up to 94 graphics (Figure 8) on a parity insensitive basis. The typing unit can be programmed for one or two line spaces, per line feed (LF) signal, by activating a mechanical rocker switch on the right side of the typing unit. Platens of 8-1/2 inches (72 characters) are available in friction or sprocket feed. These platens fit into the standard wide platen cover and are mounted to the left which enables the punch and reader to couple into the typing unit.

2.09 A low-paper or paper-out indication is provided on friction and sprocket feed machines respectively. Automatic carriage return and line feed is incorporated into the typing units to return printing to the left margin when the standard line length is exceeded.

C. Reader

2.10 The Model 38 tape reader (Figure 9) is a parallel wire transmitter with electro-mechanical drive for its read-feed cycle. Speed is controlled at 10 characters per second by the typing unit distributor mechanism. The reader

conforms to ASCII-1968 for one inch wide fully perforated tape.

2.11 The reader can be programmed by a strapping option to operate in manual or automatic mode. The automatic mode responds to the reception of a DC1 character in the typing unit function box. The tape can be manually pulled through the reader for positioning or advanced one character by the control switch on the side of the reader.

D. Punch

2.12 The punch (Figure 10) operates at 100 words per minute (10 characters per second) and provides fully perforated 8-level, 1-inch wide tape that conforms to ASCII-1968.

2.13 The features of this unit are manual or automatic operation. The punch controls extend out from the keyboard cover and the chad box mounts to the underside of the cabinet.

2.14 Two mechanical inputs provide power to drive the punch block and tape feed mechanism, and another input that provides code transfer from the codebar basket on the typing unit, through codebar extensions, to the reperfector sensing levers.

| Bits | | | | | 0 0 | 0 0 1 | 0 1 0 | 0 1 1 | 1 0 0 | 1 0 1 | 1 1 0 | 1 1 1 | | | | |
|----------------|----------------|----------------|----------------|----------------|----------------|----------------|--------|-------|-------|-------|-------|-------|---|---|---|-----|
| b ₇ | b ₆ | b ₅ | b ₄ | b ₃ | b ₂ | b ₁ | COLUMN | ROW | 0 | 1 | 2 | 3 | 4 | 5 | 6 | 7 |
| 0 | 0 | 0 | 0 | 0 | 0 | 0 | 0 | 0 | NUL | DLE | SP | 0 | @ | P | ' | p |
| 0 | 0 | 0 | 0 | 1 | 0 | 0 | 1 | 1 | SOH | DC1 | ! | 1 | A | Q | a | q |
| 0 | 0 | 1 | 0 | 0 | 0 | 0 | 2 | 2 | STX | DC2 | " | 2 | B | R | b | r |
| 0 | 0 | 1 | 1 | 0 | 0 | 0 | 3 | 3 | ETX | DC3 | # | 3 | C | S | c | s |
| 0 | 1 | 0 | 0 | 0 | 0 | 0 | 4 | 4 | EOT | DC4 | \$ | 4 | D | T | d | t |
| 0 | 1 | 0 | 1 | 0 | 0 | 0 | 5 | 5 | ENQ | NAK | % | 5 | E | U | e | u |
| 0 | 1 | 1 | 0 | 0 | 0 | 0 | 6 | 6 | ACK | SYN | & | 6 | F | V | f | v |
| 0 | 1 | 1 | 1 | 0 | 0 | 0 | 7 | 7 | BEL | ETB | ' | 7 | G | W | g | w |
| 1 | 0 | 0 | 0 | 0 | 0 | 0 | 8 | 8 | BS | CAN | (| 8 | H | X | h | x |
| 1 | 0 | 0 | 1 | 0 | 0 | 0 | 9 | 9 | HT | EM |) | 9 | I | Y | i | y |
| 1 | 0 | 1 | 0 | 0 | 0 | 0 | 10 | 10 | LF | SUB | * | : | J | Z | j | z |
| 1 | 0 | 1 | 1 | 0 | 0 | 0 | 11 | 11 | VT | ESC | + | ; | K | [| k | { |
| 1 | 1 | 0 | 0 | 0 | 0 | 0 | 12 | 12 | FF | FS | , | < | L | \ | l | |
| 1 | 1 | 0 | 1 | 0 | 0 | 0 | 13 | 13 | CR | GS | - | = | M |] | m | } |
| 1 | 1 | 1 | 0 | 0 | 0 | 0 | 14 | 14 | SO | RS | . | > | N | ^ | n | ~ |
| 1 | 1 | 1 | 1 | 0 | 0 | 0 | 15 | 15 | SI | US | / | ? | O | _ | o | DEL |

Figure 8 - ASCII Code Chart

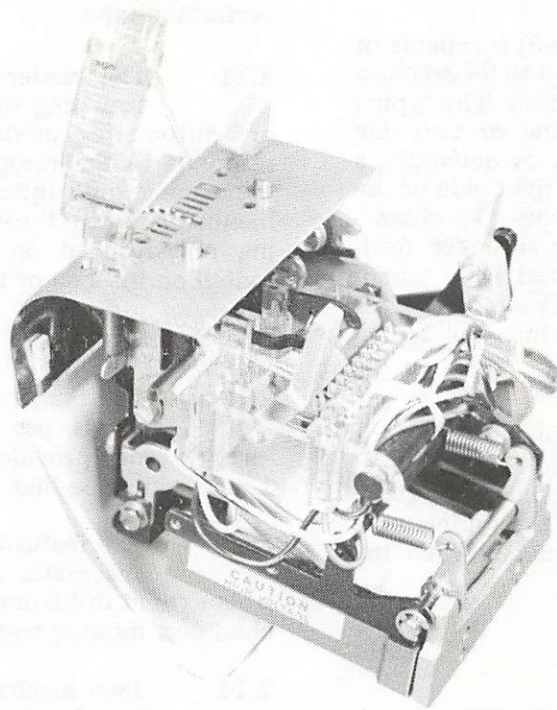

Figure 9 - 38 Reader

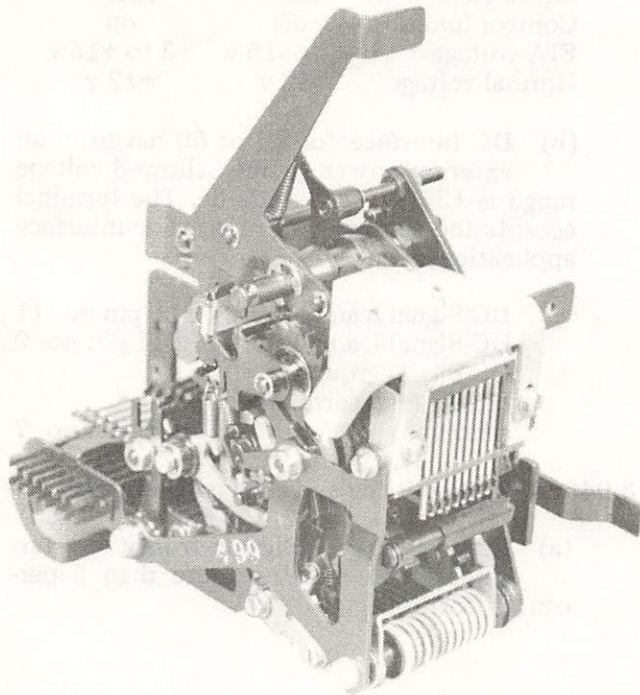

Figure 10 - 38 Punch

E. Cabinet, Console, Pedestal, and Table

2.15 The cabinet and console are contemporary in design for both styling and functionally to provide low operating sounds for a comfortable work environment. The cabinet and console are charcoal gray and ivory, the pedestal is charcoal gray with stainless steel feet (Figure 1). The typing unit, motor, perforator, reader, and keyboard are housed in the cabinet and console. The pedestal contains the electrical service unit and mounting for the cabinet and console, form accumulator, and fanfold rack.

2.16 The cabinet and console may be mounted on a customer-provided table or counter. If a customer's table is used, provisions for the electrical service unit and the chad box must be made by the customer.

2.17 As an option, a double-compartment table (Figure 11) is available when a table style of furniture is desired, or when additional electrical equipment is required, such as the station controller. This additional electrical equipment can be mounted behind the front panel or in the right pedestal. A right pedestal door is available that has provisions for an attendant set.

3. TECHNICAL DATA

3.01 Electrical and Environmental Characteristics

- (a) Power 115 volts ac $\pm 10\%$,
50 or 60 Hz ± 0.5 Hz,
3 ampere fused circuit,
single phase (3-wire)
- (b) Power consumption 300 watts
- (c) Temperature ranges This equipment is intended to be operated in a room environment within the temperature range of 40°F to 110°F. Serious damage to it could result if this range is exceeded. In this connection, particular caution should be exercised in using acoustical or other enclosures.
- (d) Ambient relative humidity From 0 to 95 percent
- (e) Storage temperature -40°F to 150°F

3.02 Physical Characteristics

- (a) Dimensions See Figure 12
- (b) Weight 98 pounds: 105 pounds with pedestal

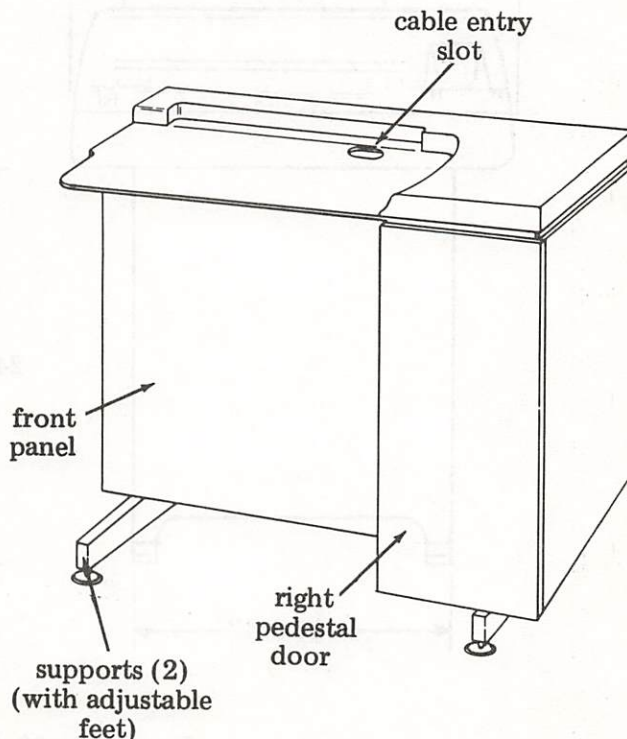

Figure 11 - Double-Compartment Table

- (c) Power cord
 - Purpose Provides ac power for entire set
 - Type Single 3-pin polarized cord
 - Length 8 feet from back of cabinet

- (d) Interface cable ESU
 - 20 to 60 ma Customer-provided
 - EIA Customer-provided
 - Type 25-pin connector
 - Length6 feet
 - ESU with modem . . . 7-pin connector to mate with DAA
 - Length6 feet

| DESCRIPTION | LOW | HIGH |
|------------------|-------------|-------------|
| Binary state | 1 | 0 |
| Signal condition | mark | space |
| Control function | off | on |
| EIA voltage | -3 to -15 v | +3 to +15 v |
| Normal voltage | -12 v | +12 v |

(b) DC interface for 20 or 60 ma from an external power source. Allowed voltage range is +25 to +120 volts dc. The terminal accepts the following signals for dc interface applications:

- DC Signal lead (+) . . . P11 pin no. 11
- DC Signal lead (-) . . . P11 pin no. 9
- DC Signal ground (FDX) (+ receive line - send line) P11 pin no. 7

3.03 Set Internal Power

- (a) EIA voltages for data and control functions:

3.04 Transmitting and Receiving Margins

- (a) Transmitting - Signals from these terminals will have no more than 5 percent distortion.

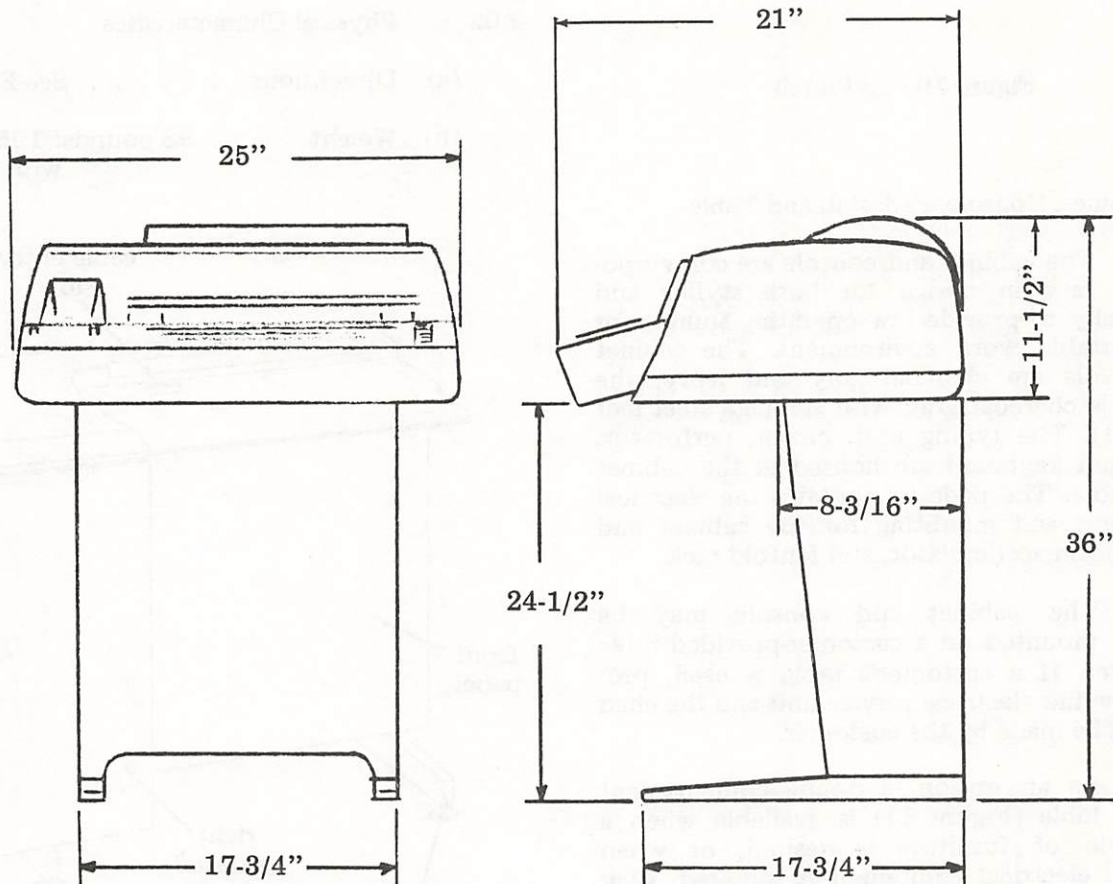

Figure 12 - 38 ASR Set Dimensions

- (b) Receiving — Will accept a signal with a maximum of 35 percent bias distortion and 33 percent end distortion.

3.05 ESU With Modem

- (a) Modulation Frequency shift
- (b) Timing Asynchronous
- (c) Code Insensitive
- (d) Turn around time (transmission to receive) Half-duplex 100 ms
Full-duplex instantaneous
- (e) Signal level 0 to -12 dBm transmit
0 to -50 dBm receive

NOTE: dBm = Decibels referenced to 1 milliwatt of power at 600 ohms impedance.

- (f) Echo suppressor disable Receipt of answering terminal's carrier, disables echo suppress
- (g) Phone line interface Manual data access arrangement 1000A, 2 leads:
DT — Data Tip
DR — Data Ring
- (h) Terminal controls . . . OFF/ALARM
ORIGINATE
FULL-DUPLEX
ECHOPLEX
LOCAL
BREAK
HERE IS
- (i) Environmental Operating temperature
40°F to 110°F
up to 95 percent max

4. INTERFACE INFORMATION

4.01 Two electrical service units are available for the standard Model 38 Set. These two ESUs provide three types of electrical interface. The interfaces associated with each ESU are an integral part of the electrical assembly. The two ESU assemblies are described in the following paragraphs and a typical mounting for an ESU is shown in Figure 13.

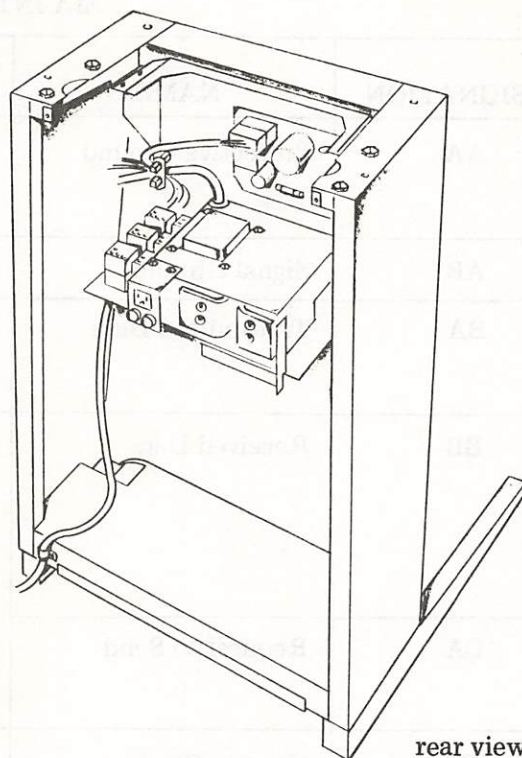

Figure 13 - ESU in Pedestal

EIA Channel Interface

4.02 One ESU provides interface signals that conform to EIA RS-232-C and are listed along with the name, purpose, and pin number of each lead in Table A. The leads which have designations beginning with "A" are ground leads. Interface leads which have designations beginning with "B" are data leads. Interface leads which have designations beginning with "C" are control leads.

4.03 The ESU for EIA channel interface also provides a current interface on either 20 or 60 ma dc. The customer has the option of strapping for either current, but the sets from the factory will be wired for 20 ma dc. Refer to the WD package accompanying the set for wiring instructions.

4.04 The EIA and current interface has a six-button key switch that mounts at the right side of the console, for the operator control and signaling, refer to Figures 14 and 15.

ESU With Modem

4.05 This electrical service unit contains a data modem that converts digital data from the set components, and converts this information to analog frequency shift audio tone

TABLE A

EIA INTERFACE LEADS

| DESIGNATION | NAME | PIN NO. | PURPOSE |
|-------------|---------------------|---------|--------------------------------------------------------------------------------------------------------------------------------------------------------------------------------------------------------------------------------------------------------------|
| AA | Protective Ground | 1 | To connect ac power service ground to equipment chassis. It is electrically isolated from signal ground. |
| AB | Signal Ground | 7 | To provide ground for all signal circuits. |
| BA | Transmitted Data | 2 | To carry set output data when the set is in the on-line mode and to remain "marking" when set is in the off-line (local) mode. |
| BB | Received Data | 3 | To present incoming data to the set when the set is in the on-line mode. <i>NOTE: If this lead is grounded at the interface, the set will act as if it were in the "marking" condition.</i> |
| CA | Request to Send | 4 | To condition local line interface unit to transmit. This lead is connected permanently on by a strap in the set. |
| CB | Clear to Send | 5 | To inform set that local data set is ready to transmit any data presented on BA lead. |
| CC | Data Set Ready | 6 | To inform the set that local data set is connected to the transmission facility. <i>NOTE: When this lead is on, it causes set motor to start running.</i> |
| CD | Data Terminal Ready | 20 | To inform data set that the set is ready to receive data messages. <i>NOTE: The set is prepared to receive when:</i> <i>(a) No alarms are present.</i> <i>(b) Set is not in "do not answer" mode.</i> <i>(c) Typing unit is on-line.</i> |

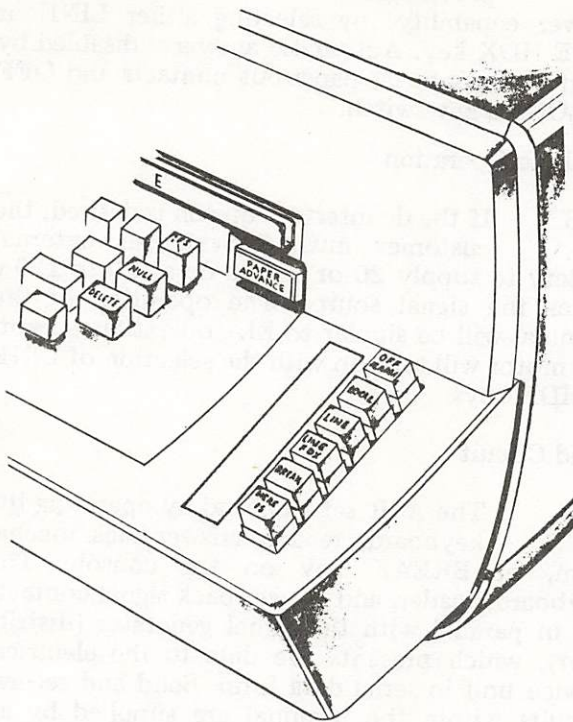

Figure 14 - Control Console for ESU Without Modem

to the Data Access Arrangement. The electrical assembly for the data modem contains a modem circuit card, logic card, and power supply which interconnect through cables and Molex connectors. The interface cable, using a Molex connector on the circuit card to interface with a private line or switched network service, must be provided by the customer.

4.06 The electrical interface is compatible with private telephone lines or data access arrangement, Bell System 1000A, 1001B, 1001D, or similar units. This ESU has the capability to provide either manual or automatic answer; both arrangements provide manual originate. Controls for the ESU with modem are shown in Figures 16 and 17. Refer to Section 574-423-100TC for the description and principles of operation of the electrical service unit.

5. OPERATION

5.01 The operation of the set is described in terms of the controls located on the console and interface leads. The ASR set may be operated locally (off-line), on-line, or simultaneously locally and on-line. Model 38 terminals may be used with the magnetic tape data terminal to obtain speeds of 1050, 1200, 2000, or 2400 baud.

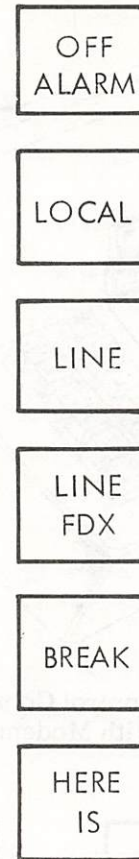

Figure 15 - Console Controls for Set Without Modem

5.02 The Model 38 ASR Set is used as computer Input-Output (I/O) machines and in the following services:

- (a) Switched Network
- (b) Selective Calling (Multipoint Private Line)
- (c) Point-to-Point Private Line

EIA Operation With 103 or 113 Type Data Sets

5.03 The terminal is conditioned for on-line half-duplex operation by depressing the LINE key. Calls can now be originated or answered in the data mode. After the call has been established by the data set, terminal motors will turn on, indicating that the set is now conditioned to send or receive data on-line.

5.04 Selection of the LINE FDX key provides full-duplex operation of the terminal similar to that in 5.03 except, data may be transmitted and received from a remote terminal simultaneously. The LINE FDX key is intended primarily for operation in a full-duplex hook-up, it can also be utilized for half-duplex operation when local monitor copy of data being sent is not required.

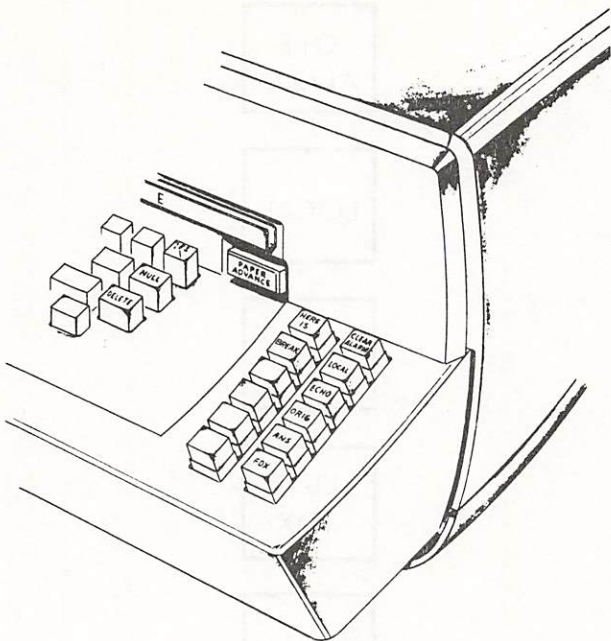

Figure 16 - Control Console for ESU With Modem

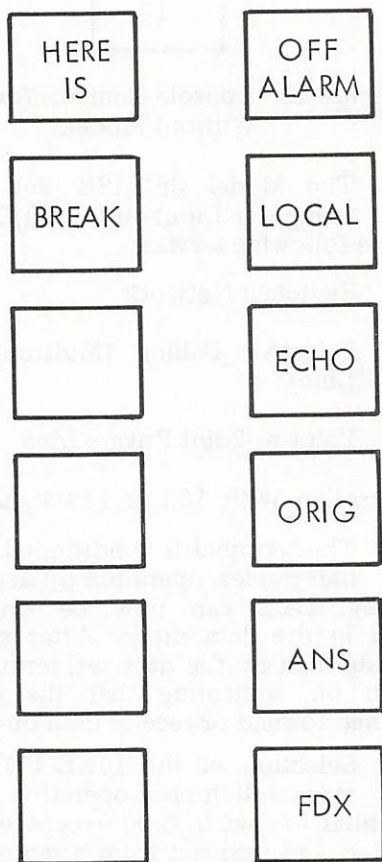

Figure 17 - Console Controls for Set With Modem

5.05 Calls may be answered automatically, providing the data set has automatic answer capability, by selecting either LINE or LINE HDX key. Automatic answer is disabled by form-feed contacts, paper-out contacts and OFF or LOCAL key switch.

DC Line Operation

5.06 If the dc interface option is desired, the customer must provide an external battery to supply 20 or 60 ma dc at 20 to 125 v dc as the signal source. The operation of the terminal will be similar to EIA operation except, the motor will turn on with the selection of LINE or HDX keys.

Send Circuit

5.07 The ASR set can send by operating the keyboard, reader, answer-back mechanism, or BREAK key on the console. The keyboard, reader, and answer-back signal contacts are in parallel with the signal generator (distributor), which presents the data to the electrical service unit in serial data form. Send and receive circuits within the terminal are supplied by an internal 24 v dc battery at 20 ma. The BREAK key is independently connected into the internal signal circuit at the electrical service unit.

5.08 Transmission over dc telegraph loop or telephone line may be accomplished by tape transmission. A prepared tape is placed into the reader. The operator depresses the LINE or LINE FDX key. After making the connection, the reader is started by momentarily moving the control lever to the start position. The printer will operate (half-duplex only) and the message will be transmitted to the distant station. As the end of tape approaches the reading gate, or if the tape becomes taut during transmission, the reader will stop by action of the tape-out tight-tape switch. Each of these conditions operate the same switch through different linkages.

5.09 A break detection circuit is optionally available to receive and recognize a "break" transmitted from a distant station. The break detect circuit will stop tape reader transmission, blind sending circuits, and light an alarm lamp. To clear the alarm condition, the operator must operate the BRK-RLS key.

Receive Circuits

5.10 The internal 20 ma signal circuit supplies a dc signal to the selector magnet driver associated with the page printer. The selector magnet driver amplifies this signal to 500 ma dc to operate the selector magnet on the page printer.

Answer-Back

5.11 The answer-back message is a fixed series of characters used to identify a station. It consists of a commutator disc and brush-type of signal generator and a coded drum with sensing contacts to determine the message. The answer-back drum has 21 positions for characters. This can be reduced to three sections of 7 positions by removing tines on the drum. The output can be blinded on a given character position by one of the sensing contacts if the associated tine on the drum is not removed. The drum is coded to send the required message by removal of the appropriate tines on the drum. Thus any fixed message from 1 to 20 characters can be sent by the answer-back.

NOTE: The first character position must always be blinded for timing reasons.

5.12 The answer-back mechanism is tripped by a magnet pulsed from external contact function box contacts or the HERE IS key. Closure of any of these contacts places ground on the answer-back lead to energize the answer-back clutch trip magnet.

5.13 During a call the answer-back mechanism can be tripped manually (HERE IS key) or by a code combination (ENQ). The ENQ operates at both sending and receiving stations, but only the receiving station answer-back is tripped. The sending station answer-back is not tripped because the function box is blocked whenever the distributor is tripped.

Disconnecting a Call

5.14 A call will normally be terminated by the EOT code combination which provides fast disconnect without introducing hit characters. This is accomplished by the electrical service unit in response to EOT contact opening in the typing unit function box.

5.15 Alternately to clear a connection, the OFF or LOCAL locking key is operated. This triggers the clearing sequence in the electrical service unit.

Local Operation

5.16 The local operation provides off-line operation of the set. The operator selects the local mode by depressing the LOCAL locking key. The LOCAL key lights the local lamp and operates the motor control relay which in turn makes the motor run. The ESU connects the sending circuit to the receiving circuit enabling the keyboard and answer-back to send to the page printer.

5.17 Should an outside call attempt to connect with the printer while in the local mode, the call may be answered by the operator by depressing the LINE key. If no interruption is desired, the set may be placed into the off condition by depressing the OFF locking key.

5.18 The set can be conditioned to prepare tape locally by depressing the LOCAL key and operating the perforator ON switch. Every time the keyboard is operated the printer will print the message while the perforator will prepare tape. If an error occurs the switch may be moved to the backspace position. This will back the tape by one character at a time. After the tape has been prepared, a series of rubout (delete) characters may be used to clear the last character desired from the punch block.

Off Key/Paper Handling

5.19 The OFF key prevents the automatic answering of incoming calls. It can be used for normal servicing of the terminal or to place the terminal in inactive status during idle periods. The OFF key may be used to facilitate paper insertion because it insures that the set will not automatically answer while the paper is being inserted into the machine. The paper alarm is indicated by a lamp located on the OFF key. If a low-paper alarm is given during a call the operator has the option of completing the call before changing paper or interrupting the call. If she chooses to interrupt the call she must stop transmission at some convenient point and notify the distant station of the problem. Momentarily depress the CONTROL key and the END OF TRANSMISSION key simultaneously, which will clear the connection.

5.20 On units equipped for handling sprocket forms, there is a paper-out contact. Should the operator ignore the low-paper alarm, or should the present message be too long, the contact will close when the last form passes by and will automatically cause a disconnect.

Set Controls and Functions

5.21 The description of set controls are outlined in Tables A and B. Refer to 5.12, 5.13, and 5.14 for information on HERE IS, ENQ, and EOT. Two-color printing is activated by using "ESC" "3" for red ribbon and "ESC" "4" for black ribbon.

5.22 The BELL responds to the sending and receiving station when the function is transmitted. The Paper Out Alarm key on sprocket feed unit illuminates when the last form has been fed into the platen; when this occurs, if the unit is on-line, the call will immediately terminate.

TABLE B
CONTROLS DESCRIPTION

| CONTROL | DESCRIPTION | USE |
|---------------|-----------------------------------------------------------------------------------------------------------------------------------------------------------------|----------------------------------------------------------------------------------------------------------------------------------------------|
| PAPER ADVANCE | When this key is held depressed, the typing unit feeds paper until key is released. | Operator controls paper feed with no effect on line signals. |
| LOCAL RETURN | When this key is momentarily depressed, causes the carriage to return for starting a new line. | Operator activates carriage return with no effect on line signals. |
| OFF ALARM | Depressing key — motor off and set is out-of-service. Illuminated red for alarm. | Set off-line. Paper handling and low-paper or paper-out condition. |
| LOCAL | Motor on — set operable but cannot send or receive. | Set off-line. Punching tape, testing. |
| ECHO | Depressing keys simultaneously with the remote station for sending or receiving (FDX only). The transmitted data is echoed back and printed on the typing unit. | Set on-line. Error check and detection used with either ORIG or ANS. |
| ORIG | Originate — turns motor on. When lighted, indicates presence of receive carrier. | Set on-line — conditions set for call origination and after establishment of a call. |
| ANS | Answer — manual or automatic response to a sending station. Depressing key causes answer-back to trip. | Set on-line — conditions set to answer incoming calls. Call will disconnect in 4 to 6 seconds if not answered. |
| FDX | When depressed (lighted) set is in full-duplex mode. When key is not selected, the set is in half-duplex. | Set on-line — permits simultaneous sending and receiving. Hard copy and punch tape of received data. |
| HERE IS | When depressed it operates a stored series of up to 20 characters to be transmitted over the line. | Set on-line — set identification is sent to the remote terminal. |
| BREAK | When depressed, places a spacing condition on the signal line. An alarm condition to stop reader, blind sending circuit. | On-line operation after a call has been established — sends and recognizes a break signal in both LINE and FDX modes. Lights the alarm lamp. |
| LINE | Motors on — full capability for HDX. | On-line operation conditions the set to receive data. |
| LINE FDX | Motors on — full capability for HDX or FDX. | On-line operation conditions the set to send and receive data. |

READER

5.23 The Model 38 paper tape reader can be operated in the manual or automatic modes. Sets are shipped with the reader in the manual mode. By removing a wire strap on the reader circuit, refer to the Wiring Diagram Package (WDP) furnished with the set, the automatic feature can be activated.

Manual Operation

5.24 Controls for the paper tape reader are located on the left side of the unit, refer to Figure 18; Table C calls out the controls and describes the operation of each position of the control lever.

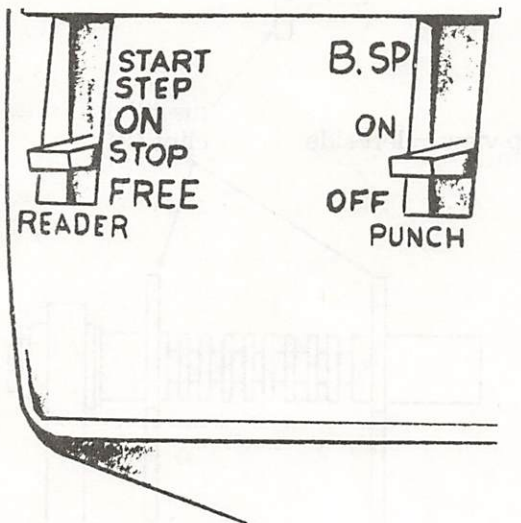

left side of console

Figure 18 - 38 Reader and Punch Controls

Automatic Operation

5.25 When the reader is in the automatic mode, control can be accomplished by the reader controls on the console or through the keyboard. In on-line operation, sending or receiving can be initiated and controlled from a remote station. In Selective Calling Systems the reader can be controlled from a line controller-computer that polls each of the stations in the system according to a predetermined program.

5.26 The reader in the automatic mode responds to the receipt of ASCII control codes. To operate the reader from external control, the bat handle switch must be positioned to ON and a coded tape must be in the reader. The following control codes cover the operations of the reader from the keyboard or another input device.

- DC1 — Turns the reader on.
- DC3 — Turns the reader off.
- ENQ — Stops reader and calls in answer-back. To automatically start the reader after ENQ; the last coded answer-back character must be a DC1.
- EOT — Turns off reader and the station.

5.27 The reader will stop in response to a Form Feed (FF) code. After the completion of the form-feed operation the reader will start to process the tape when the next character is received. For the exception of ASCII designated information separators, two delete characters must follow each control character in the paper tape.

5.28 The tight-tape and tape-out switches are two safety features on the reader. The tight-tape switch operates when the paper tape

TABLE C

MANUAL READER CONTROLS

| CONTROL | OPERATION |
|---------|------------------------------------------------------------------------------------------------------------|
| START | Moving the control lever switch to this position, starts the reader. |
| STEP | Causes the reader to step for each movement of the bat handle switch; allows for single character reading. |
| ON | Spring loaded control lever returns from the START position to ON which continues reader operation. |
| STOP | Reader is inoperative in this position. |
| FREE | Enables the paper tape to be manually pulled through the reader for positioning. |

becomes tight or tangled by turning off the reader and prevents the tape from tearing. The tape-out switch operates when the end of the tape is sensed, and automatically turns off the reader before the last four characters on the tape have been read.

PUNCH

5.29 The tape punch is shipped programmed for manual operation. The tape punch has the facility for automatic operation by removing two clips, refer to Figure 19. The controls for manual operation are listed in Table D.

5.30 The automatic operation of the punch responds to the receipt of ASCII control codes. The local keyboard or a remote station sending a DC2 code will turn the punch on. The sending station turns the receiving station's punch off at the end of the message by using the DC4 control code.

5.31 In preparing tapes for subsequent transmission, all control codes (except information separators) should be followed by two DELETE characters. These characters allow the terminal to perform functions before additional data is transmitted.

5.32 Error correction is accomplished by positioning the tape so that a character to be blocked out is over the punch block. The DELETE key on the keyboard is typed over the error followed by typing the correct character. When the reader senses delete characters no punching, printing, or spacing occurs. This feature allows the page copy to maintain the correct format.

6. REFERENCES

6.01 The publications associated with the Model 38 equipment are subdivided into the following four manuals: Operator's, Installation and Servicing, Maintenance, and Motor Manuals. These manuals provide general and specific technical information for this equipment. The Maintenance Manual is divided into three volumes and each volume is made up of a group of appropriate, independent, sections. Volume 1 contains sections for description, troubleshooting, lubrication, and disassembly and reassembly. Volume 2 provides the adjustments and Volume 3 includes the part sections. The following publications pertain to the ASR set.

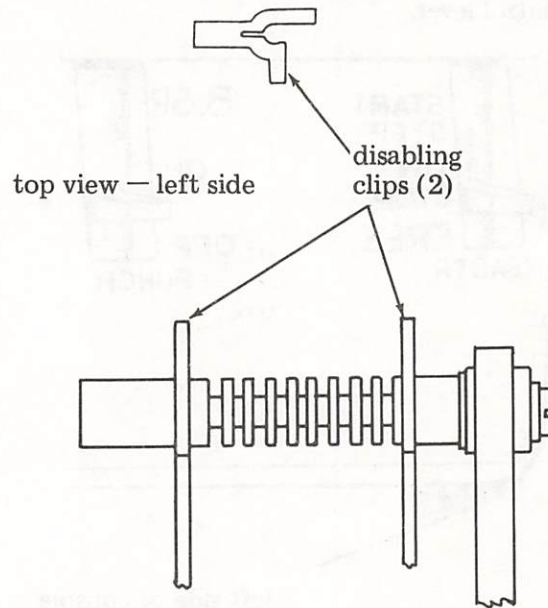

Figure 19 - 38 Perforator Lever Post

TABLE D

MANUAL PUNCH CONTROLS

| CONTROL | OPERATION |
|---------|------------------------------------------------------------------------------------------------------------------------------------------------------------------------|
| B.SP. | Primarily used for tape correction. Each time the control lever switch (Figure 18) is moved to this position, the tape moves in reverse direction one character space. |
| ON | Punch operates and permits characters received by the printer to be punched on the tape. |
| OFF | Punch inactive and prohibits punching the tape. |

| <u>TITLE</u> | <u>NUMBER</u> |
|-----------------------------------|---------------|
| Installation and Servicing Manual | 341 |
| Operator's Manual | 342 |
| ASR Maintenance Manual | 343 |

Volume 1

| | |
|---------------------------------------|---------------|
| Description and Operation | 574-400-100TC |
| Troubleshooting | 574-400-300TC |
| Removal and Replacement of Components | 574-400-700TC |

Keyboard

| | |
|----------------------------|---------------|
| Description and Operation | 574-421-100TC |
| Lubrication | 574-421-701TC |
| Disassembly and Reassembly | 574-421-702TC |

Printer

| | |
|----------------------------|---------------|
| Description and Operation | 574-422-100TC |
| Lubrication | 574-422-701TC |
| Disassembly and Reassembly | 574-422-702TC |

Electrical Service Unit

| | |
|----------------------------|---------------|
| Description and Operation | 574-423-100TC |
| Disassembly and Reassembly | 574-423-702TC |

Reader

| | |
|----------------------------|---------------|
| Description and Operation | 574-424-100TC |
| Lubrication | 574-424-701TC |
| Disassembly and Reassembly | 574-424-702TC |

Punch

| | |
|----------------------------|---------------|
| Description and Operation | 574-425-100TC |
| Lubrication | 574-425-701TC |
| Disassembly and Reassembly | 574-425-702TC |

Cover

| | |
|----------------------------|---------------|
| Lubrication | 574-426-701TC |
| Disassembly and Reassembly | 574-426-702TC |

| <u>TITLE</u> | <u>NUMBER</u> |
|--------------------|---------------|
| <u>Volume 2</u> | |
| <u>Adjustments</u> | |
| Keyboard | 574-421-700TC |
| Printer | 574-422-700TC |
| Reader | 574-424-700TC |
| Punch | 574-425-700TC |
| Cover | 574-426-700TC |

Volume 3

Parts

| | |
|-------------------------|---------------|
| Keyboard | 574-421-800TC |
| Typing Unit | 574-422-800TC |
| Electrical Service Unit | 574-423-800TC |
| Reader | 574-424-800TC |
| Tape Punch | 574-425-800TC |
| Cover and Table | 574-426-800TC |

Motor Bulletin 295B

7. APL SETS

7.01 The APL (A Programming Language) set is equipped with special symbols which allow the customer to use it in APL applications. Upper case letters of the alphabet and numerics are also generated. All the symbols generated by this set are shown in Figure 20. The APL set does not generate lower case letters of the alphabet.

7.02 The APL Sets are 60 Hz, ASR or KSR terminals. Interface is the same as for the standard Model 38 sets: DC neutral current, EIA, or modem. The APL Sets are available as wide platen (14-7/8 inch) sprocket feed terminals or 8-1/2 friction feed. A Modification to reduce the 14-7/8 inch sprocket platen to 8-1/2 inch is also available. Refer to the Model 38 Catalog.

7.03 The APL characters generated by this set are shown in Figure 21. The code assignments are shown in Figure 22. APL overstrike characters are achieved by generating the primary symbol, backspacing, and then generating the overstrike symbol. The overstrike symbols are shown in Figure 23.

7.04 In order to backspace, the 38 APL Set is equipped with a backspace mechanism. A detailed description of this mechanism may be found in Section 574-422-100TC.

7.05 The 8th bit always marking option is not available on the APL Sets.

| APL CHARACTER DESIGNATION | | | |
|---------------------------|--------------------------|------------|---------------------------|
| APL SYMBOL | DESCRIPTION | APL SYMBOL | DESCRIPTION |
| •• | UMLAUT OR DIAERESIS | α | ALPHA |
| - | NEGATIVE | ⌈ | CEILING OR MAXIMUM |
| < | LESS THAN | ⌋ | FLOOR OR MINIMUM |
| ≤ | LESS THAN OR EQUAL TO | — | UNDERLINE |
| = | EQUAL | ∇ | DEL |
| ≥ | GREATER THAN OR EQUAL TO | Δ | DELTA |
| > | GREATER THAN | ° | DEGREE (SMALL CIRCLE) |
| ≠ | NOT EQUAL | ' | QUOTE |
| ∨ | OR | □ | QUAD |
| ∧ | AND | (| PARENTHESIS |
| - | MINUS |) | PARENTHESIS |
| ÷ | DIVISION | [| BRACKET |
| + | PLUS |] | BRACKET |
| x | TIMES | ⊂ | UNNAMED |
| ? | ROLL | ⊃ | UNNAMED |
| ω | OMEGA | ∩ | UNNAMED |
| ε | ELEMENT | ∪ | UNNAMED |
| ρ | RHO | ⊥ | DECODE |
| ~ | NOT | ⊤ | ENCODE |
| ↑ | TAKE | | ABSOLUTE VALUE OR RESIDUE |
| ↓ | DROP | ; | SEMICOLON |
| ⌊ | IOTA | , | CATENATION |
| ∘ | PI TIMES | : | COLON |
| * | EXPONENT | . | DECIMAL |
| → | BRANCH | \ | LEFT SLASH |
| ← | ASSIGN | / | RIGHT SLASH |
| ⊢ | UNNAMED | | |
| ⊣ | UNNAMED | | |

Figure 21 - APL Characters

| Bits | | | | | 0 0 0 | 0 0 1 | 0 1 0 | 0 1 1 | 1 0 0 | 1 0 1 | 1 1 0 | 1 1 1 | | | | |
|------|----|----|----|----|-------|-------|--------|-------|-------|-------|-------|-------|---|---|---|-----|
| b7 | b6 | b5 | b4 | b3 | b2 | b1 | COLUMN | ROW | 0 | 1 | 2 | 3 | 4 | 5 | 6 | 7 |
| 0 | 0 | 0 | 0 | 0 | 0 | 0 | 0 | 0 | NUL | DLE | SP | 0 | ← | P | → | * |
| 0 | 0 | 0 | 1 | 1 | 1 | 1 | 1 | 1 | SOH | DC1 | •• | 1 | A | Q | α | ? |
| 0 | 0 | 1 | 0 | 1 | 1 | 1 | 2 | 2 | STX | DC2 | — | 2 | B | R | ⊥ | ρ |
| 0 | 0 | 1 | 1 | 1 | 1 | 1 | 3 | 3 | ETX | DC3 | < | 3 | C | S | ∩ | τ |
| 0 | 1 | 0 | 0 | 1 | 1 | 1 | 4 | 4 | EOT | DC4 | ≤ | 4 | D | T | ℓ | ~ |
| 0 | 1 | 0 | 1 | 1 | 1 | 1 | 5 | 5 | ENQ | NAK | = | 5 | E | U | ε | ↓ |
| 0 | 1 | 1 | 0 | 1 | 1 | 1 | 6 | 6 | ACK | SYN | ≥ | 6 | F | V | — | U |
| 0 | 1 | 1 | 1 | 1 | 1 | 1 | 7 | 7 | BEL | ETB | > | 7 | G | W | ∇ | ω |
| 1 | 0 | 0 | 0 | 1 | 1 | 1 | 8 | 8 | BS | CAN | ≠ | 8 | H | X | Δ | ∫ |
| 1 | 0 | 0 | 1 | 1 | 1 | 1 | 9 | 9 | HT | EM | √ | 9 | I | Y | ℓ | ↑ |
| 1 | 0 | 1 | 0 | 1 | 1 | 1 | 10 | 10 | LF | SUB |) |] | J | Z | ο | ∫ |
| 1 | 0 | 1 | 1 | 1 | 1 | 1 | 11 | 11 | VT | ESC | (| [| K | } | ι | } |
| 1 | 1 | 0 | 0 | 1 | 1 | 1 | 12 | 12 | FF | FS | , | ; | L | ⊥ | □ | ⊥ |
| 1 | 1 | 0 | 1 | 1 | 1 | 1 | 13 | 13 | CR | GS | + | — | M | X | | ÷ |
| 1 | 1 | 1 | 0 | 1 | 1 | 1 | 14 | 14 | SO | RS | . | : | N | ◇ | T | § |
| 1 | 1 | 1 | 1 | 1 | 1 | 1 | 15 | 15 | SI | US | / | \ | O | ∧ | ο | DEL |

Characters in Shaded Areas Conform to 1968 ASCII

Figure 22 - APL Code Assignments

| APL OVERSTRIKE CHARACTER GENERATION | | | | |
|-------------------------------------|------------------------------------|----------------|-------------------------------------------|--------------------|
| COMPLETED SYMBOL | DESCRIPTION | PRIMARY SYMBOL | | OVER-STRIKE SYMBOL |
| ⊗ | LOGARITHIM | ο | B A C K S P A C E | * |
| φ | REVERSAL OR ROTATE | ο | | |
| ⊙ | TRANSPOSE | ο | | \ |
| Δ | GRADE UP | Δ | | |
| ∇ | GRADE DOWN | ∇ | | |
| ⊞ | COMMENT OR LAMP | ∩ | | ο |
| ⊞ | QUOTE QUAD | ' | | □ |
| ! | FACTORIAL COMBINATION | ! | | . |
| ∧ | NAND | ∧ | | ~ |
| ∨ | NOR | ∨ | | ~ |
| ∇ | DEL TILDE | ∇ | | ~ |
| ⊞ | I BEAM | ⊞ | | ⊞ |
| ⊞ | UNNAMED | ⊞ | | ⊞ |
| ⊞ | "ANY ST'D. SCALAR DYADIC OPERATOR" | ο | | ο |

Figure 23 - APL Overstrike Symbols

8. OPTIONAL FEATURES

- 188800 Modification Kit — Provides Model 38 wide platen sprocket feed printer with facilities to use 8-1/2 inch wide friction paper.

Description

8.01 The 188800 modification kit allows the 14-7/8 inch wide platen sprocket feed Model 38 terminal to use 8-1/2 inch narrow platen friction feed paper. The modification is not permanent. The customer may use either the 14-7/8 inch paper or the 8-1/2 inch paper. A selection lever mounted at the right of the platen is marked "N" and "W." In the "N" (narrow) position, 8-1/2 inch paper can be used; in the "W" (wide) position, 14-7/8 inch paper can be used.

8.02 When the 8-1/2 inch paper is used, the margin bell operates after the 66th character and the automatic carriage return-line feed operates after the 72nd character. When the 14-7/8 inch paper is used, the margin bell operates at approximately the 125th character and the automatic carriage return-line feed operates after the 132nd character.

NOTE: Automatic carriage return-line feed will occur as described only if the option has been installed, otherwise carriage return and line feed will take place as separate functions.

There is a minor variation in the left margins with this modification. The margin for the wide paper is approximately 1/2 inch. The margin for the narrow paper is from 0.125 inch to 0.364 inch.

8.03 Automatic Carriage Return-Line Feed

Narrow Platen — 8-1/2 inch paper: As the carriage approaches the 66th character, the carriage engages the actuating lever (Figure 24) and moves it to the right an amount greater than for the margin bell. This causes the automatic codebar to be moved to the right an equal amount. The carriage return and line feed function levers move up affecting carriage return and line feed.

Wide Platen — 14-7/8 inch paper: In the wide platen mode the actuating lever is pivoted downward, allowing the carriage to pass over it without engaging it. As the carriage approaches the right margin, it engages the automatic codebar and moves it to the right. The carriage return and line feed function levers then move up affecting both functions.

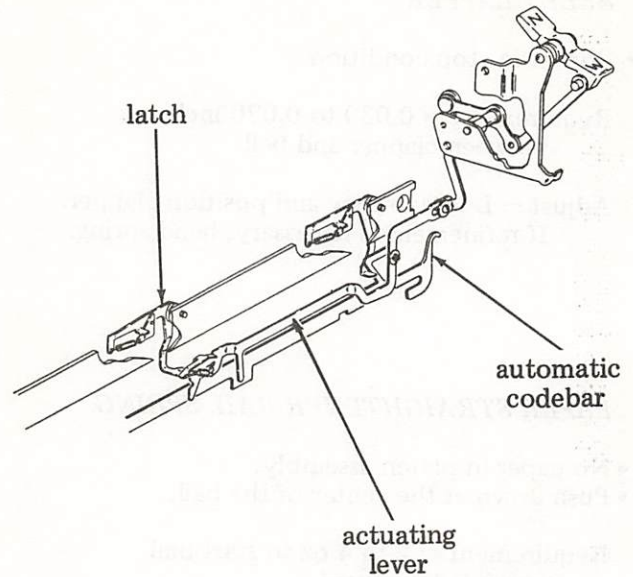

left front view

Figure 24 - Automatic Carriage Return-Line Feed and Margin Bell

8.04 Margin Bell

Narrow Platen — 8-1/2 inch paper: As the carriage moves to the right it depresses a latch. Depressing the latch causes the actuating lever to move to the right. This causes the automatic codebar to move to the right slightly. The margin bell function lever rises up and latches its pawl. During the middle portion of the function cycle, the function lever moves the pawl down. When the stripper bail strips the pawl late in the function cycle, the pawl moves up and causes the clapper mounted on the wire spring to snap and ring the bell.

Wide Platen — 14-7/8 inch paper: Margin bell, when in the wide paper mode, is similar to narrow paper. A similar mechanism is present at the far right of the carriage rail which causes the automatic codebar to move to the right slightly, allowing the margin bell function lever to move up and latch its pawl. During the middle portion of the function cycle, the function lever moves the pawl down. When the stripper bail strips the pawl late in the function cycle, the pawl moves up and causes the clapper mounted on the wire spring to snap and ring the bell.

Adjustments

BELL CLAPPER

- Printer in stop condition.

Requirement — 0.030 to 0.070 inch between clapper and bell.

Adjust — Loosen screw and position clapper.
If refinement is necessary, bend spring.

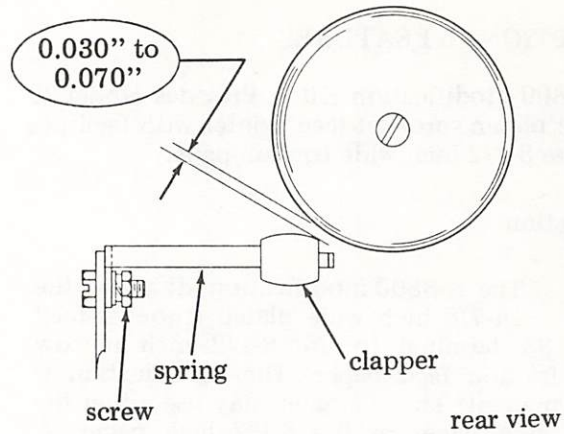

PAPER STRAIGHTENER BAIL SPRING

- No paper in platen assembly.
- Push down at the center of the bail.

Requirement — 2 to 4 oz to start bail moving downward.

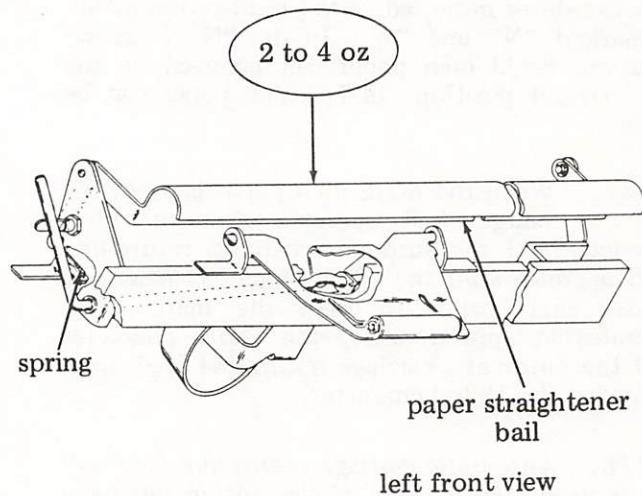

PRESSURE PLATE ENDPLAY

- Bias pressure plate against the right bracket.

Requirement — Some to 0.062 inch between left bracket and the flat surface of the pressure plate.

Adjust — Loosen mounting screws on left or right bracket.
Position left bracket.
Tighten mounting screws.

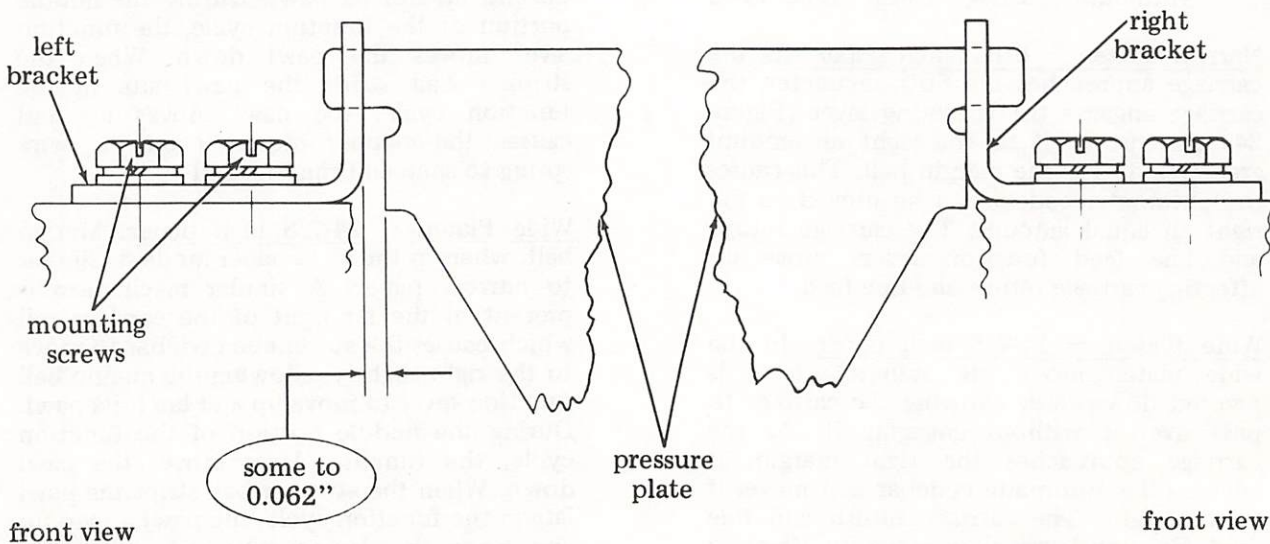

PRESSURE ROLLER CLEARANCE

- Tension roller rod in latched position.
- Move carriage to a position where the carriage is nearest the roller or plate.

Requirement — Some to 0.047 inch between carriage and plate.

Adjust — Loosen nut on lever assembly.
Move assembly up or down.
Tighten nut.

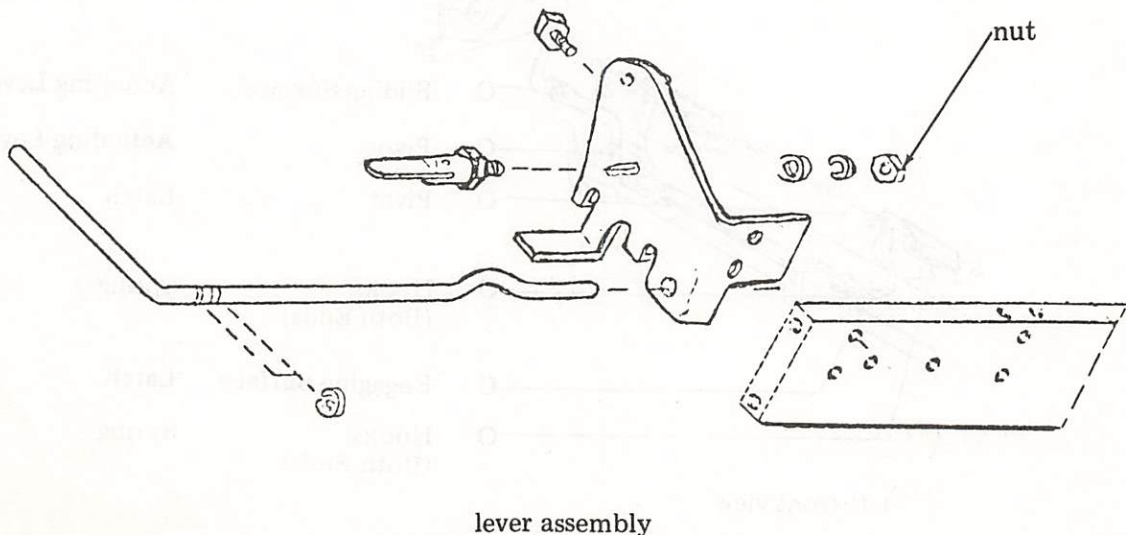
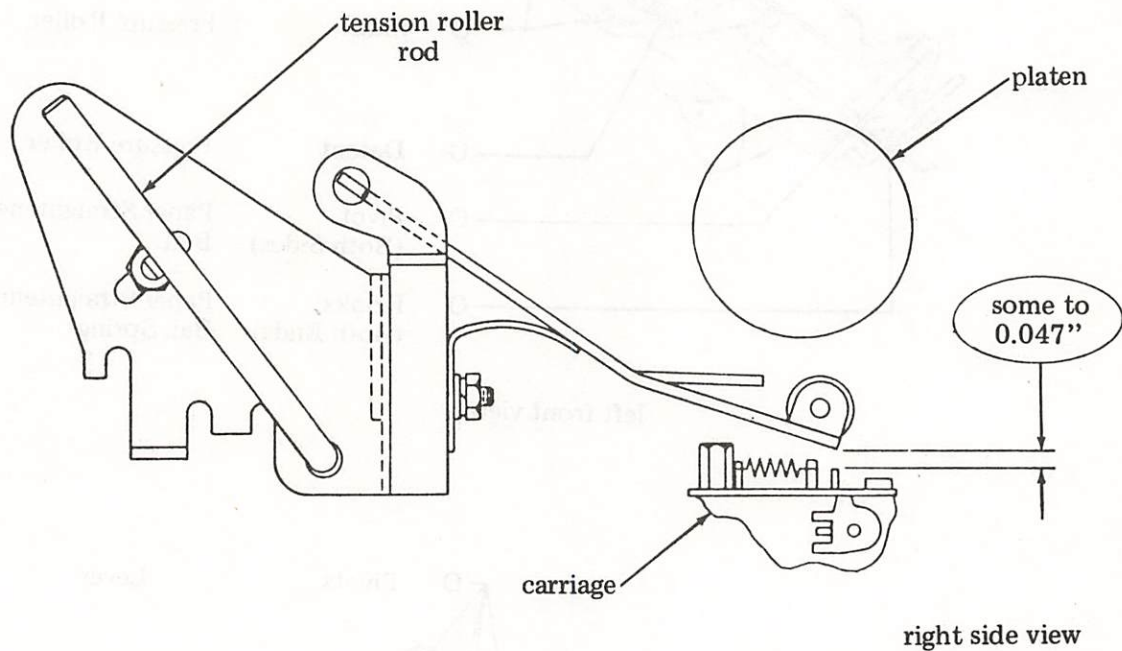

left front view

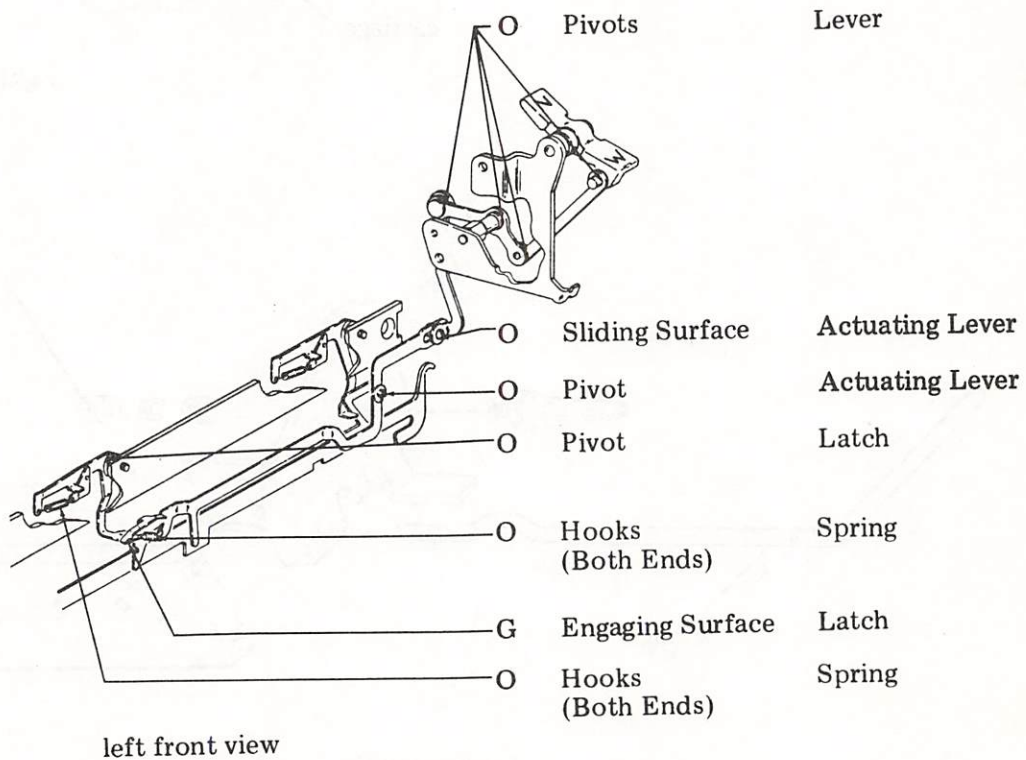
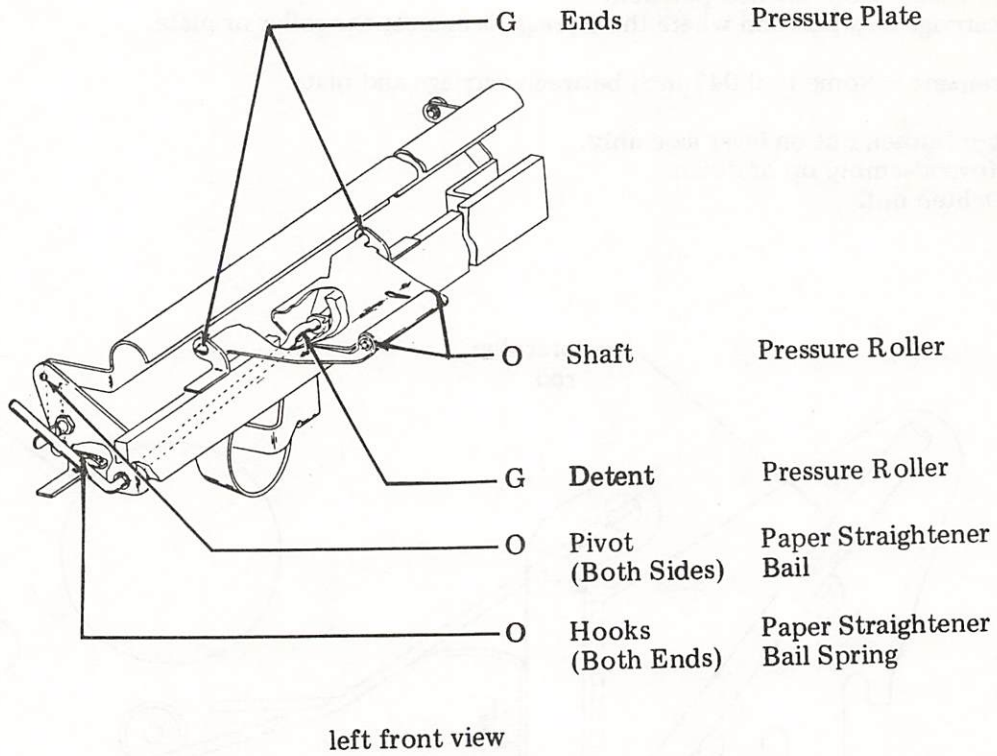

Disassembly and Reassembly

- Remove paper trough by sliding it upward.

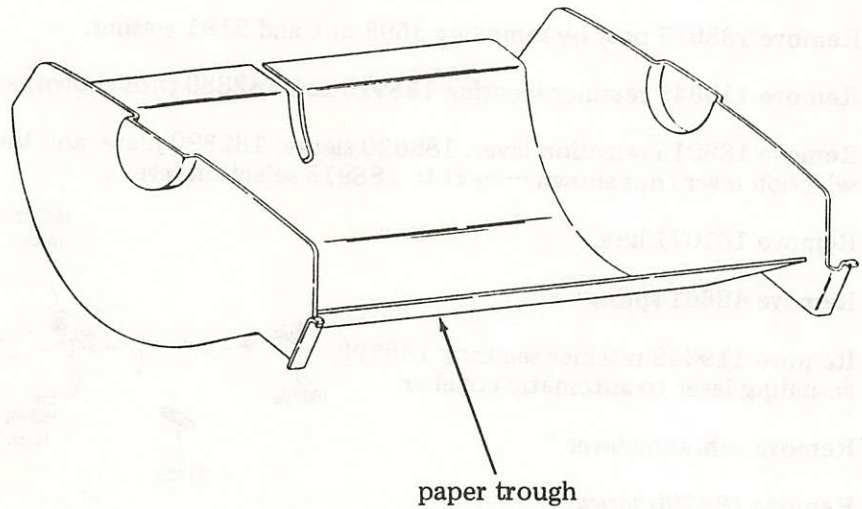

- Remove coverplate:

1. Remove 180798 screw from 188981 bracket supporting coverplate.
2. Remove 181241 screw from top of coverplate.
3. Remove two 181245 screws securing coverplate to 188911 bracket.

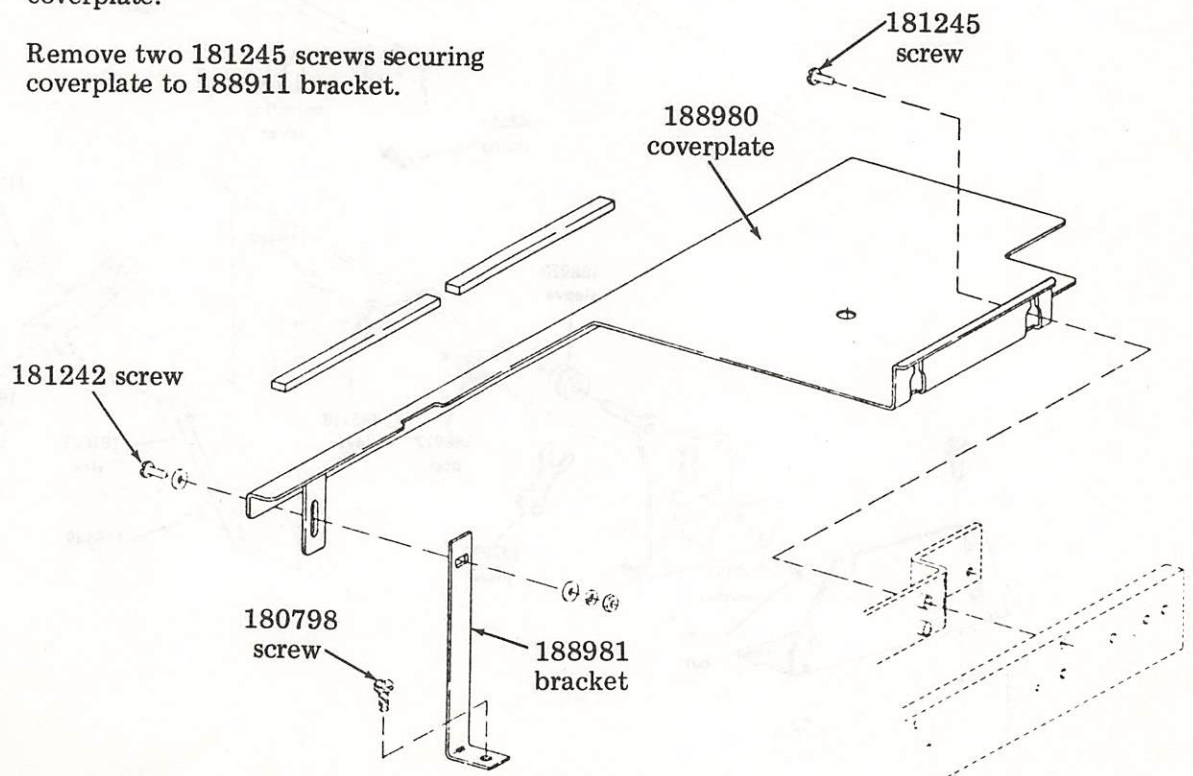

- Remove 119648 retainer holding 188919 lever in elongated slot of actuating lever.
- Remove 119649 retainer securing 188919 lever to post of 188918 lever. Remove 188919 lever.
- Remove 119649 retainer holding 181071 link to short extension of 188918 lever.
- Remove 119649 retainer and remove 188918 lever from post.
- Remove 188917 post by removing 3598 nut and 2191 washer.
- Remove 119649 retainer securing 188915 and 182889 (not shown) selection levers to post.
- Remove 188915 selection lever, 188920 sleeve, 182890 plate, and the 182889 single-double line feed selection lever (not shown — next to 188915 selection lever).
- Remove 181071 link.
- Remove 42661 spring.
- Remove 119648 retainer securing 188793 actuating lever to automatic codebar.
- Remove actuating lever.
- Remove 188796 screw.
- Remove 188792 latch.
- Remove 185968 latch and spring.

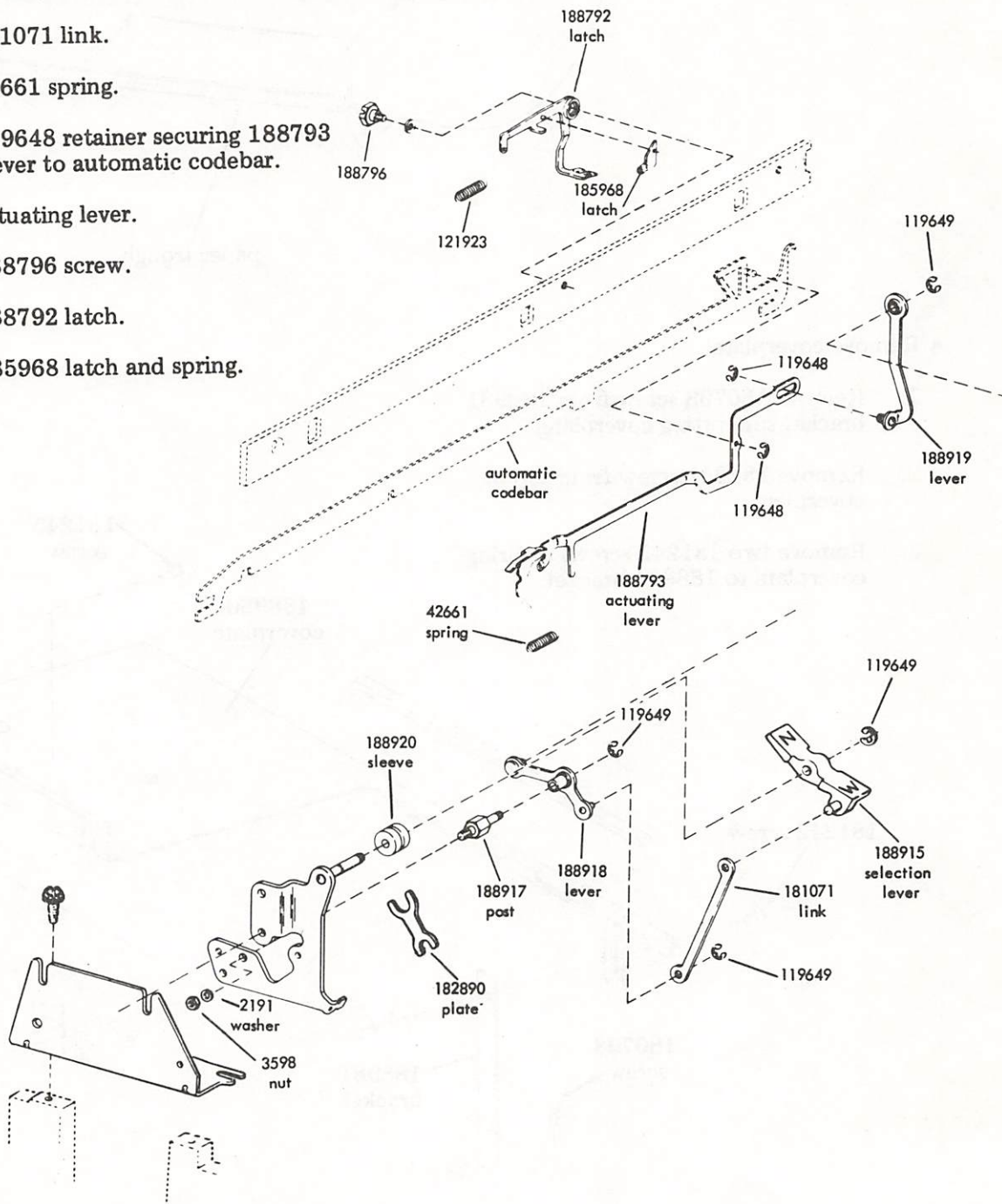

● 188944 Modification Kit — Provides Model 38 with on-line backspace.

NOTE: The backspace mechanism is a standard feature on APL (A Programming Language) sets.

Description

8.05 The backspace mechanism (Figure 25) achieves backspace by moving the feed pawl and check pawl away from the ratchet. The entire backspace function is accomplished in two parts: half a character backspaced during the first part of the printer cycle, and half in the second part of the printer cycle.

8.06 When the backspace function is received, the feed pawl and check pawl are completely disengaged from the ratchet, allowing the carriage to move to the left half a character, after which the backspace pawl engages the ratchet. As the printer completes its cycle, the backspace pawl is moved away from the ratchet and the carriage moves to the left the other half character.

8.07 When the backspace code combination is received, the backspace function lever rises and picks up its pawl which is then driven downward. This action of the function pawl is transferred to an actuating lever by means of an extension on the backspace function pawl. As this actuating lever moves downward it rotates the carriage return lever through the backspace and carriage return bails and the carriage return link. This movement of the carriage return lever is sufficient to free the feed pawl and check pawls from the spacing ratchet, but not enough movement is imparted to latch up the carriage return function.

8.08 As the backspace function pawl approaches its lowest point of travel, the pawl is stripped off by the stripper bail. This stripping action causes the feed pawl and check pawl to return to the spacing ratchet.

8.09 During a carriage return function, the backspace pawl is held away from the spacing ratchet so that should a carriage return-backspace sequence be sent, the printer does not malfunction.

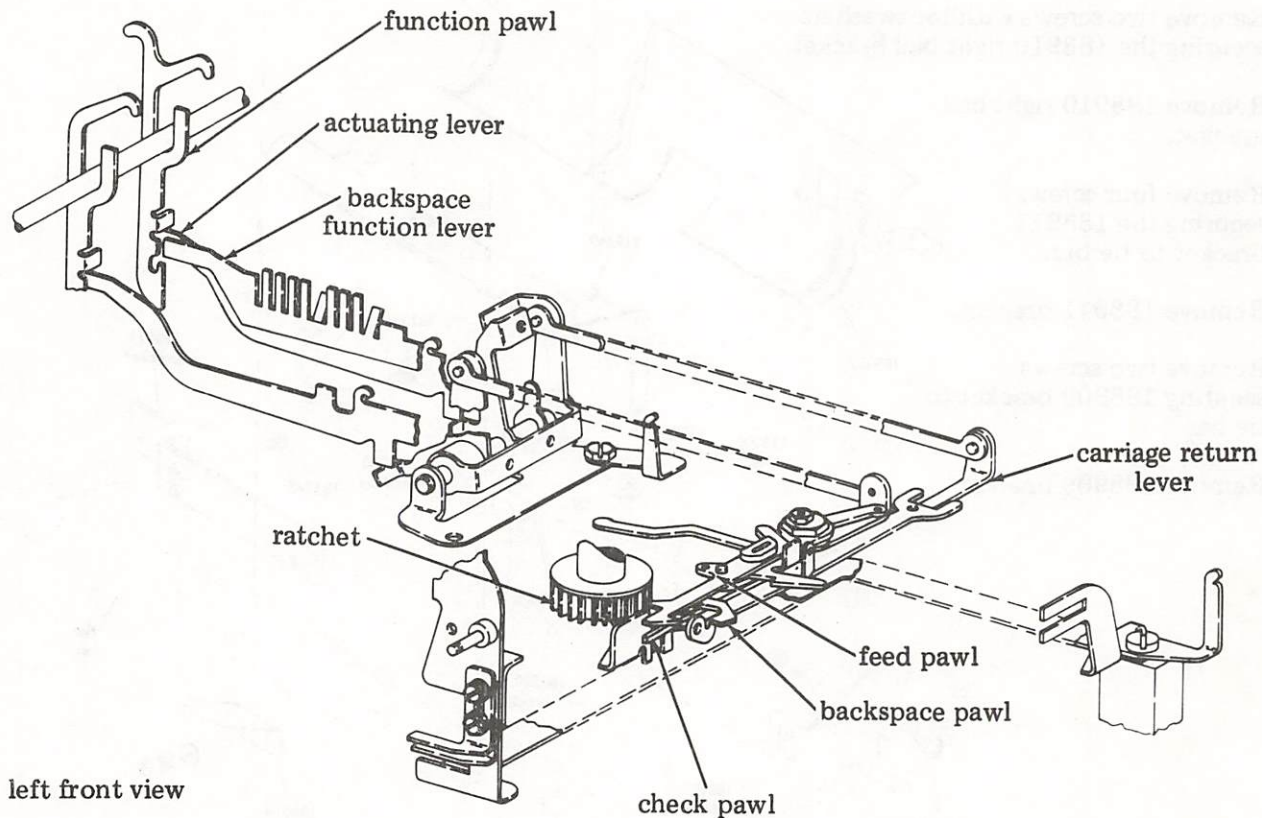
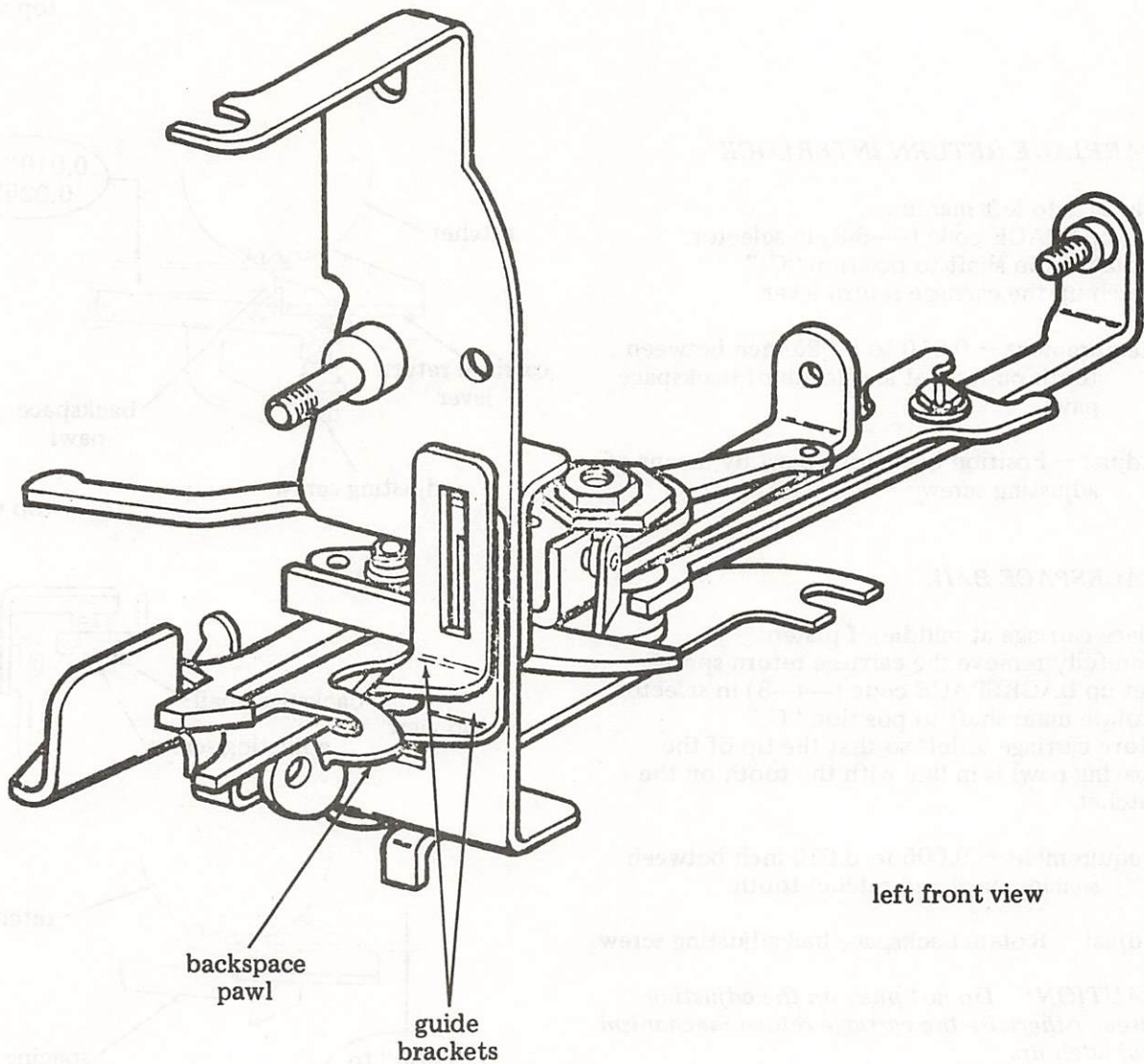

Figure 25 - Backspace Mechanism

Adjustments

NOTE 1: Before performing the backspace adjustments, position both guide brackets so that the backspace pawl does not bind and there is not too much play in it. Tighten the two guide bracket mounting screws.

NOTE 2: Sets which have been field modified with the 188944 modification kit, may require that the clearance between the function levers in slots "D" and "5" and the function lever retainer be increased to prevent interference (does not apply to sets modified at the factory).



BACKSPACE PAWL

- Printer in stop condition.
- Move carriage one or two spaces from left margin.
- Feed pawl resting against ratchet.

Requirement — The front edge of the feed pawl should line up with the groove on the backspace pawl (view requirement from above the printer).

Adjust — Position backspace pawl by means of adjusting screw.

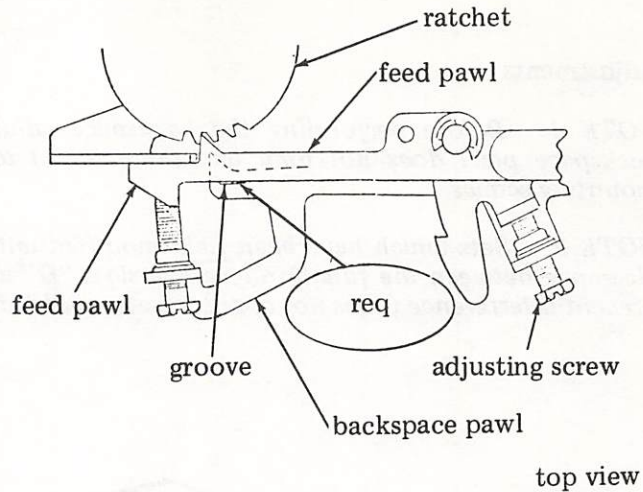

CARRIAGE RETURN INTERLOCK

- Carriage to left margin.
- Set up SPACE code (----6-8) in selector.
- Rotate main shaft to position "C."
- Latch up the carriage return lever.

Requirement — 0.010 to 0.025 inch between tooth on ratchet and tooth of backspace pawl.

Adjust — Position backspace pawl by means of adjusting screw.

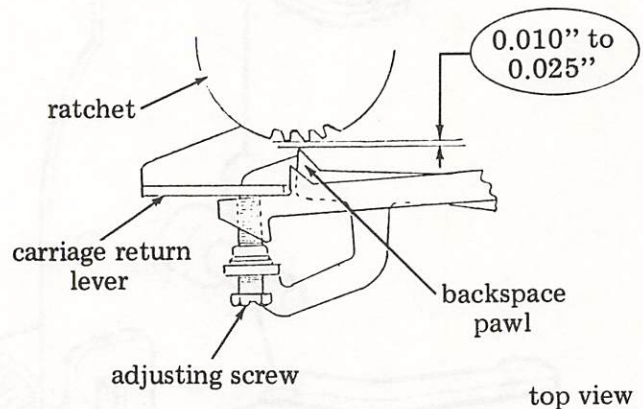

BACKSPACE BAIL

- Place carriage at middle of platen.
- Carefully remove the carriage return spring.
- Set up BACKSPACE code (---4---8) in selector.
- Rotate main shaft to position "C."
- Move carriage to left so that the tip of the spacing pawl is in line with the tooth on the ratchet.

Requirement — 0.005 to 0.010 inch between spacing pawl and ratchet tooth.

Adjust — Rotate backspace bail adjusting screw.

CAUTION: Do not push on the adjusting screw, otherwise the carriage return mechanism will latch up.

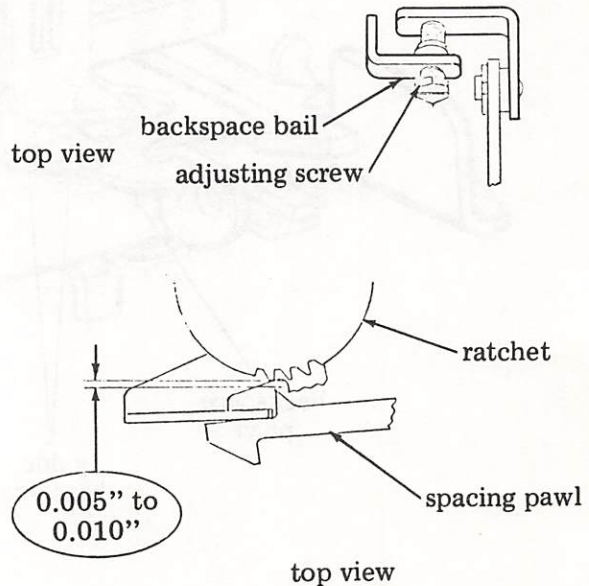

FEED PAWL TRAVEL

- Place carriage at left margin.
- Set up character M (1-34--78) in selector.
- Rotate main shaft until function clutch is in position "B."
- Hold check pawl away from ratchet.

Requirement — 0.005 to 0.020 inch between surface of feed pawl and face of ratchet tooth.

Adjust — Loosen clamp nut.

Move the whole assembly all the way to the left.

Position spacing drive roller with the eccentric.

Tighten clamp nut and recheck requirement.

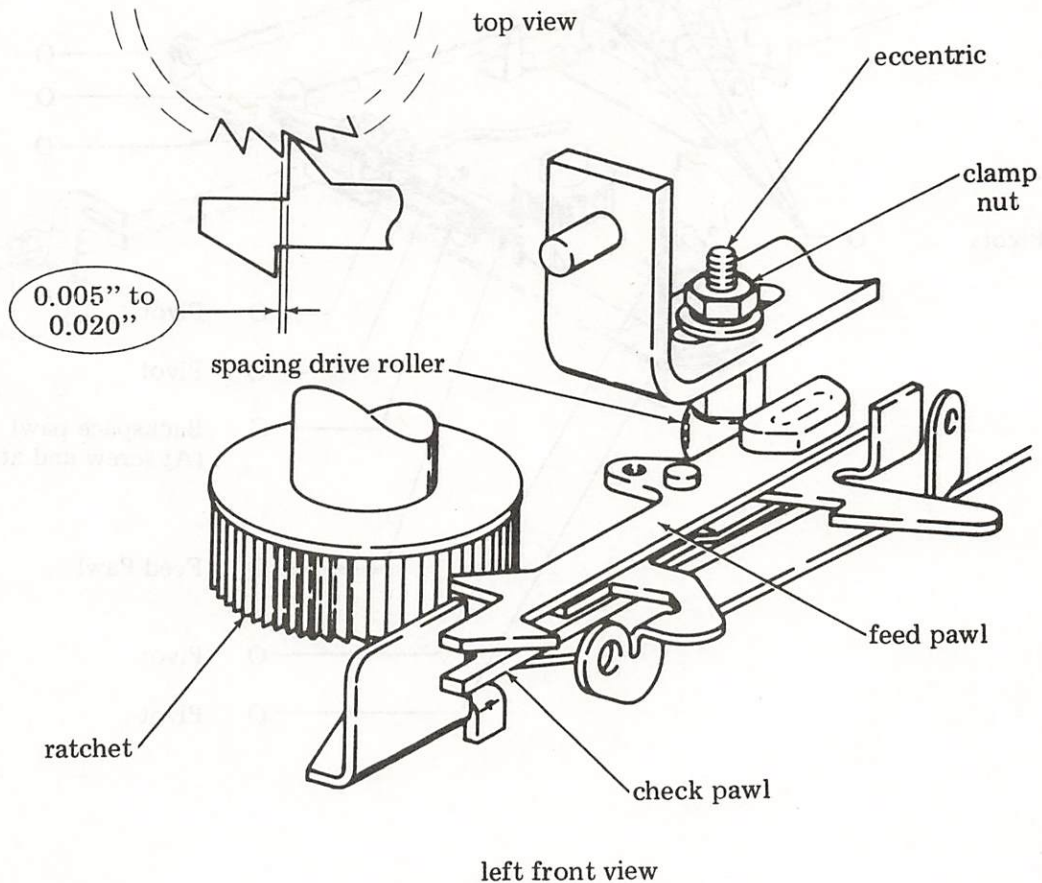

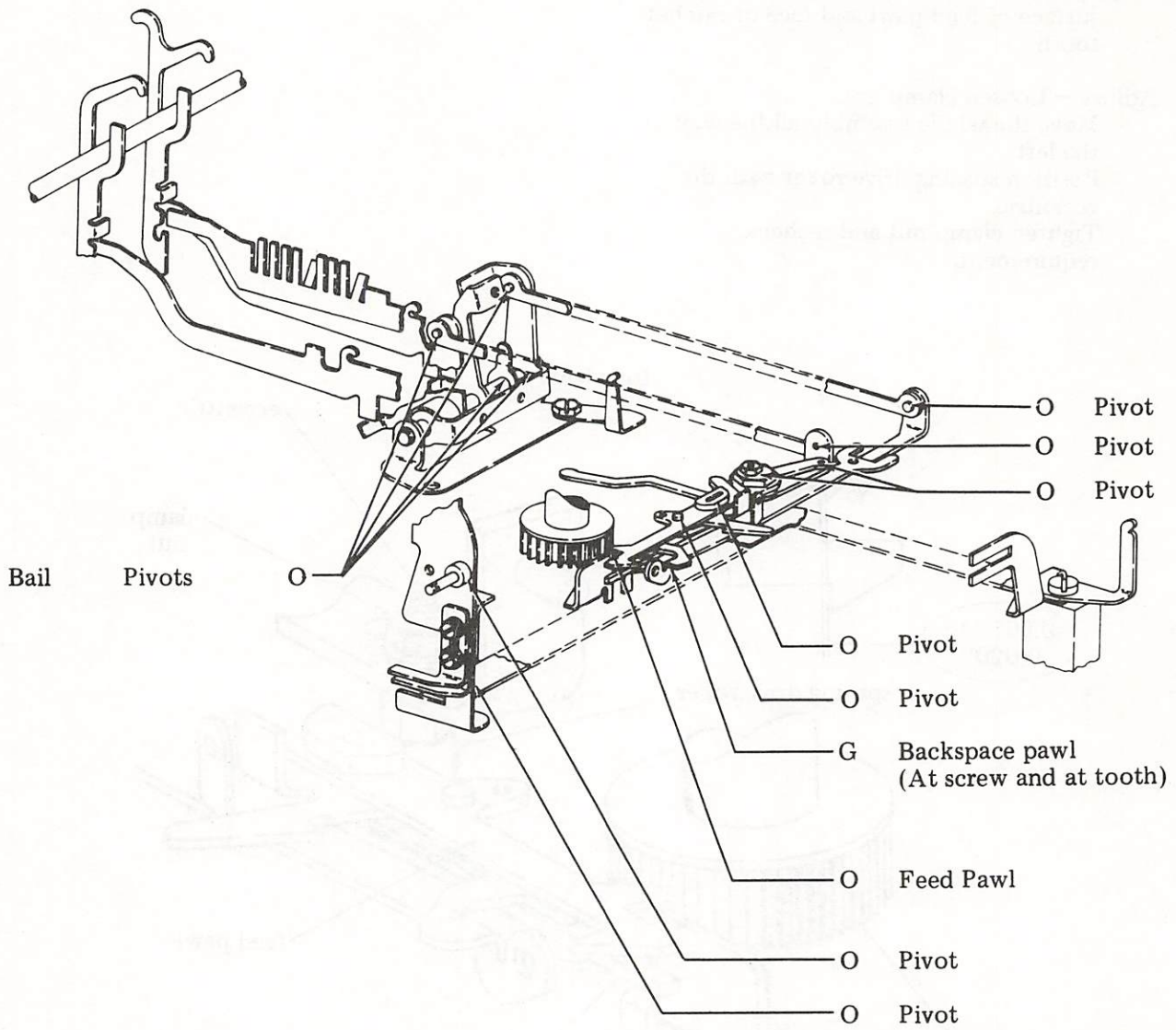

- 343693GF Modification Kit — Provides a shelf assembly for attendant set mounting on 38 KSR and ASR Sets.

This modification requires no maintenance. If it becomes necessary to remove the shelf, remove mounting hardware and pull the shelf. If adhesive remains attached, remove it with a mild detergent. DO NOT USE SOLVENTS.

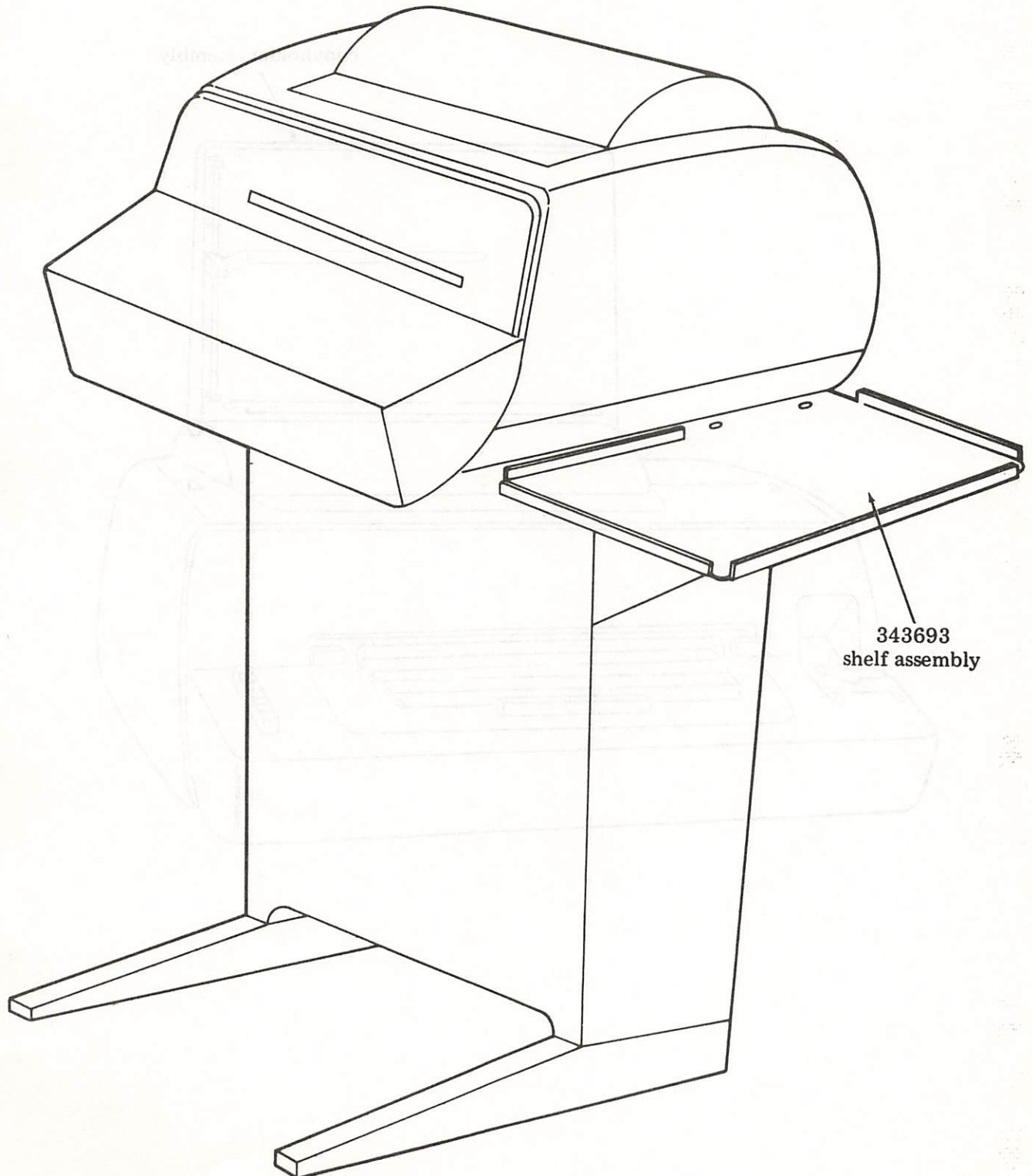

● 188500 Modification Kit — To equip Model 38 terminal with copyholder.

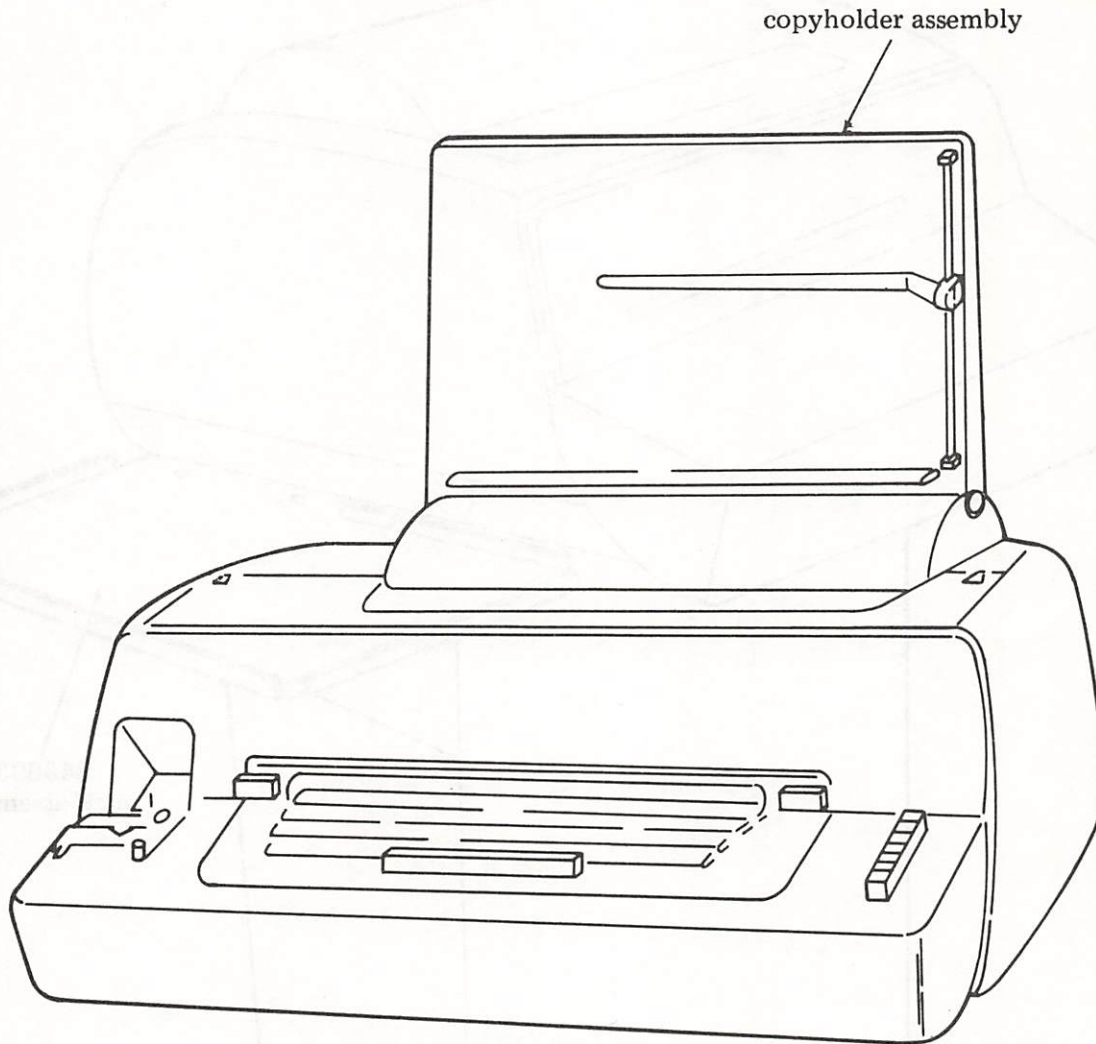

- 188860 Modification Kit — To convert Model 38 wide platen sprocket feed printer to accept 8-1/2 inch sprocket feed paper.

Description

8.10 The 188860 modification kit adapts wide platen (14-7/8 inch) sprocket feed printer to use 8-1/2 inch wide sprocket fed forms (Figure 26).

8.11 With this modification, the printer suppresses spacing at the end of the line. There is no automatic carriage return-line feed with this modification. Carriage return and line feed are distinct functions and must be performed manually.

Adjustments

8.12 For all adjustments pertinent to this modification, refer to Section 574-422-700TC.

Disassembly and Reassembly

8.13 To disassemble, proceed as follows:

- Remove paper tray.
- Remove cable tie on rear tie bar of platen assembly.
- Remove belts on sprocket assembly.
- Remove low paper alarm switch.
- Remove platen assembly.

To reassemble, reverse disassembly procedure.

Lubrication

8.14 Similar to wide platen. Add a few drops of oil to the new guides at both ends of the 8-1/2 inch platen.

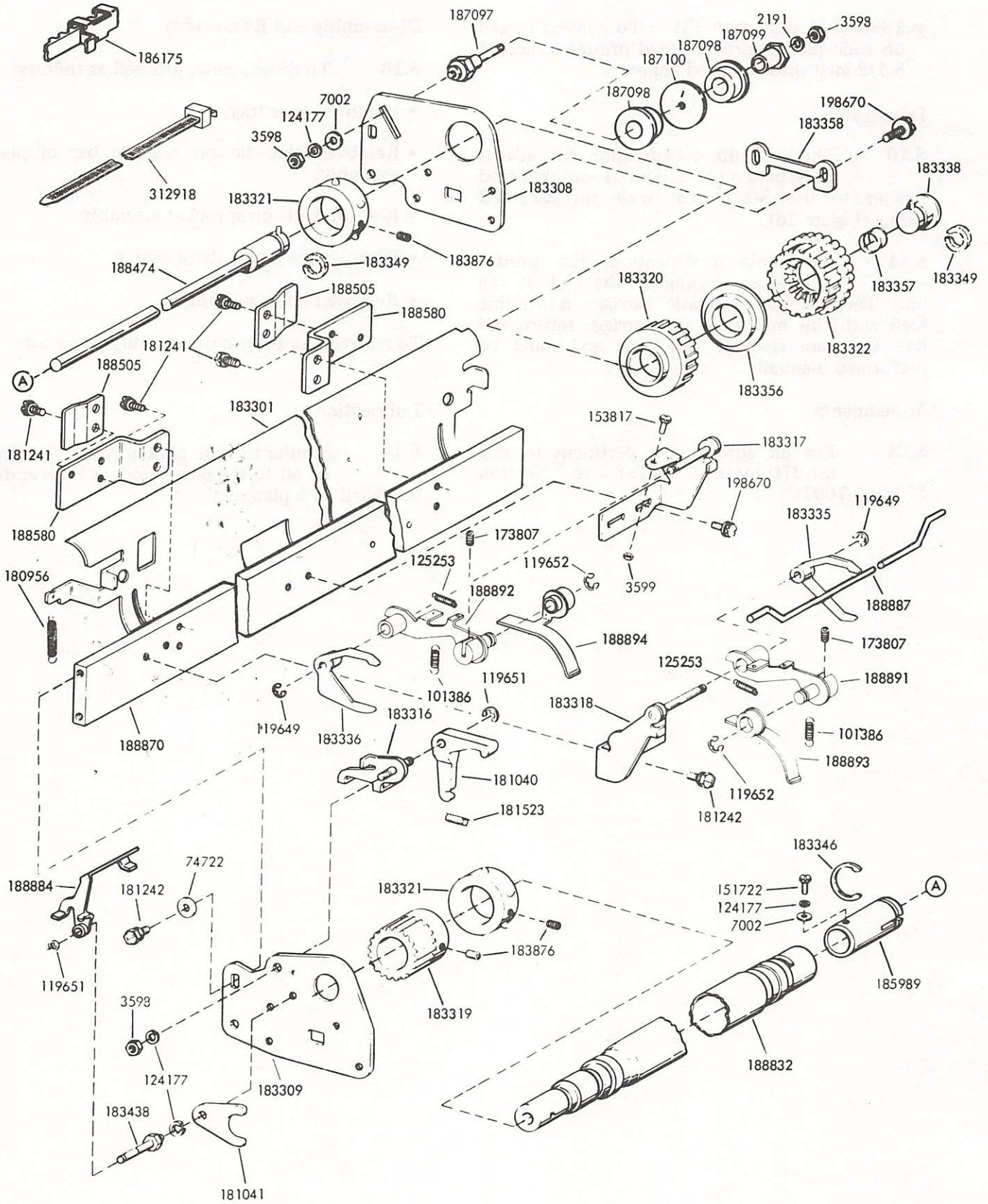
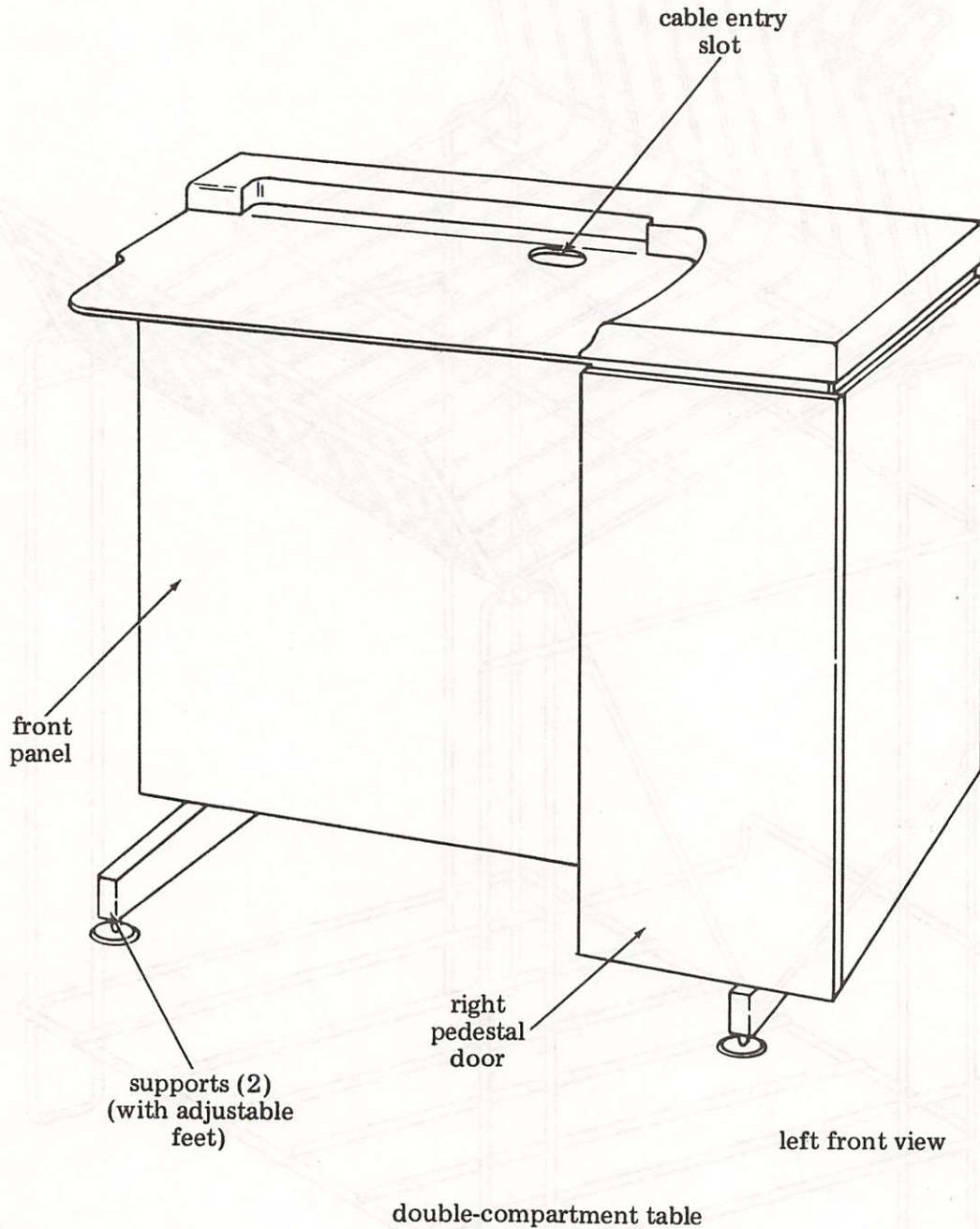
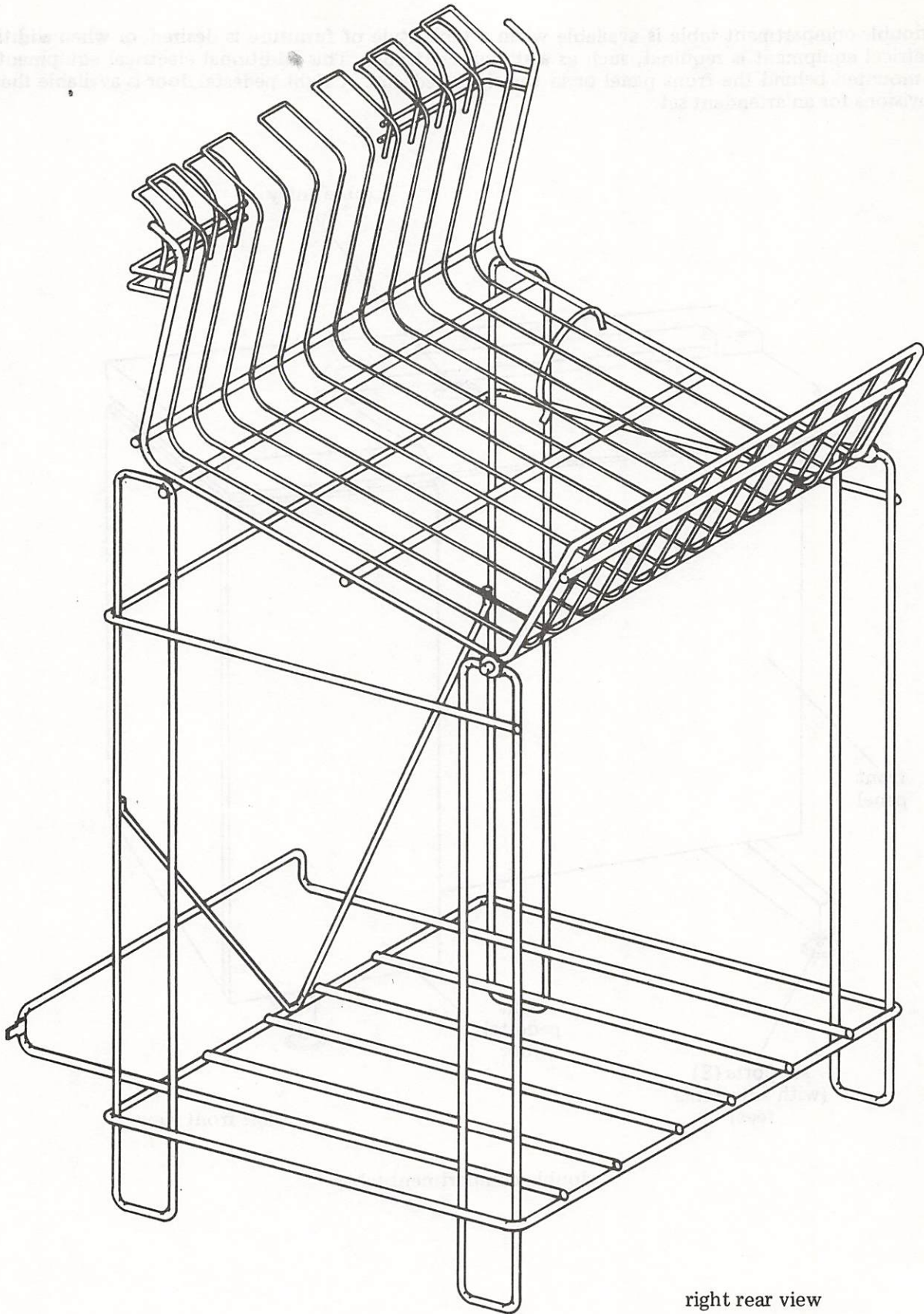

Figure 26 - 188860 Modification Kit to Convert Wide Platen Sprocket Feed to 8-1/2 Inch Wide Sprocket Feed

● WT001 Table

A double-compartment table is available when a table-style of furniture is desired, or when additional electrical equipment is required, such as a station controller. This additional electrical equipment can be mounted behind the front panel or in the right pedestal. A right pedestal door is available that has provisions for an attendant set.





right rear view

● 188388 Low Tape Alarm Modification

When the tape supply becomes low, the arm closes a Micro Switch which causes the OFF/ALARM button (CLEAR/ALARM in modem sets) to light, indicating low tape.

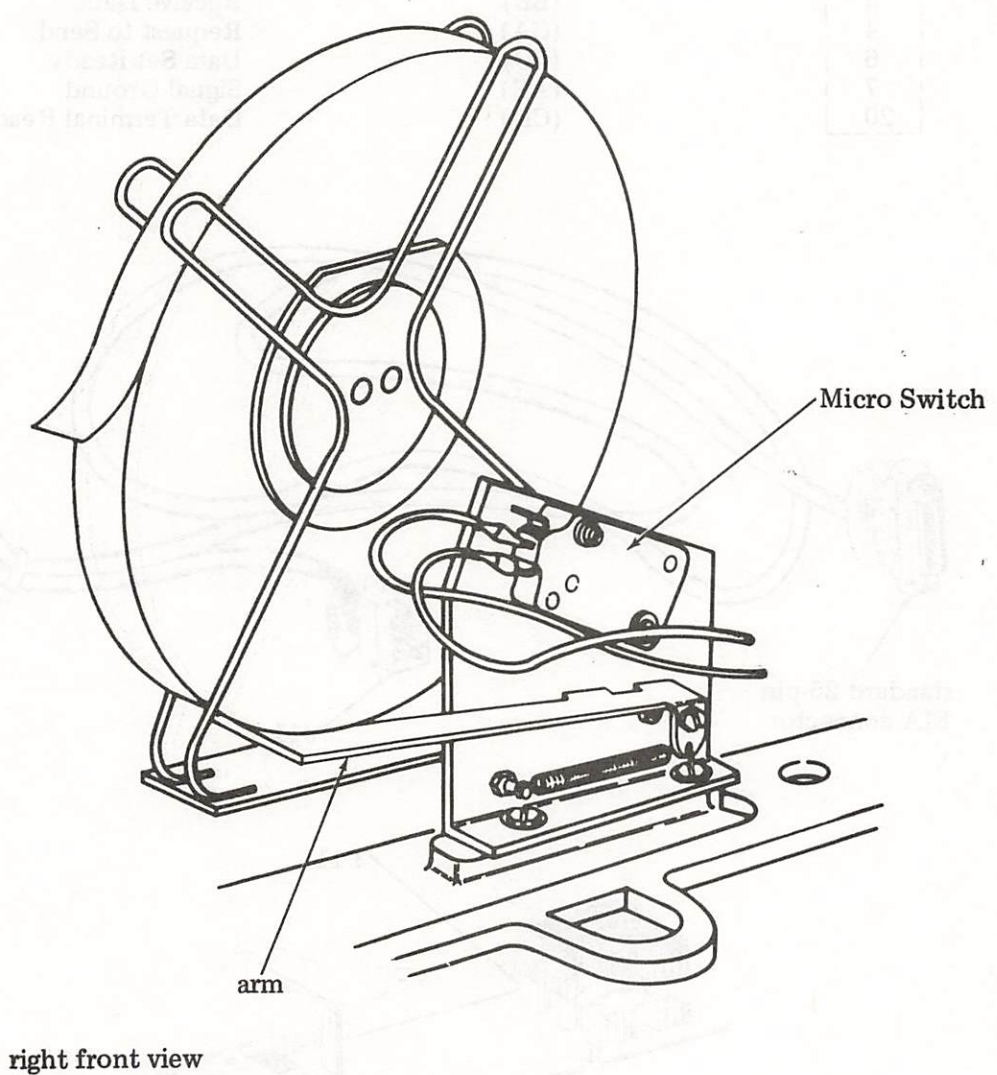

● 188724 Cable

As shipped from the factory, a Model 38 terminal equipped with WESU 001 can interface with other equipment or transmission system on a current basis. The 188724 cable allows the Model 38 terminal to interface with other equipment on an EIA (Electronic Industries Association — Standard RS-232-C) basis. Connector J11 of the cable connects to P11 on the circuit board of the WESU 001. The pin assignments on the EIA connector are as follows:

| EIA CONNECTOR PIN NO. | DESIGNATION | DEFINITION |
|-----------------------------|-------------|---------------------|
| 1 | (AA) | Protective Ground |
| 2 | (BA) | Send Data |
| 3 | (BB) | Receive Data |
| 4 | (CA) | Request to Send |
| 6 | (CC) | Data Set Ready |
| 7 | (AB) | Signal Ground |
| 20 | (CD) | Data Terminal Ready |

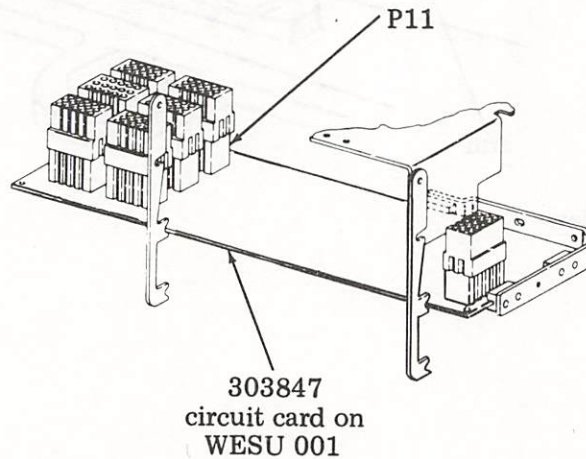
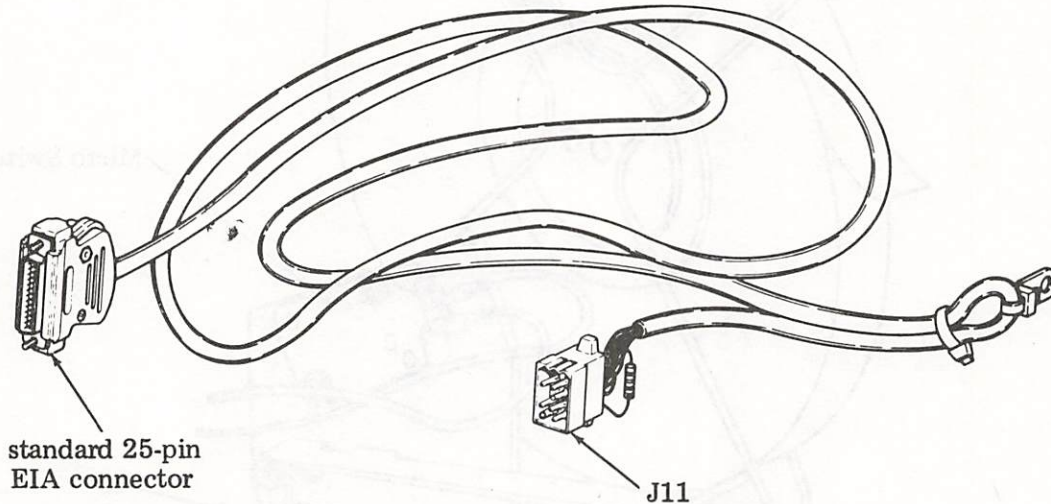

38 AUTOMATIC SEND-RECEIVE (ASR) TELETYPEWRITER SETS

TROUBLESHOOTING

| CONTENTS | PAGE |
|---------------------------------|------|
| 1. GENERAL | 1 |
| 2. CHECKOUT PROCEDURE | 1 |
| 3. TROUBLESHOOTING | 2 |
| 4. REFERENCES | 2 |

1. GENERAL

1.01 This section provides troubleshooting information for the 38 Automatic Send-Receive (ASR) Teletypewriter Sets. It includes checkout procedures and trouble analysis for routine or emergency maintenance. It is reissued to make corrections in the supplied schematic diagrams. Marginal arrows indicate the corrections.

1.02 A complete checkout procedure is provided in three tables. Table 1 covers off-line operation of the teletypewriter. Tables 2 and 3 cover on-line operation with a remote terminal.

1.03 Troubleshooting information is also provided in three tables. Table 4 covers troubleshooting routines for off-line failures, whereas Tables 5 and 6 cover on-line problems.

2. CHECKOUT PROCEDURE

2.01 Each step of the checkout routine consists of an operation, a normal response, and a trouble reference for use if the equipment does not respond as indicated. The trouble references key the checkout steps to the corresponding troubleshooting tables.

2.02 The checkout tables are arranged to verify one phase or mode of operation before proceeding to the next. It is important to perform the checkout in the order given.

2.03 Where an option affects the operation of the unit, the option is summarized in the table. Refer to Installation and Servicing Manual 341 for details on these options.

2.04 Where the variable features of the 38 teletypewriter affect the checkout procedure, the features are specified in the table (ie, sprocket feed vs friction feed). If no restrictions are listed, the checkout steps apply to all units.

2.05 Two electrical service units are available for the 38 teletypewriter. The WESU001 electrical service unit adapts the teletypewriter for use on a 20 ma or 60 ma dc signal line, or provides an interface compatible with 100 series data sets or equivalent EIA devices. Sets with this ESU are referred to as DC/EIA units in the checkout and troubleshooting tables. They have a single row of controls to the right of the keyboard.

2.06 The WESU002 electrical service unit includes a frequency shift keying modem which permits data interchange with a remote data set or equivalent device. Sets with this ESU are referred to as FSK units in the checkout and troubleshooting tables. They have a double row of controls to the right of the keyboard. For operation on a switched network, the FSK modem is commonly used with a data access arrangement (DAA) and telephone handset.

2.07 Before starting the checkout procedure, depress the STOP or CLEAR button on the control strip and place the tape punch and reader levers in the OFF and STOP positions, respectively. Load the typing unit with paper, and load the punch with tape. Make sure the ribbon is in good condition, and is correctly loaded in the typing unit. For sprocket feed units, set the rocker on the right end of the platen for single line feed (press lower arm of rocker). If an FSK set has an auto answer DAA, place the DAA in the voice mode.

2.08 For all installations, proceed with the off-line checkout of Table 1. When the terminal responds favorably to all of the off-line tests, proceed to either Table 2 or Table 3 for the on-line tests. If it is impossible to observe the operation of the remote terminal, contact the remote operator (ie, by telephone, or by talk mode of data set if so equipped) and determine the most convenient method of checking the data

interchange during the on-line tests. Be sure to identify the features of the remote terminal (ie, half-duplex vs full duplex, answer-back capabilities, etc).

3. TROUBLESHOOTING

3.01 Troubleshooting information is presented in three tables. Table 4 covers off-line failures. For convenience, troubles are grouped according to component (ie, typing unit, answer-back, etc). Tables 5 and 6 cover on-line troubles in DC/EIA and FSK terminals, respectively. In each table, the trouble symptom is described, and the methods of analyzing and correcting the trouble are listed.

3.02 In some cases a variety of troubles can lead to the same symptom. In these cases, the analysis either checks the most likely trouble points first or provides a series of steps to isolate the trouble to a given area.

3.03 Troubles related to only sprocket feed units, wide platen units, etc, are clearly indicated in the tables. Also, if the analysis differs for units equipped with the DC/EIA or FSK interface, the differences are indicated in the tables.

3.04 Voltage or continuity tests are required in troubleshooting some problems. Unless otherwise specified, dc voltages are measured between the indicated test points and ground (DC/EIA interface — J11, pin 7; FSK interface J14, pin 5). Voltage tests are made with the power on and the unit operating (to the extent possible) as specified in the test procedure. Caution must be observed in the placement of the voltmeter test probes to avoid shorts between terminals.

3.05 Continuity tests are made with the power off. Simplified schematic diagrams are provided in this section to aid in tracing the circuits and checking continuity. Wiring diagrams of the complete set are available in the wiring diagram package supplied with the unit.

3.06 Adjustments are made and mechanical operation is best observed with the power off. The unit can be cycled manually to check the mechanical operation and to check contact operations for continuity tests.

CAUTION: TO MINIMIZE SHOCK HAZARD AND AVOID DAMAGE TO COMPONENTS, REMOVE AC POWER BEFORE REPLACING FUSES OR PERFORMING CONTINUITY TESTS.

3.07 Field troubleshooting is intended to locate a trouble area and restore operation as quickly as possible. The repair should be limited to adjustments, lubrication, spring replacements, and other minor routines as stated in the troubleshooting charts. For major repairs, the failing component is usually replaced to restore operation, then repaired in the service shop or returned to a service center with suitable facilities. For troubles not covered in the troubleshooting tables, consider the following:

- (1) Exercise locally established routines (contact supervisor, contact service center, etc).
- (2) Review operating principles of unit and observe operation of failing component to determine where failure occurs.
- (3) Restore any phase of operation that can be provided until the source of trouble has been located and repaired (ie, if receive operation is normal but send operation fails, inform outlying stations that the unit will be operating as a receive-only terminal until the repair is complete).
- (4) If extensive repair is required, replace the entire unit to restore operation until repairs are made.

3.08 A complete set of wiring diagrams is supplied with the 38 teletypewriter. These diagrams show all electrical connections, including options and variable features, and are essential in troubleshooting the electrical circuits of the unit. To further assist in electrical troubleshooting, simplified schematic diagrams are included in this section (Figures 5 thru 18). These simplified diagrams show the components and connections related to various functions of the 38 teletypewriter, and in many cases are referred to in the troubleshooting tables.

4. REFERENCES

4.01 In addition to the wiring diagrams, and the installation and servicing manual supplied with the 38 teletypewriter, the following publications are recommended for reference in troubleshooting.

Set

| | |
|---------------------------------------|---------------|
| Description and Operation | 574-400-100TC |
| Removal and Replacement of Components | 574-400-702TC |

Keyboard

| | |
|-----------------------------------------|---------------|
| Description and Principles of Operation | 574-421-100TC |
| Adjustment | 574-421-700TC |
| Lubrication | 574-421-701TC |
| Disassembly and Reassembly | 574-421-702TC |
| Parts | 574-421-800TC |

Typing Unit (Including Answer-Back)

| | |
|-----------------------------------------|---------------|
| Description and Principles of Operation | 574-422-100TC |
| Adjustment | 574-422-700TC |
| Lubrication | 574-422-701TC |
| Disassembly and Reassembly | 574-422-702TC |
| Parts | 574-422-800TC |

Electrical Service Unit

| | |
|-----------------------------------------|---------------|
| Description and Principles of Operation | 574-423-100TC |
| Disassembly and Reassembly | 574-423-702TC |
| Parts | 574-423-800TC |

Tape Reader

| | |
|-----------------------------------------|---------------|
| Description and Principles of Operation | 574-424-100TC |
| Adjustment | 574-424-700TC |
| Lubrication | 574-424-701TC |
| Disassembly and Reassembly | 574-424-702TC |
| Parts | 574-424-800TC |

Tape Punch

| | |
|-----------------------------------------|---------------|
| Description and Principles of Operation | 574-425-100TC |
| Adjustment | 574-425-700TC |
| Lubrication | 574-425-701TC |
| Disassembly and Reassembly | 574-425-702TC |
| Parts | 574-425-800TC |

Cover

| | |
|----------------------------|---------------|
| Adjustment | 574-426-700TC |
| Lubrication | 574-426-701TC |
| Disassembly and Reassembly | 574-426-702TC |
| Parts | 574-426-800TC |

TABLE 1
CHECKOUT PROCEDURE — OFF-LINE OPERATION

NOTE: Trouble references in this table apply to Table 4.

| STEP | OPERATION | RESPONSE | TROUBLE REFERENCE |
|---------------------------------|-----------------------------------------------------------------------------------------|----------------------------------------------------------------------------------------------------------------------------------------------------------------------------------------------------------------------------------------|-----------------------------------------|
| CONTROL PANEL | | | |
| 1 | Depress LOCAL button on control strip. | LOCAL button lights and locks in depressed position. Motor turns on. | 1, 2, 3 |
| 2 | <u>Units Equipped With Answer-Back</u> Depress HERE IS button on control strip. | Answer-back mechanism goes through one cycle and answer-back sequence is printed out. | 44-48 |
| 3 | Depress BREAK button on control strip. | Typing unit cycles as long as button is held depressed, but no printing or spacing occurs. <i>NOTE: Random character or space may occur when button is released.</i> | 8 |
| KEYBOARD AND TYPING UNIT | | | |
| 4 | Depress LOCAL RETURN button on front of cover. | Carriage returns to left margin with no excessive bounce. | 37 |
| 5 | <u>Wide Platen Units</u> Momentarily depress PAPER ADVANCE button on front of cover. | Paper advances as long as button is depressed. | 34 |
| 6 | Depress ESCAPE key and then 4 key in sequence. | Typing unit cycles for each key, but no printing or spacing occurs. | 9, 42 |
| 7 | Depress each graphic key on keyboard to its normal downstop position. | Keyboard trips for each key depressed. No evidence of binding or double tripping. Typing unit prints selected characters. If two-color ribbon is used, characters are the color of the upper field of the ribbon. | 9 10, 11 13, 17 24 |

TABLE 1

CHECKOUT PROCEDURE — OFF-LINE OPERATION (Continued)

| STEP | OPERATION | RESPONSE | TROUBLE REFERENCE |
|--------------|---------------------------------------------------------------------------------------------------------------------------------------------------------------------------|----------------------------------------------------------------------------------------------------------------------------------------------------------------------------------------------------------------------------------------------------------------------------------------------------------------------------------------------------------------------------------------------------------------------------------------------------------------------------------------------------------------------------------------------------------------------------------------|----------------------------------|
| 7 (contd) | | <p>Option: Printed alphabetic will be lower case unless keyboard circuit card is programmed to convert lower case to capital alphabetic.</p> <p>Characters are printed with uniform shading and spacing.</p> | 25-32 |
| 8 | Depress user-selected "repeat" keys to the repeat position (beyond normal downstop position). Allow typing unit to print one complete line of a repeat graphic character. | <p>Characters are repeated as long as keys are held depressed. Depending on characters, printing or spacing may or may not occur.</p> <p>Repeated graphic should be uniformly spaced across entire line.</p> <p>End of line bell rings when typing carriage approaches right end of line.</p> <p>Option: If automatic carriage return and line feed feature is used, carriage returns to left margin and line feed occurs when carriage reaches right end of line. If feature is not used, characters pile up at right end of line unless line feed and carriage return are keyed.</p> | 12 31 41 40 |
| 9 | Depress SHIFT (either side) and SHIFT LOCK keys. | SHIFT keys are locked in depressed position. | 16 |
| 10 | Depress each graphic key to normal downstop position. | <p>Typing unit prints upper case character for each key depressed.</p> <p><i>NOTE: Numeral 0 key cannot be depressed in shift mode because it has no shifted equivalent.</i></p> | 14 |
| 11 | Depress and release SHIFT LOCK key. | SHIFT keys return to normal position. | 16 |
| 12 | Depress ESCAPE key and 3 key in sequence. | Typing unit cycles for each key, but no printing or spacing occurs. | 9, 42 |
| 13 | Depress several graphic keys to normal downstop positions. | Printed characters are the color of the lower field of the ribbon. | 24 |

TABLE 1

CHECKOUT PROCEDURE — OFF-LINE OPERATION (Continued)

| STEP | OPERATION | RESPONSE | TROUBLE REFERENCE |
|------|------------------------------------------------------------------------------------------------------------------------------------------------|--------------------------------------------------------------------------------------------------------------------------------------------------------------------------------------------------------------------------------------------|-------------------|
| 14 | Depress ESCAPE key and then 4 key to restore upper field of ribbon. | Typing unit cycles but no printing or spacing occurs. | 9, 42 |
| 15 | Depress LINE FEED key. | Single line feed occurs each time LINE FEED key is depressed. Option: If carriage return on line feed feature is used, carriage return will occur during line feed. | 33 |
| 16 | <u>Sprocket Feed Units</u> Set rocker on right side of platen for double line feed (press upper arm of rocker), then depress LINE FEED key. | Double line feed occurs each time LINE FEED key is depressed. | 33 |
| 17 | <u>Sprocket Feed Units</u> Restore single/double line feed rocker to single line feed position. | | |
| 18 | <u>Sprocket Feed Units</u> Depress CONTROL and FF keys simultaneously. | Paper advances rapidly to end of form and stops. <i>NOTE: Depressing CONTROL and FF a second time will not cause another form feed. At least one line feed must occur on the new form before another form feed can be produced.</i> | 35 |
| 19 | Depress spacebar several times, or if spacebar is repeatable, hold bar in repeat position to produce several spaces. | Typing carriage moves one space to right for each space. | 38 |
| 20 | Depress BACK SPACE key. | Typing unit cycles but no printing or spacing occurs. | 9, 42 |
| 21 | Depress CONTROL key and BELL key simultaneously. | Bell rings for each depression. No printing or spacing occurs. | 41 42 |
| 22 | Depress NULL key. | Typing unit cycles but no printing or spacing occurs. | 42 |
| 23 | Depress DELETE key. | Typing unit cycles but no printing or spacing occurs. | 42 |

TABLE 1

CHECKOUT PROCEDURE — OFF-LINE OPERATION (Continued)

| STEP | OPERATION | RESPONSE | TROUBLE REFERENCE |
|-------------------|----------------------------------------------------------------------------------------------------------------------------------------------------------------|--------------------------------------------------------------------------------------------------------------------------------------------------------------------------------------------------------------------------------------------------------------------------------------------------------------------------------------------------------------------------|---------------------------------------------------------|
| 24 | Depress TAB key. | Typing unit cycles but no printing or spacing occurs. | 42 |
| 25 | <u>Friction Feed Units</u> Lift roll of paper at rear of cabinet to simulate a "low paper" condition. | ALARM lamp lights (red) when roll of paper is lifted. | 43 |
| 26 | <u>Sprocket Feed Units</u> Tear off next form to simulate a "paper out" condition. Feed form by depressing CONTROL and FF keys or manually rotating platen. | ALARM lamp lights (red) when last form is fed into platen area. | 43 |
| 27 | <u>Sprocket Feed Units</u> Reload paper in typing unit. | ALARM lamp goes out. | 4 |
| TAPE PUNCH | | | |
| 28 | Set punch lever to ON position. | No noticeable effect. | |
| 29 | Depress DELETE key at least 20 times, or if DELETE key is repeatable, hold key depressed until at least 20 deletes are produced. | Typing unit cycles for each delete character. No printing or spacing occurs. Tape feeds one position for each delete character, and series of all marking codes are punched in tape. <i>NOTE: Eighth bit will be punched if unit is programmed for even parity or eighth bit always marking.</i> Punched holes should be spaced 10 per inch. | 9 42 49, 50, 51 54 |
| 30 | Depress NULL key several times, or if repeatable, hold key depressed until several nulls are produced. | Typing unit cycles for each null character. No printing or spacing occurs. | 9 42 |

TABLE 1

CHECKOUT PROCEDURE — OFF-LINE OPERATION (Continued)

| STEP | OPERATION | RESPONSE | TROUBLE REFERENCE |
|---------------|------------------------------------------------------------------------------------------------------------------------------------------------------------------------------------------------------------------------------------------------------------------------------------------------------------------------------------------------------------------------------------------------------------------------------------------------------------------------------------|----------------------------------------------------------------------------------------------------------------------------------------------------------------------------------------------------------------------------------------------------------------------------------------------------------------------------------------------------------------------------------------------------------------------------------------------------------------------------------|-------------------|
| 30 (contd) | | <p>Tape feeds one position for each null character, and no holes (other than feed holes) are punched in tape.</p> <p><i>NOTE: Eighth bit will be punched if unit is programmed for odd parity or eighth bit always marking.</i></p> | 49, 50, 51 |
| 31 | <p>Type the following test message: DELETE DELETE DELETE CR LF DELETE The quick brown fox jumped over the lazy dogs back 1234567890 times. CR LF DELETE ESCAPE 3 THE QUICK BROWN FOX JUMPED OVER THE LAZY DOGS BACK 123456789 TIMES. CR LF DELETE ESCAPE 4 The quick brown fox jumped over the lazy dogs back 1234567890 times. CR LF DELETE DC3 The quick brown fox jumped over the lazy dogs back 1234567890 times. CR LF DELETE EOT</p> | <p>Typing unit prints graphics.</p> <p>Tape advances one character position for each keyboard operation.</p> <p>Code characters are punched in tape according to ASCII chart of Figure 1.</p> <p><i>NOTE: Presence or absence of eighth bit depends on parity of unit.</i></p> <p><u>Option:</u> If keyboard circuit card is programmed to convert lower case to capital alphabets, all graphics (printed and punched) will be capitals in either shifted or unshifted mode.</p> | |
| 32 | Type a series of alternate r and y characters. | Typing unit prints and tape unit punches the r and y characters. | |
| 33 | Move the punch lever to the B.SP. position three times. | <p>Tape backspaces three positions.</p> <p>No effect on typing unit.</p> | 52 |
| 34 | Type a series of at least three delete characters. | <p>Tape advances one position for each delete character.</p> <p>Previously punched characters are repunched to form all marking delete characters, with no evidence of tearing of feed holes or punch holes.</p> <p>Typing unit cycles but does not print or space.</p> | 54 |
| 35 | Depress CONTROL and DC4 keys simultaneously. | Typing unit cycles but does not print or space. | 9, 42 |

TABLE 1

CHECKOUT PROCEDURE — OFF-LINE OPERATION (Continued)

| STEP | OPERATION | RESPONSE | TROUBLE REFERENCE |
|--------------------|---------------------------------------------------------------------------------------------------------------|-----------------------------------------------------------------|-------------------|
| 36 | Type a series of delete characters. | Typing unit cycles but does not print or space. | 9, 42 |
| | | Punch disabled by DC4 character. | 55 |
| 37 | Depress CONTROL and DC2 keys simultaneously. | Typing unit cycles but does not print or space. | 9, 42 |
| 38 | Type a series of delete characters. | Typing unit cycles but does not print or space. | 9, 42 |
| | | Tape advances and delete characters are punched in tape. | 53 |
| 39 | <u>Punch Equipped for Low Tape Alarm</u> Lift tape roll at rear of punch to simulate a tape-out condition. | ALARM lamp lights (red). | 56 |
| | | Lamp goes out when tape roll is replaced. | |
| 40 | Move punch lever to OFF position. | | |
| TAPE READER | | | |
| 41 | Load previously prepared test tape into reader. | | |
| 42 | Operate typing unit as necessary to begin a new line (friction feed) or new form (sprocket feed). | | |
| 43 | Move reader control lever to START position. | Tape moves through reader. | 57 |
| | | Typing unit prints out characters punched on test tape. | 61 |
| | | For nonprint characters, typing unit cycles but does not print. | |
| | | Depending on character, spacing may or may not occur. | |
| | | Line feeds, carriage returns, etc, occur as punched in tape. | |
| | If equipped for two-color printing, color changes after receipt of ESCAPE 3 or ESCAPE 4 sequence. | | |

TABLE 1

CHECKOUT PROCEDURE — OFF-LINE OPERATION (Continued)

| STEP | OPERATION | RESPONSE | TROUBLE REFERENCE |
|---------------|-------------------------------------------------------------------------------------------------------------------------------------------------------------------------------------------------------|----------------------------------------------------------------------------------------------------------------------------------------------------------------------------------------------------------------------------------------------------------------------------|-------------------|
| 43 (contd) | | If reader is strapped for automatic operation, reader stops upon recognition of DC3 or EOT, and is resumed by depressing CONTROL/DC1 on keyboard or by moving reader control lever to START position. Reader and typing unit stop when tight-tape condition occurs. | 66, 59 65 |
| 44 | Move reader control lever to STOP position and remove test tape from reader. | | |
| 45 | Tear off test tape at last character of printed message, and load piece of punched tape into reader. | | |
| 46 | Move reader control lever to START position and allow several characters to pass through reader, then move lever to STOP position. | Typing unit prints characters until lever is placed in STOP position. | |
| 47 | Move reader control lever to STEP position several times. | Tape advances one character position for each step. Typing unit responds to each character, step by step. | 60 |
| 48 | Move reader control lever to START position and allow remainder of test tape to feed through reader. <i>NOTE: For automatic readers, restart as necessary after reader detects DC3 or EOT.</i> | Typing unit reproduces message. Reader and typing unit stop when last character of tape is about four character positions from reader head. | |
| 49 | Move reader control lever to FREE position. | Tape can be moved freely in either direction through reader head. | 63 |
| 50 | Remove tape from reader and move control lever to OFF position. | | |
| 51 | Depress OFF (or CLEAR) button on control strip. | LOCAL button unlatches and lamp goes out. Motor turns off. | 7 |

TABLE 2

CHECKOUT PROCEDURE — ON-LINE WITH DC OR EIA INTERFACE

NOTE: Trouble references in this table apply to Table 5.

| STEP | OPERATION | RESPONSE | TROUBLE REFERENCE |
|------|----------------------------------------------------------------------------------------------------------------------------------------------------------------------------------------------------------------------------------------------------------------------------------------------------------------------------|-------------------------------------------------------------------------------------------------------------------------------------------------------------------------------------------------------------------------------------------|-------------------|
| 1 | <p>If other terminal is located remotely, contact operator at remote terminal (ie, by telephone) and arrange for a checkout. Have operator set remote terminal to line mode.</p> <p><i>NOTE: If EIA terminal is operating through 100 series data set or equivalent, perform standard call procedure for data set.</i></p> | | |
| 2 | Depress LINE button on control strip. | <p>LINE button lights and locks in depressed position.</p> <p>Motor turns on.</p> | 1 |
| 3 | Send message to remote terminal from keyboard, tape reader, or if local terminal has answer-back, by depressing HERE IS button. | Local terminal prints out message as it is transmitted to remote terminal. | |
| 4 | Verify accuracy of message received by remote terminal. | Received message should be error-free. | 5 |
| 5 | If remote terminal has send capability, have remote terminal transmit message to local terminal. | Received message should be error-free. | 6 |
| 6 | If local terminal is equipped with answer-back, and remote terminal has send capability, have remote terminal transmit ENQ to local terminal. | Answer-back sequence is printed out at local terminal and sent to remote terminal. | 9 |
| 7 | Depress LINE FDX button on control strip. | <p>LINE button unlatches and extinguishes.</p> <p>LINE FDX button lights and locks in depressed position.</p> | |
| 8 | Transmit message to remote terminal. | <p>Message should be received and processed with no errors by remote terminal.</p> <p><i>NOTE: If local terminal uses dc interface strapped for half-duplex operation, local terminal prints out message as it is transmitted. If</i></p> | 6 |

TABLE 2

CHECKOUT PROCEDURE — ON-LINE WITH DC OR EIA INTERFACE (Continued)

| STEP | OPERATION | RESPONSE | TROUBLE REFERENCE |
|--------------|-------------------------------------------------------------------------------------------------------------------------------------------------------------------------------------------------------------|----------------------------------------------------------------------------------------------------------------------------------------------------------------------------------------------------|-------------------|
| 8 (contd) | | <i>local terminal uses EIA interface, or dc interface strapped for full-duplex operation, local terminal does not print out message.</i> | |
| 9 | <u>Terminals Strapped for Full-Duplex Operation</u> With local terminal set to LINE FDX and remote terminal set for full duplex, arrange for local and remote terminals to send messages simultaneously. | Each terminal receives message sent by other terminal. No interference occurs between messages. | 6 |
| 10 | Depress LOCAL button on control strip. | LINE FDX button unlatches and extinguishes. LOCAL button lights and locks in depressed position. | |
| 11 | If remote terminal has send capability, have remote terminal attempt to send message to local terminal. | No response should be noted at local terminal (nor should any messages generated by local terminal be received by remote terminal). On-line send and receive functions are disabled in local mode. | |

TABLE 3

CHECKOUT PROCEDURE — ON-LINE WITH FSK INTERFACE

NOTE: Trouble references in this table refer to Table 6.

| STEP | OPERATION | RESPONSE | TROUBLE REFERENCE |
|------|-----------------------------------------------------------------------------------------------------------------------------------------------------------------------------------------------------------------------------------------------------------------------------------------------------------------|---------------------------------------------------------------------------------------------------------------------------------------------------------------------------------------------------------------------------------------------------------------------------------|-------------------|
| 1 | Lift telephone handset and dial remote terminal. <i>NOTE: If local terminal DAA is equipped for auto answer, lift exclusion key on telephone before dialing.</i> | Remote terminal sends f2m carrier (2225 Hz tone) when it has gone into answer mode. <i>NOTE: If remote terminal has auto answer capability, f2m carrier is automatically sent. If manual answer, remote operator must manually place remote terminal in answer mode.</i> | |
| 2 | Depress ORIG button. <i>NOTE: If local terminal DAA is equipped for auto answer, hang up handset. If manual answer, lift exclusion key and leave handset off-hook.</i> | Motor turns on and ORIG lamp lights. Local terminal sends f1m carrier (1270 Hz tone) to remote terminal to complete hookup. If remote terminal is equipped for auto answer-back, its answer-back sequence will be received and printed out by local terminal. | 1-5 |
| 3 | Transmit test message to remote terminal. Include a "return-to-voice" request at end of message to alert remote operator that voice communications are desired upon receipt of message. | Test message is printed out at local terminal and sent to remote terminal with no errors. | 7 |
| 4 | If local terminal DAA is equipped for auto answer, take telephone handset off-hook and lift exclusion key. If manual answer, depress exclusion key to middle position. Verify accuracy of test message, and ask remote operator to go into full duplex and send test message. Depress ORIG button as in Step 2. | | |
| 5 | Depress FDX button. | FDX button locks and lights. ORIG lamp lights upon receipt of f2m from remote terminal. | |

TABLE 3

CHECKOUT PROCEDURE — ON-LINE WITH FSK INTERFACE (Continued)

| STEP | OPERATION | RESPONSE | TROUBLE REFERENCE |
|------|--------------------------------------------------------------------------------------------------------------------------------------------------------------------------------------|-----------------------------------------------------------------------------------------------------------------------------------------------------------------------------------------------------------------------------------------------------------------------------------------------------------------------------------------------------------------------------------------------------------------------------------------------------------------------------|----------------------|
| 6 | Transmit message to remote terminal. <i>NOTE: Verify results of test by reverting to voice as in Step 4.</i> | Message does not print locally, but is sent to remote terminal with no errors. Message sent by remote terminal is simultaneously received and printed by local terminal with no errors. | 13 |
| 7 | Depress FDX button. | FDX button unlatches and extinguishes. | |
| 8 | Depress CLEAR button. | ORIG lamp extinguishes. <i>NOTE: On manual answer terminals, hang up telephone handset to complete disconnect.</i> | 12 |
| 9 | Have remote operator originate a call to local terminal. | <u>Terminal Equipped for Auto Answer</u> Telephone rings at local terminal. Motor turns on and local terminal sends f2m carrier to remote terminal. Remote terminal responds by sending f1m carrier to local terminal, and ANS button lights. If local terminal is equipped for auto answer-back operation, answer-back is sent to remote terminal. <u>Terminal Equipped for Manual Answer</u> Telephone rings at local terminal. | 4 4 15 |
| 10 | <u>Manual Answer Terminal</u> Lift telephone handset and agree by voice communications to go into answer mode. Depress ANS pushbutton and lift exclusion key on telephone. | Motor turns on and local terminal sends f2m carrier to remote terminal. Remote terminal responds by sending f1m carrier to local terminal, and ANS button lights. | 4 |

TABLE 3

CHECKOUT PROCEDURE — ON-LINE WITH FSK INTERFACE (Continued)

| STEP | OPERATION | RESPONSE | TROUBLE REFERENCE |
|---------------|---------------------------------------------------------------------------------------------------------------------------------------|--------------------------------------------------------------------------------------------------------------------------------------------------------------------------------------------------------------------------------------------------------------------------|-------------------|
| 10 (contd) | | If local terminal is equipped for answer-back operation, answer-back is sent to remote terminal. | 15 |
| 11 | Transmit message to remote terminal. | Test message is printed locally and sent to remote terminal with no errors. | 6, 7 |
| 12 | Have remote terminal set up for full duplex, then depress FDX button on local terminal. | FDX button locks and lights. | |
| 13 | Send message to remote terminal while simultaneously receiving message from remote terminal. | Transmitted message is received by remote terminal with no errors but does not print at local terminal. Message received from remote terminal is printed out with no errors. | 13 |
| 14 | Depress FDX button. | FDX button unlatches and extinguishes. | |
| 15 | Depress ECHO button. | ECHO button locks and lights. | |
| 16 | Have remote terminal transmit message to local terminal. <i>NOTE: Remote terminal must remain in full duplex for the test.</i> | Message sent by remote terminal is printed out by local terminal and simultaneously returned to remote terminal for printout. Message returned to remote terminal should be identical to message originally sent to local terminal. | 8, 14 |
| 17 | Depress ANS button. | ECHO button unlatches and extinguishes. | |
| 18 | Depress FDX button and transmit EOT to remote terminal. | Remote terminal turns off carrier. When loss of remote carrier is detected by local terminal, motor turns off and ANS lamp extinguishes. Auto answer terminal is now disconnected, but manual answer terminal must hang up handset to complete disconnect. | 11, 12 |

TABLE 3

CHECKOUT PROCEDURE — ON-LINE WITH FSK INTERFACE (Continued)

| STEP | OPERATION | RESPONSE | TROUBLE REFERENCE |
|------|----------------------------------------------------------------------------|------------------------------------------------------------------------------------------------------------------|-------------------|
| 19 | <u>Auto Answer Terminals</u> Depress LOCAL button. | LOCAL button locks and lights and motor turns on. | |
| 20 | <u>Auto Answer Terminals</u> Have remote station originate a call. | ANS button flashes with incoming ring signal. | 10 |
| 21 | <u>Auto Answer Terminals</u> Depress ANS button to go into answer mode. | LOCAL button unlatches and extinguishes. ANS button lights when carrier is received from remote terminal. | |
| 22 | Depress CLEAR button. | ANS button extinguishes and motor turns off. | 12 |

TABLE 4

TROUBLESHOOTING — OFF-LINE OPERATION

NOTE: Circuit common for voltage measurements is terminal 8 or 9 of card 303846.

| NO. | SYMPTOM | ANALYSIS AND CORRECTIVE MEASURES |
|--------------------------|----------------------------------------------------------------------------------------------------------------------------------------------|------------------------------------------------------------------------------------------------------------------------------------------------------------------------------------------------------------------------------------------------------------------------------------------------------------------------------------------------------------------------------------------------------------------------------------------------------------------------------------------------------------------------------------------------------------------------------------------------------------------------------------------------------------------------------------------------------------------|
| GENERAL OPERATION | | |
| 1 | Terminal completely inoperative. No indicator lamps light when buttons are depressed; motor does not turn on when LOCAL button is depressed. | <ul style="list-style-type: none"> (a) Make sure power cord is plugged into ac outlet. (b) Measure voltage at convenience outlet to verify presence of 115 v ac supply voltage. (c) Check ac supply fuse F1 and dc supply fuse F2 and replace if necessary. (d) Check for +24 v at P14, pin 6 of power supply. If not present, power supply may be defective. If present, trouble may be in circuit card 303847 (DC/EIA interface) or 322491 (FSK interface). |
| 2 | Individual indicator lamp does not light. (Lamp energized by control buttons only.) | Check for 24 v across lamp when corresponding control button is depressed. Refer to wiring diagram 1194SD (DC/EIA interface) or 1196SD (FSK interface) for connector pins. If voltage is present, indicator lamp may be defective. If not present, trouble may be in related switch contact or interface circuit card 303847 (DC/EIA) or 322491 (FSK). |
| 3 | Motor does not turn on when LOCAL button is depressed. LOCAL lamp lights. | <ul style="list-style-type: none"> (a) Depress LINE button (units with DC/EIA interface) or ANS button (units with FSK interface). If motor turns on, check LOCAL switch contacts and connector. (b) If motor hums but does not turn, check for binding or frozen main shaft. (c) If motor is completely inoperative, check motor fuse F4 (synchronous motors only). (d) Check voltage across motor. If 115 v ac is present, motor may be defective. (e) Check operation of motor control relay. (f) Trouble may be in interface circuit card 303847 (DC/EIA interface) or 322491 (FSK interface). See Figures 5 thru 8 for electrical check points. |
| 4 | ALARM lamp remains lit at all times. | (a) Determine if lamp is being held on by closure of paper alarm contacts. If punch is equipped for low tape alarm, also inspect low tape contacts. |

TABLE 4

TROUBLESHOOTING — OFF-LINE OPERATION (Continued)

| NO. | SYMPTOM | ANALYSIS AND CORRECTIVE MEASURES |
|--------------|------------------------------------------------------------------|-----------------------------------------------------------------------------------------------------------------------------------------------------------------------------------------------------------------------------------------------------------------------------------------------------------------------------------------------------------------------------------------------------------------------------------------------------------------------------------------------------------------------------------------------------------------------------------------------------------------------------------------------------------------------------------------------------------------------------------------------------------------------------------------------------------------------------------------------------------------------------------------------------------------------------------------------------------------------------------------------------------------------------------------------------------------------------------|
| 4 (contd) | | <p>(b) If above contacts function when operated manually, make sure paper and/or tape is correctly installed.</p> <p>(c) Refer to wiring diagrams of 1194SD or 1196SD for electrical connections related to paper alarm, tape out, and low tape (if included in punch).</p> <p>(d) If paper alarm contact operation is normal, circuit card 303847 (DC/EIA interface) or 322491 (FSK interface) may be defective.</p> |
| 5 | Typing unit runs open (continuously) when terminal is turned on. | <p>(a) Make sure selector armature is aligned correctly, and is free to operate.</p> <p>(b) Make sure H-plate between keyboard and typing unit is in place.</p> <p>(c) Check Shoe Lever Gap and Trip Lever Engagement adjustment in Section 574-422-700TC.</p> <p><u>DC/EIA Interface</u></p> <p>(d) Refer to Figure 5 or 6 for electrical check points.</p> <p>(e) Check voltage at J13, pin 9. If +24 v is present, BREAK switch contact may be open or there may be a poor contact in one of the cable connectors.</p> <p>(f) Check voltage at J15, pin 11. If +24 v is not present, check normally closed FDX contact. Check voltage at J12, pin 15. If +24 v is present, circuit card 303847 may be defective.</p> <p><u>FSK Interface</u></p> <p>(g) Refer to Figure 16 for electrical check points.</p> <p>(h) Check voltage at J15, pin 15. If +24 v is present, BREAK switch contact may be open.</p> <p>(i) Check voltage at J4, pin 9. If +24 v is present, circuit card 322491 may be defective. If no voltage is present, selector magnet coil may be defective.</p> |

TABLE 4

TROUBLESHOOTING — OFF-LINE OPERATION (Continued)

| NO. | SYMPTOM | ANALYSIS AND CORRECTIVE MEASURES |
|-----|----------------------------------------------------------------------------------------------------------------|-----------------------------------------------------------------------------------------------------------------------------------------------------------------------------------------------------------------------------------------------------------------------------------------------------------------------------------------------------------------------------------------------------------------------------------------------------------------------------------------------------------------------------------------------------------------------------------------------------------------------------------------------------------------------------------------|
| 6 | Terminal fails to operate from all sources (keyboard, answer-back, reader). | <p>Check the following adjustments in Section 574-422-700TC:</p> <p style="padding-left: 40px;">Shoe Lever Gap and Trip Lever Engagement Enable Contact Trip Lever Clearance Character Suppression Contact Wire Gap</p> <p><u>DC/EIA Interface</u></p> <p>(a) Refer to Figure 5 or 6 for electrical check points.</p> <p>(b) Check voltage at J15, pin 11 and J12, pin 15. If voltage is zero, circuit card 303847 may be defective.</p> <p><u>FSK Interface</u></p> <p>(a) Refer to Figure 16 for electrical check points.</p> <p>(b) While depressing BREAK button, check voltage at J4, pin 9. If positive voltage is present, circuit card 322491 may be defective.</p> |
| 7 | Terminal does not turn off when OFF or CLEAR button is depressed. | <p>(a) Determine if OFF or CLEAR switch mechanism is unlocking previously selected mode switch. If not, check mechanical locking arrangement between switches. Switch mechanism may be defective.</p> <p>(b) Check operation of OFF or CLEAR switch contacts. Refer to wiring diagram 1194SD and Figure 5 or 6 (DC/EIA interface) or Figure 9 (FSK interface) for circuitry involved.</p> |
| 8 | Typing unit does not run open (cycle continuously without printing or spacing) when BREAK button is depressed. | <p><u>DC/EIA Interface</u></p> <p>Check voltage at J13, pin 9. If voltage is zero with BREAK button depressed, break contact may be defective. If voltage is +24 v, circuit card 303847 may be defective. See Figure 5 (DC interface) or Figure 6 (EIA interface) for related circuitry.</p> <p><u>FSK Interface</u></p> <p>Check voltage at J15, pin 15. If voltage is +24 v with BREAK button depressed, break contact may be defective. If voltage is zero, circuit card 322491 may be defective. See Figure 16 for related circuitry.</p> |

TABLE 4

TROUBLESHOOTING — OFF-LINE OPERATION (Continued)

| NO. | SYMPTOM | ANALYSIS AND CORRECTIVE MEASURES |
|-----------------|------------------------------------------------------------------------------------------------|---------------------------------------------------------------------------------------------------------------------------------------------------------------------------------------------------------------------------------------------------------------------------------------------------------------------------------------------------------------------------------------------------------------------------------------------------------------------|
| KEYBOARD | | |
| 9 | Keyboard fails to trip when key is depressed. | <p>(a) Check to make sure H-plate and spring are correctly positioned on keyboard trip arm.</p> <p>(b) Make sure universal codebar and tie link are free to move, and that tie link moves non-repeat lever and latchlever to right, allowing universal lever to move up.</p> <p>(c) Check following adjustments in Section 574-421-700TC:</p> <p style="padding-left: 40px;">Universal Link Distributor Trip Linkage Trip Lever Engagement Trip Arm</p> |
| 10 | Keyboard double trips or runs continuously. | <p>(a) Check latchlever and nonrepeat lever for free operation.</p> <p>(b) Check Latchlever Spring and Nonrepeat Lever Spring adjustments in Section 574-421-700TC.</p> <p>(c) Check Trip Lever Engagement and Trip Arm adjustments in Section 574-421-700TC, and Shoe Lever Gap and Trip Lever Engagement adjustments in Section 574-422-700TC.</p> |
| 11 | Key binds. | Check for broken keytop guideplate, displaced keylever on return spring under guideplate, or bind in codebars or T-levers. |
| 12 | Repeat keys fail to generate repeat characters when fully depressed. | <p>(a) Make sure there is no obstruction in keylever slot.</p> <p>(b) Check for bind in keytop.</p> <p>(c) Check for bind in universal tie link and/or non-repeat lever.</p> <p>(d) Make sure repeat keylever engages nonrepeat lever.</p> |
| 13 | Incorrect characters produced by keyboard. (Answer-back or reader produces correct characters. | <p>(a) Make sure contact wires are correctly positioned on T-levers.</p> <p>(b) Check action of contact wires. Make sure bottom ends of contact wires are secure, and that contacts open and close according to code bits of character.</p> |

TABLE 4

TROUBLESHOOTING — OFF-LINE OPERATION (Continued)

| NO. | SYMPTOM | ANALYSIS AND CORRECTIVE MEASURES |
|--------------------|-----------------------------------------------------------------------------------------------------------------------------|-----------------------------------------------------------------------------------------------------------------------------------------------------------------------------------------------------------------------------------------------------------------------------------------------------------------------------------------------------------------------------------------------------------|
| 13 (contd) | | <p>(c) Check contact points for any foreign material. Clean as necessary.</p> <p>(d) Check Contact Wires adjustment in Section 574-421-700TC.</p> <p>(e) Remove keytop guideplate and make sure all codebars and tie links are correctly engaged with T-levers.</p> <p>(f) If contact wire operation is satisfactory, circuit card 322450 may be defective. See Figure 8 for electrical check points.</p> |
| 14 | No upper case characters in shift mode. (Answer-back or reader produces correct characters.) | <p>(a) Check movement of shift codebar and associated contact wire.</p> <p>(b) Check Left Shift Contact Wire and Shift Codebar Spring adjustments in Section 574-421-700TC.</p> <p>(c) If contact wire operation is satisfactory, circuit card 322450 may be defective. See Figure 8 for electrical check points.</p> |
| 15 | Control characters not produced from keyboard. (Answer-back or reader produces correct characters.) | <p>(a) Check movement of control codebar and associated contact wire.</p> <p>(b) Check CTRL Contact Wire adjustment in Section 574-421-700TC.</p> <p>(c) If contact wire operation is satisfactory, circuit card 322450 may be defective. See Figure 8 for electrical check points.</p> |
| 16 | SHIFT keys fail to lock when SHIFT LOCK key is depressed, or fail to unlock when SHIFT LOCK key is depressed a second time. | Remove keytop guideplate and observe mechanical linkage between shift and shift lock keylevers. |
| TYPING UNIT | | |
| 17 | Incorrect characters produced by keyboard, reader, and answer-back. | Adjust range finder setting. If no setting can be found which produces error-free operation, operate unit manually from keyboard and observe selection of push levers in selector. If character is incorrect at selector, refer to trouble No. 18. If character is correct at selector, but incorrect character is printed, refer to trouble No. 19. |

TABLE 4

TROUBLESHOOTING — OFF-LINE OPERATION (Continued)

| NO. | SYMPTOM | ANALYSIS AND CORRECTIVE MEASURES |
|-----|-------------------------------------------------------------------------------------------------------|----------------------------------------------------------------------------------------------------------------------------------------------------------------------------------------------------------------------------------------------------------------------------------------------------------------------------------------------------------------------------------------------------------------------------------------------------------------------------------------------------------------------------------------------------------------------------------------------------------------|
| 18 | Incorrect characters printed — selector push lever combinations do not correspond to character codes. | <p>(a) Check for loose selector magnet wires and/or connectors.</p> <p>(b) Check for missing springs in selector.</p> <p>(c) Check for dirt or oil on selector armature.</p> <p>(d) Check the following adjustments in Section 574-422-700TC:</p> <p style="padding-left: 40px;">Shoe Lever Gap and Trip Lever Engagement Armature Spring Armature Bracket Position (Preliminary) Belt Tension (Final) Gear Backlash</p> <p><i>NOTE: Refine Armature Bracket Position (Preliminary) adjustment by equalizing clearance between armature extension and No. 1 and No. 8 selector levers.</i></p> |
| 19 | Incorrect characters printed — selector produces correct code combination. | <p>Operate unit manually and observe selection of codebars.</p> <p>(a) If codebar combinations are incorrect for character selected, check Codebar Reset Lever Position and Selector Blocking Lever Positioning adjustments in Section 574-422-700TC.</p> <p>(b) If codebar combinations are correct for character selected, check all adjustments related to carriage area in Section 574-422-700TC.</p> |
| 20 | Function failures. | <p>(a) Check for bent function levers.</p> <p>(b) Check following adjustments in Section 574-422-700TC:</p> <p style="padding-left: 40px;">Function Lever Retainer Left Rocker Drive Right Rocker Drive Print Suppression Latch — Horizontal Clearance Print Suppression Latch — Vertical Clearance Function Shaft and Casting Position Function Clutch Trip Lever Engagement</p> |

TABLE 4
TROUBLESHOOTING — OFF-LINE OPERATION (Continued)

| NO. | SYMPTOM | ANALYSIS AND CORRECTIVE MEASURES |
|-----|-------------------------------------------------------------------------------------------------------------------------------------------------------------------------------------------|---------------------------------------------------------------------------------------------------------------------------------------------------------------------------------------------------------------------------------------------------------------------------------------|
| 21 | Function repeat. | Check following adjustments in Section 574-422-700TC: Stripper Bail Clearance Function Clutch Trip Lever Engagement |
| 22 | Failure to print at one end of carriage travel. | Check following adjustments in Section 574-422-700TC: Rear Rail Position Carriage Drive Bail Endplay |
| 23 | Ribbon fails to feed or feeds erratically. | (a) Make sure ribbon spool is seated correctly over feeding pin. (b) Check Ribbon Power Lever Drive adjustment in Section 574-422-700TC. |
| 24 | Ribbon does not shift for two-color printing. | (a) Make sure ribbon is installed correctly. (b) Check Color Selection Latch Overtravel adjustment in Section 574-422-700TC. |
| | <u>Friction Feed Units</u> | |
| 25 | All characters too light or too dark. | Check Platen — Horizontal Position adjustment in Section 574-422-700TC. |
| 26 | One side of character darker than the other. (All characters.) | Check Typewheel “Home” Position adjustment in Section 574-422-700TC. |
| 27 | One side of character darker than the other. (Characters in clockwise field of typewheel only, or in counterclockwise field only.) <i>NOTE: See Figure 2 for typewheel layout.</i> | (a) Check Stop Plate adjustment in Section 574-422-700TC. (b) Refine Typewheel “Home” Position adjustment if necessary. <i>NOTE: Check horizontal spacing of characters involved. If necessary, refine adjustments to provide best shading and spacing.</i> |
| 28 | All characters darker at top or bottom. | Check Vertical Type Alignment adjustment in Section 574-422-700TC |
| 29 | Horizontal spacing of characters varies. (All characters, or characters in either clockwise or counterclockwise field of typewheel — see Figure 2.) | (a) Check Stop Plate adjustment in Section 574-422-700TC. (b) Refine Typewheel “Home” Position adjustment if necessary. <i>NOTE: Check for uniform horizontal shading of characters involved. If necessary, refine adjustments to provide best shading and spacing.</i> |

TABLE 4

TROUBLESHOOTING — OFF-LINE OPERATION (Continued)

| NO. | SYMPTOM | ANALYSIS AND CORRECTIVE MEASURES |
|-----|----------------------------------------------------------------|------------------------------------------------------------------------------------------------------------------------------------------------------------------------------------------------------------------------------------------------------------------------------------------------------------------------------------------------------------------------------------------------------------------------------------------------------------------------------------------------------------------------------------------------------------------------------------------------------------------------------------------------------------------------------------------------------------------------------------------------------------------------------------------------------------------------------------------------------------------------------------------------------------------------------------------------------------------------------------------------------------|
| 30 | Incorrect spacing at left side of copy only. | Check following adjustments in Section 574-422-700TC: Spacing Belt Tension Left Margin Position Left Margin Printing |
| 31 | Repeated characters are unequally spaced at left side of copy. | (a) Check for bind in carriage rollers or dashpot plunger, or for out-of-parallel dashpot. (b) Check Reset Lever Positioning adjustment in Section 574-422-700TC. |
| 32 | Random characters are unequally spaced at left side of copy. | Check following adjustments in Section 574-422-700TC: Print Hammer Bail Spring Print Hammer Trip Lever Spring Power Bail Roller Clearance |
| 33 | Unit fails to line feed, or feeds erratically. | <u>Friction Feed Units</u> (a) Observe operation of line feed drive link. If drive link does not operate, check operation of line feed function lever and line feed blocking lever. (See trouble No. 4 for function failures.) Check Line Feed Drive Arm Clearance and Line Feed Upstop Bracket Position adjustments in Section 574-422-700TC. (b) If drive link moves through its full travel, or repeats, check Line Feed Stripper Plate Clearance adjustment in Section 574-422-700TC. (c) If drive link travels fully but does not drive platen fully, or drives too far, check following adjustments in Section 574-422-700TC: Line Feed Selection Detent Position Line Feed Drive Link Position Line Feed Pawl Downstop Position <u>Sprocket Feed Units</u> (a) If platen does not advance, check selection of line feed pawl in slot 13. (b) Check Line Feed Selection and Line Feed Pawl Stripping adjustments in Section 574-422-700TC. |

TABLE 4

TROUBLESHOOTING — OFF-LINE OPERATION (Continued)

| NO. | SYMPTOM | ANALYSIS AND CORRECTIVE MEASURES |
|---------------|-------------------------------------------------------------------------------------------------------|-------------------------------------------------------------------------------------------------------------------------------------------------------------------------------------------------------------------------------------------------------------------------------------------------------------------------------------------------------------------------------------------------------------------------------------------------------------------------------------------------------------------------------------------------------------------------------------------------------------------------------------------------------------------------------------------------------------------------------------------------------------------------------------------------------------------------------------------------------------------------------------------------|
| 33 (contd) | | <p>(c) If extra line feed occurs, check Line Feed Selection and Line Feed Pawl Stripping adjustments in Section 574-422-700TC.</p> <p>(d) If line feed is irregular, check Detent Position adjustment in Section 574-422-700TC.</p> |
| 34 | <p><u>Wide Platen Units</u></p> <p>Paper does not advance when PAPER ADVANCE button is depressed.</p> | <p>(a) Make sure cable to form feed mechanism is secure.</p> <p>(b) Check Paper Advance adjustment in Section 574-426-700TC.</p> |
| 35 | <p><u>Sprocket Feed Units</u></p> <p>Form feed does not operate or operates erratically.</p> | <p>(a) If form does not advance, check selection of form feed pawl in slot 14. If pawl selects but form does not advance, check for bind in reset follower lever.</p> <p><i>NOTE: Roller should rest on form-out cam disc after a line feed.</i></p> <p>Check following adjustments in Section 574-422-700TC:</p> <p style="padding-left: 40px;">Form-Out Lever Overtravel Form-Out Lever Reset Clearance Cam Lobe Position Form-Out Lever Spring</p> <p>(b) If form feed repeats, check following adjustments in Section 574-422-700TC:</p> <p style="padding-left: 40px;">Form-Out Lever Reset Clearance Cam Lobe Position Trip Lever Engagement — Final</p> <p>(c) If printed line is off, check Printing Line Position — Final adjustment in Section 574-422-700TC.</p> <p>(d) If zero pointer is off, check Cam Zero Position adjustment in Section 574-422-700TC.</p> |
| 36 | <p>Printer fails to carriage return when RETURN key is depressed.</p> | <p>(a) Check selection of function lever in slot 2.</p> <p>(b) Make sure return spring is attached to carriage.</p> <p>(c) Check Carriage Return Lever — Latch Clearance adjustment in Section 574-422-700TC.</p> |

TABLE 4

TROUBLESHOOTING — OFF-LINE OPERATION (Continued)

| NO. | SYMPTOM | ANALYSIS AND CORRECTIVE MEASURES |
|-----|-----------------------------------------------------------|----------------------------------------------------------------------------------------------------------------------------------------------------------------------------------------------------------------------------------------------------------------------------------------------------------------------------------------------------------------------------------------------------------------------------------------------------------------------------------------|
| 37 | No carriage return when LOCAL RETURN button is depressed. | Check Local Return adjustment in Section 574-426-700TC. |
| 38 | Spacing failure or erratic spacing. | <p>(a) Move carriage from left to right and make sure carriage rollers rotate freely.</p> <p>(b) If spacing fails and spacing feed pawl is not blocked, check following adjustments in Section 574-422-700TC:</p> <p style="padding-left: 40px;">Carriage Return Lever — Unlatch Clearance Feed Pawl Stop Position Feed Pawl Travel Carriage Return Lever Spring Space Suppression Lever Clearance — Printing Space Suppression Lever Clearance — Spacing</p> |
| 39 | Incorrect or erratic positioning at left margin. | <p>(a) Check for dashpot misalignment, binding of carriage rollers, or binding of plunger against dashpot surfaces.</p> <p>(b) Check Carriage Bounce and Carriage Return Lever — Unlatch Clearance adjustments in Section 574-422-700TC.</p> |
| 40 | Incorrect or erratic operation at right margin. | Check Line Length Selection adjustment in Section 574-422-700TC. |
| 41 | Signal bell fails to ring. | <p>(a) If bell fails to ring when bell code is keyed, check selection of function pawl in slot 7. Also check Bell Clapper Gap adjustment in Section 574-422-700TC.</p> <p>(b) If bell fails to ring when carriage approaches right margin, check selection of function pawl in slot F. Also check Margin Bell Bellcrank Clearance adjustment in Section 574-422-700TC.</p> |
| 42 | Spacing and printing suppression failures. | <p>(a) If unit neither prints nor spaces, and print hammer bail and spacing feed pawl are blocked, check Print Suppression Latch — Vertical Clearance adjustment in Section 574-422-700TC.</p> <p>(b) If unit fails to space on characters only, check Space Suppression Lever Clearance — Printing adjustment in Section 574-422-700TC.</p> |

TABLE 4

TROUBLESHOOTING — OFF-LINE OPERATION (Continued)

| NO. | SYMPTOM | ANALYSIS AND CORRECTIVE MEASURES |
|--------------------|---------------------------------------------------------------------------------------------------|--------------------------------------------------------------------------------------------------------------------------------------------------------------------------------------------------------------------------------------------------------------------------------------------------------------------------------------------------------------------------------------------------------------------------------------------------------------------------------------------------------------------------------------------------------------------------------------------------------------------------------------------------------------------------------------------------------------------------------------------------------------------------|
| 42 (contd) | | <p>(c) If unit fails to space on space only, check Space Suppression Latch Clearance — Spacing adjustment in Section 574-422-700TC.</p> <p>(d) If unit fails to print only, check Print Suppression Latchlever Release adjustment in Section 574-422-700TC.</p> <p>(e) If unit fails to suppress on nonprint, nonspace functions, check selection of correct function lever or blank function lever in slot 6. (See trouble No. 4 for function lever failures.)</p> <p>(f) If only print suppression fails, check Print Suppression Latchlever Release adjustment in Section 574-422-700TC.</p> <p>(g) If only space suppression fails, check Space Suppression Lever Clearance — Printing and Space Suppression Lever Clearance — Spacing in Section 574-422-700TC.</p> |
| 43 | ALARM does not light when low paper (friction feed) or no paper (sprocket feed) condition occurs. | <p>(a) Make sure paper is installed correctly.</p> <p>(b) Operate paper alarm lever manually and observe contacts.</p> <p>(c) Check circuitry related to paper alarm contacts in wiring diagrams 1194SD (DC/EIA interface) or 1196SD (FSK interface). If contacts and circuit connections are in good order, circuit card 303847 (DC/EIA) or 322491 (FSK) may be defective.</p> |
| ANSWER-BACK | | |
| 44 | Answer-back does not operate when HERE IS button is depressed. | <p>(a) Manually depress answer-back armature. If answer-back does not cycle, check the following adjustments in Section 574-422-700TC:</p> <p style="padding-left: 40px;">Trip Lever Clearance Trip Bail Position Trip Lever Overtravel and Armature Gap HERE IS Bellcrank Position</p> <p>(b) Refer to Figure 10 for electrical check points.</p> <p>(c) Connect a jumper between J20, pins 1 and 2 (DC/EIA interface) or between J4, pin 4 and ground (FSK interface). If answer-back cycles, HERE IS switch contacts may be defective.</p> |

TABLE 4

TROUBLESHOOTING — OFF-LINE OPERATION (Continued)

| NO. | SYMPTOM | ANALYSIS AND CORRECTIVE MEASURES |
|-------------------|-----------------------------------------------------------------------------------------------------------|-------------------------------------------------------------------------------------------------------------------------------------------------------------------------------------------------------------------------------------------------------------------------------------------------------------------------------------------------------------------------------------------------------------------------------------------------|
| 44 (contd) | | <p><u>DC/EIA Interface</u></p> <p>(d) With jumper between J20, pins 1 and 2, check voltage at J4, pin 6. If +24 v is present, form-out contact may be open. If not present, answer-back magnet coil may be defective.</p> <p><u>FSK Interface</u></p> <p>(e) With jumper from J4, pin 4 to ground, check voltage at J8, pin 8. If +24 v is present, answer-back magnet coil may be defective. If not present, form-out contact may be open.</p> |
| 45 | Answer-back drum moves during first distributor cycle but fails to continue cycle, or cycles erratically. | <p>Check following adjustments in Section 574-422-700TC:</p> <p style="padding-left: 40px;">Drum Position Feed Lever Position Feed Pawl Position</p> |
| 46 | Answer-back cycles but characters are not generated. | Check Character Suppression Contact Wire Gap adjustment in Section 574-422-700TC. |
| 47 | Incorrect characters produced by answer-back. Keyboard produces correct characters. | <p>(a) Check positioning of answer-back contact wires and springs.</p> <p>(b) Check Code Contact Wire Gap adjustment in Section 574-422-700TC.</p> |
| 48 | Answer-back repeats. | Check Trip Lever Clearance adjustment in Section 574-422-700TC. |
| TAPE PUNCH | | |
| 49 | Tape punch does not operate when lever is placed in ON position. | <p>(a) Check mechanical drive linkage between typing unit and punch. Operate typing unit manually with punch lever in ON position and observe action of drive linkage.</p> <p>(b) Check Tape Punch Drive adjustment in Section 574-425-700TC.</p> |
| 50 | Punched characters do not correspond to characters selected by keyboard and printed by typing unit. | <p>(a) Check for missing pawl springs.</p> <p>(b) Check following adjustments in Section 574-425-700TC:</p> <p style="padding-left: 40px;">Pawl Upstop Assembly — Final Stripper Bail Upstop Punch Penetration</p> |

TABLE 4

TROUBLESHOOTING — OFF-LINE OPERATION (Continued)

| NO. | SYMPTOM | ANALYSIS AND CORRECTIVE MEASURES |
|--------------------|------------------------------------------------------------------------------------------------------------------|--------------------------------------------------------------------------------------------------------------------------------------------------------------------------------------------------------------------------------------------------------------------------------------------------------------------------------------------------------------------------------------------------------------------------------------------------------------------------------------|
| 51 | Tape does not feed, or feeds erratically. | <ul style="list-style-type: none"> (a) Make sure tape roll is installed correctly, and tape feeds from top of roll. (b) Check for jammed tape or chad accumulation in punch block. (c) Check Punch Penetration and Feed Wheel Ratchet and Pawl adjustments in Section 574-425-700TC. |
| 52 | Tape does not backspace when lever is moved to B.SP. position. | Check Backspace Stop adjustment in Section 574-425-700TC. |
| 53 | Punch does not turn on when CONTRL DC2 is depressed on keyboard. | Check Automatic On adjustment in Section 574-425-700TC. |
| 54 | Perforations are spaced incorrectly. | Check Feed Wheel Ratchet and Pawl and 10 Characters Per Inch adjustments in Section 574-425-700TC. |
| 55 | Punch does not turn off when CONTRL DC4 is depressed on keyboard. | Check Automatic On adjustment in Section 574-425-700TC. |
| 56 | <p><u>Punch Equipped for Low Tape Alarm</u></p> <p>ALARM lamp does not light when low tape condition exists.</p> | <ul style="list-style-type: none"> (a) Check routing of tape between tape roll and punch. (b) If ALARM lamp responds to tape out/tight tape condition in reader, or low paper condition in typing unit, check low tape contacts of punch, and adjust as necessary. (c) Refer to wiring diagrams 1194SD (DC/EIA) or 1196SD (FSK) for electrical circuitry. |
| TAPE READER | | |
| 57 | Tape reader does not operate when lever is in START position. | <ul style="list-style-type: none"> (a) Manually depress armature of reader trip magnet. If reader operates, check start contact wire with lever in START position. Adjust per Section 574-424-700TC. (b) Make sure stop/tight tape/tape out contact wire is closed. If necessary, adjust per Section 574-424-700TC. <p><i>NOTE: For automatic readers, make sure EOT, DC3, and ENQ contacts are closed. (See Figure 12 (DC/EIA) or Figure 11 (FSK).)</i></p> |

TABLE 4

TROUBLESHOOTING — OFF-LINE OPERATION (Continued)

| NO. | SYMPTOM | ANALYSIS AND CORRECTIVE MEASURES |
|---------------|--------------------------------------------------------------------------------------------------------------------------------------------------------------------------------------|------------------------------------------------------------------------------------------------------------------------------------------------------------------------------------------------------------------------------------------------------------------------------------------------------------------------------------------------------------------------------------------------------------------------------------------------------------------------------------------------------------------------------------------------------------------------------------------------------------------------------|
| 57 (contd) | | <p>(c) Check for approximately 150 v dc between J1, pin 3 (+) and J1, pin 6 (-) with lever in START position. If not present, check for 115 v ac between J1, pins 14 and 15. If dc voltage is not present, but ac voltage is correct, replace fuse F3. If dc is still not present, reader circuit card 183079 may be defective.</p> <p>(d) If dc voltage is correct between J1, pins 3 and 6, check for approximately 150 v dc between J2, pin 13 (+) and J2, pin 1 (-). If voltage is present, reader feed magnet coil may be defective. If not, check continuity of circuit per Figure 12 (DC/EIA) or Figure 11 (FSK).</p> |
| 58 | Reader operates when lever is held in START position, but stops when lever is released. | <p>(a) Check operation of TDC relay on reader feed card 183079.</p> <p>(b) If TDC-2 contacts fail to close when lever is placed in START position, check for 24 v dc between J1, pin 8 (+) and J1, pin 13 (-). If present, TDC relay may be defective. If not present, check circuit connections per Figure 12 (DC/EIA) or Figure 11 (FSK).</p> |
| 59 | <p><u>Reader Strapped For Automatic Operation</u></p> <p>Reader does not start when DC1 is keyboarded. Operation normal when reader operating lever is placed in START position.</p> | <p>(a) Check for closure of DC1 function contacts on typing unit when CONTRL/DC1 is depressed.</p> <p>(b) If contact operation is normal, check circuit connections per Figure 12 (DC/EIA) or Figure 11 (FSK).</p> |
| 60 | Reader does not single-step when lever is moved to STEP position. Operation normal when lever is moved to START position. | <p>(a) Make sure contact closes when lever is moved to STEP position. Adjust as necessary.</p> <p>(b) Check circuit connections per Figure 12 (DC/EIA) or Figure 11 (FSK).</p> |
| 61 | Printed copy on typing unit does not correspond to code characters on tape when typing unit is operated from reader. Typing unit gives correct print out from keyboard. | <p>(a) Check for damaged or bent sensing contacts, or for contacts out of sensing pin slots.</p> <p>(b) Check following adjustments in Section 574-424-700TC:</p> <p style="padding-left: 40px;">Detent Lever Feed Pawl Sensing Pin</p> |

TABLE 4

TROUBLESHOOTING — OFF-LINE OPERATION (Continued)

| NO. | SYMPTOM | ANALYSIS AND CORRECTIVE MEASURES |
|-----|---------------------------------------------------------------------------------------------------------------|----------------------------------------------------------------------------------------------------------------------------------------------------------------------------------------------------------------------|
| 62 | Tape jams or tears when fed through reading head. | (a) Check tape lid and guide pins for burrs or roughness. (b) Check for binding of sensing pins. |
| 63 | Tape cannot be moved freely through head in both directions when control lever is in FREE position. | Make sure control lever extension engages blocking pawl and feed pawl when control lever is in FREE position. |
| 64 | Reader does not stop when control lever is moved to STOP position. | Make sure stop contact opens when lever is moved to STOP position. Adjust as necessary. |
| 65 | Reader does not stop when tape runs out or when tight tape condition occurs. | (a) Make sure tape out/tight tape contact opens for either condition. See Figure 12 (DC/EIA) or Figure 11 (FSK) for circuitry. (b) Check Control (or Tape-Out) Contact Wires adjustment in Section 574-424-700TC. |
| 66 | <u>Reader Strapped for Automatic Operation</u> Reader does not stop when DC3, ENQ, or EOT is read on tape. | Check for opening of function contacts on typing unit when CONTRL/DC3, ENQ, or EOT is depressed. See Figure 12 (DC/EIA) or Figure 11 (FSK) for circuitry. |

TABLE 5

TROUBLESHOOTING — ON-LINE OPERATION WITH DC OR EIA INTERFACE

NOTES:

Circuit common is terminal 8 or 9 of card 303846.

Signal currents in signal lines of DC interface are 60 or 20 ma from an external voltage source of 25 to 120 v dc.

Voltage levels for EIA interface are +5 to +25 v for "on" or "space" and -5 to -25 v for "off" or "mark."

| NO. | SYMPTOM | ANALYSIS AND CORRECTIVE MEASURES |
|-----|-------------------------------------------------------------------------------------------------------------------------|------------------------------------------------------------------------------------------------------------------------------------------------------------------------------------------------------------------------------------------------------------------------------------------------------------------------------------------------------------------------------------------------------------------------------------------------------------------------------------------------------------------------------------------------------------------------------------------------------------------------------------------------------------------------------------------------------------------------------------------------------|
| 1 | <p>Motor does not run when LINE or LINE FDX button is depressed. Motor does turn on when LOCAL button is depressed.</p> | <p><u>DC Interface</u></p> <p>(a) Check for positive voltage at J11, pin 6. If not present, check local, off, and paper alarm switch contacts per Figure 5.</p> <p>(b) If voltage is correct at J11, pin 6, check voltage at J15, pin 6. If voltage is not zero, circuit card 303847 may be defective.</p> <p><u>EIA Interface</u></p> <p>(a) Check for positive voltage at J11, pin 15. If not present, check EOT, local, off, and paper alarm contacts per Figure 6.</p> <p>(b) Check for positive voltage at J11, pin 6. If not present, trouble is external (no DSR signal from external device).</p> <p>(c) If voltage is correct at J11, pin 6, check voltage at J15, pin 6. If voltage is not zero, circuit card 303847 may be defective.</p> |
| 2 | <p>Local typing unit runs continuously (open) in line mode on either half-duplex or full-duplex operation.</p> | <p><u>DC Interface</u></p> <p>Check for small voltage between J11, pins 5 (+) and 9 (-). If not present, trouble is external.</p> <p>CAUTION: IF CIRCUIT IS OPEN, VOLTAGES UP TO +125 V MAY BE PRESENT.</p> <p>If voltage is normal, circuit card 303847 may be defective.</p> <p><u>EIA Interface</u></p> <p>Check voltage at J11, pin 3. If positive voltage (space) is present, trouble is external (ie, no marking carrier from external device). If negative voltage is present, circuit card 303847 may be defective.</p> |

TABLE 5

TROUBLESHOOTING — ON-LINE OPERATION WITH DC OR EIA INTERFACE (Continued)

| NO. | SYMPTOM | ANALYSIS AND CORRECTIVE MEASURES |
|-----|--------------------------------------------------------------------------------------------------------------------------|-------------------------------------------------------------------------------------------------------------------------------------------------------------------------------------------------------------------------------------------------------------------------------------------------------------------------------------------------------------------------------------------------------------------------------------------------------------------------------------------------------------------------------------------|
| 3 | <p><u>DC Interface Wired for Half-Duplex</u></p> <p>Local and remote terminals run continuously (open) in line mode.</p> | <p>Place jumper between J11, pins 5 and 10. If remote receiver still runs open, trouble is external. If not, remove jumper and check voltage between J11, pins 11 (+) and 10 (-), and between J11, pins 5 (+) and 9 (-). Each voltage should be about 2 v.</p> <p><i>CAUTION: IF CIRCUIT IS OPEN, VOLTAGES UP TO 125 V MAY BE PRESENT.</i></p> <p>If voltages are correct, circuit card 303847 may be defective.</p> |
| 4 | Remote terminal runs continuously (open) in line mode. | <p><u>DC Interface</u></p> <p>(a) If terminal is wired for half-duplex, trouble is external.</p> <p>(b) If wired for full-duplex, connect jumper between J11, pins 10 and 11. If remote terminal still runs open, trouble is external. If not, circuit card 303847 may be defective.</p> <p><u>EIA Interface</u></p> <p>(a) Check voltage at J11, pin 11. If negative (marking) and if J11, pin 4 is positive (RTS on), trouble is external.</p> <p>(b) If voltage at J11, pin 11 is not -24 v, circuit card 303847 may be defective.</p> |
| 5 | Remote terminal does not receive message from local terminal in line mode. | <p>(a) Check voltage at J13, pin 2. If +20 v, check to make sure normally closed contacts of LINE or LINE FDX are open. If not, switch may be defective.</p> <p>(b) Voltage at J13, pin 2 should be zero with no message being sent. If not, circuit card 303847 may be defective.</p> |
| 6 | Local terminal does not receive message from remote terminal in line mode. | <p><u>DC Interface</u></p> <p>(a) Place jumper between J11, pins 5 and 9. If local typing unit runs open, trouble is external.</p> <p>(b) Check voltage at J13, pin 6. If voltage is zero, local contact may be closed in line mode. Check and repair as necessary. If positive voltage is present, circuit card 303847 may be defective.</p> |

TABLE 5

TROUBLESHOOTING — ON-LINE OPERATION WITH DC OR EIA INTERFACE (Continued)

| NO. | SYMPTOM | ANALYSIS AND CORRECTIVE MEASURES |
|--------------|-----------------------------------------------------------------------------------------------------------------------|--------------------------------------------------------------------------------------------------------------------------------------------------------------------------------------------------------------------------------------------------------------------------------------------------------------------------------------------------------------------------------------------------------------------------------------|
| 6 (contd) | | <p><u>EIA Interface</u></p> <p>(a) Check voltage at J11, pin 3. If pulsating voltage (+ and -) is not present when signal is being transmitted from remote terminal, trouble is external.</p> <p>(b) Check voltage at J13, pin 6. If voltage is zero, local contact may be closed in line mode. Check and repair as necessary. If positive voltage is present, circuit card 303847 may be defective.</p> |
| 7 | <p><u>Full-Duplex Option Enabled</u></p> <p>Local typing unit operates when local terminal transmits in LINE FDX.</p> | <p>Check for +24 v at J15, pin 11. If not present, check contacts on LINE FDX switch. If present, circuit card 303847 may be defective.</p> |
| 8 | <p>Copy errors in line mode. No errors noted in local mode.</p> | <p>Check range scale setting on typing unit. Adjust as necessary to provide error-free copy.</p> |
| 9 | <p>Answer-back does not operate when ENQ is received from remote terminal.</p> | <p>(a) Place terminal in local mode.</p> <p>(b) Depress CONTRL/ENQ and manually trip codebar clutch. If ENQ function pawls operate (extreme right of function box), check Right Rocker Drive adjustment in Section 574-422-700TC.</p> <p>(c) If function pawls do not operate, depress OFF button, trip codebar clutch, and manually cycle main shaft clockwise as viewed from left. Check for binds in function lever or pawls.</p> |

TABLE 6

TROUBLESHOOTING — ON-LINE WITH FSK INTERFACE

NOTES:

Circuit common is J14, pin 15.

Voltage low is zero to +1 v.

Voltage high is +2 to +6 v.

| NO. | SYMPTOM | ANALYSIS AND CORRECTIVE MEASURES |
|-----|------------------------------------------------------------------------------------------------------------------------------------------------------------------------------------------------|--------------------------------------------------------------------------------------------------------------------------------------------------------------------------------------------------------------------------------------------------------------------------------------------------------------------------------------------------------------------------------------------------------------------------------------------------------------------------------------------------------------------------------------------------------------------------------------------------------------------------------------------------------------------------|
| 1 | Motor does not run when ANS or ORIG button is depressed. No dial tone on auto-answer DAA. | <p>(a) Measure voltage at J15, pin 9 and depress ANS button. Voltage should be +6 v when button is depressed, and zero when released.</p> <p>(b) Measure voltage at J15, pin 7 and depress ORIG button. Voltage should be zero when button is depressed, and +6 v when released.</p> <p>(c) Measure voltage at J15, pins 3 and 5 within 25 seconds after depressing ANS or ORIG button. Voltage at pin 3 should be +6 v, and voltage at pin 5 should be zero.</p> <p>(d) If above voltages are correct, circuit card 322491 may be defective. If any are incorrect, check ANS, ORIG, EOT, CLEAR, LOCAL, or PAPER ALARM contacts. See Figure 9 for related circuitry.</p> |
| 2 | <p><u>Auto-Answer DAA</u></p> <p>Motor does not run when ANS or ORIG button is depressed. Dial tone is present in DAA.</p> | Circuit card 322491 may be defective. |
| 3 | Motor turns on when ORIG button is depressed, but ORIG lamp does not light after hanging up handset (auto-answer DAA) or lifting exclusion key (manual DAA). Motor turns off after 25 seconds. | <p>(a) F2m carrier (2225 Hz tone) from remote terminal may be too weak to operate circuit. If so, trouble is external. Check loudness of tone in handset.</p> <p>(b) If f2m tone seems adequate, originate call and check voltage at J2, pin 8 after going on line (within 25 seconds after remote terminal goes into answer mode). If voltage is zero, circuit card 322490 may be defective. If voltage is +6 v, circuit card 322491 may be defective.</p> |
| 4 | When answering a call, motor turns on but ANS lamp does not light. Motor turns off after 25 seconds. In terminal equipped for auto answer-back in called mode, answer-back is not sent. | <p>(a) F1m carrier (1270 Hz tone) may not be received from remote terminal. Check voltage at J2, pin 8. If voltage is zero during 25 second interval, trouble is due to lack of incoming f2m carrier. If voltage is high, circuit card 322491 may be defective.</p> |

TABLE 6

TROUBLESHOOTING — ON-LINE WITH FSK INTERFACE (Continued)

| NO. | SYMPTOM | ANALYSIS AND CORRECTIVE MEASURES |
|--------------|-------------------------------------------------------------------------------------------------------------------------------------------------------------------------------------------------------------------------|------------------------------------------------------------------------------------------------------------------------------------------------------------------------------------------------------------------------------------------------------------------------------------------------------------------------------------------------------------------------------------------------------------------------------------------------------------------------------------------------------------------------------------------------------------------------------------------------------------------------------------------------------------------------------------------------------------------------------------|
| 4 (contd) | | (b) F2m carrier (2225 Hz tone) may not have been sent to remote terminal. Check with remote operator. If f2m carrier is not produced, check for zero voltage at J2, pins 4 and 13. If voltage is zero yet tone is not produced, readjust R32. If still not produced, circuit card 322490 may be defective. If voltage at J2, pins 4 and 13 is not zero, circuit card 322491 may be defective. |
| 5 | When placing a call, ORIG lamp lights but no answer-back is received from remote terminal equipped for auto answer-back. ORIG lamp goes out and motor stops after 25 seconds. If auto-answer DAA, terminal disconnects. | F1m carrier may not have been sent, or f1m level may be too low. While ORIG lamp is on, check for f1m carrier. If present, trouble is external. If not present, check voltages at J2, pins 7 and 13. If either voltage is zero, circuit card 322491 may be defective. If both voltages are high, circuit card 322490 may be defective. |
| 6 | ORIG or ANS lamp lights and remains on, but typing unit runs open or does not print message from remote terminal. | <p>(a) Check voltage at J2, pin 14 for constant high (spacing) or constant low (marking) when remote terminal is transmitting.</p> <p>(b) If voltage at J2, pin 14 varies with incoming message, circuit card 322491 may be defective.</p> <p>(c) If voltage at J2, pin 14 does not vary with incoming message, check operation in both originate and answer mode. If operation fails in both modes, go into echoplex mode.</p> <p>(d) If remote sender (in full-duplex) receives looped back message, circuit card 322491 of local terminal may be defective.</p> <p>(e) If remote sender does not receive looped back message, monitor data line with test handset to determine if data signals are present (see Figure 16).</p> |
| 7 | ORIG or ANS lamp lights and remains on, but remote terminal runs open or does not print message sent by local terminal. | <p>(a) Check voltage at J2, pin 1 for constant high (space) or constant low (mark) when local terminal is transmitting.</p> <p>(b) If voltage at J2, pin 1 remains constant, circuit card 322491 may be defective. Refer to Figure 16 for related circuits.</p> <p>(c) If voltage at J2, pin 1 varies with message, monitor data line with test handset to determine if data signals are being sent. Refer to Figure 16 for circuitry.</p> <p>(d) If data signals are not present, circuit card 322490 may be defective.</p> |

TABLE 6

TROUBLESHOOTING — ON-LINE WITH FSK INTERFACE (Continued)

| NO. | SYMPTOM | ANALYSIS AND CORRECTIVE MEASURES |
|-----|--------------------------------------------------------------------------------------------------------------------------------------------------------------|----------------------------------------------------------------------------------------------------------------------------------------------------------------------------------------------------------------------------------------------------------------------------------------------------------------------------------------------------------------------------------------|
| 8 | Local terminal sends and receives correctly, but fails to echo in originate or answer mode when echoplex function is implemented. | Circuit card 322491 may be defective. |
| 9 | Terminal fails to disconnect when no carrier is present for approximately 25 seconds. | Check voltage at J2, pin 8. If high, circuit card 322490 may be defective. If low, circuit card 322491 may be defective. |
| 10 | ANS lamp does not flash in response to incoming ring signal when auto-answer terminal is called in local mode. | Check for low pulsing at J16, pin 11 when ringing. If pulsing occurs at J16, pin 11, but voltage remains high at J15, pin 8, circuit card 322491 may be defective. |
| 11 | Motor does not turn off on receipt of EOT or loss of carrier. | Circuit card 322491 may be defective. Refer to Figures 9 and 14 for control and reset circuitry. |
| 12 | Motor turns off but terminal fails to disconnect on receipt of EOT or loss of carrier. Terminal does not disconnect when CLEAR or LOCAL button is depressed. | Check voltage at J15, pin 3. If low, circuit card 322491 may be defective. If high, trouble is probably in DAA. If trouble occurs on only one of the listed conditions, refer to Figures 9 and 14 and check contact and reset circuitry. |
| 13 | Local typing unit prints out locally generated message in full-duplex. | Check voltage at J15, pin 12. If low, circuit card 322491 may be defective. |
| 14 | In echoplex mode, local terminal fails to inhibit sending (option screw no. 1 tight). | Check voltage at J15, pin 11. If high, circuit card 322491 may be defective. If low, check echo contacts. See Figure 18 for related circuitry. |
| 15 | Local terminal goes into answer mode when called, but does not produce answer-back (option screw no. 4 tight). | Circuit card 322491 may be defective. Refer to Figure 14 for related circuitry. |
| 16 | Answer-back does not operate when ENQ is received from remote terminal. | Place terminal in local mode and depress CONTRL ENQ on keyboard. Manually trip codebar clutch. If ENQ function pawls operate (extreme right of function box), check Right Rocker Drive adjustment of Section 574-422-700TC. If not, depress CLEAR button, trip codebar clutch, and manually cycle main shaft clockwise as viewed from left. Check for binds in function lever or pawl. |

| | | | | | | | | | | | | | | | |
|------|---|---|---|-----|-----|-----|----|---|---|---|---|-----|--|--|--|
| | | | | 7 | 0 | | | | 1 | | | | | | |
| BITS | | | | 6 | 0 | | 1 | | 0 | | 1 | | | | |
| | | | | 5 | 0 | 1 | 0 | 1 | 0 | 1 | 0 | 1 | | | |
| 4 | 3 | 2 | 1 | | | | | | | | | | | | |
| 0 | 0 | 0 | 0 | NUL | DLE | SP | 0 | @ | P | \ | p | | | | |
| | | 0 | 1 | SOH | DC1 | ! | 1 | A | Q | a | q | | | | |
| | | 1 | 0 | STX | DC2 | " | 2 | B | R | b | r | | | | |
| | | 1 | 1 | ETX | DC3 | # | 3 | C | S | c | s | | | | |
| | 1 | 0 | 0 | 0 | EOT | DC4 | \$ | 4 | D | T | d | t | | | |
| | | | 0 | 1 | ENQ | NAK | % | 5 | E | U | e | u | | | |
| | | 1 | 0 | 0 | ACK | SYN | & | 6 | F | V | f | v | | | |
| | | | 1 | 1 | BEL | ETB | ' | 7 | G | W | g | w | | | |
| 1 | 0 | 0 | 0 | BS | CAN | (| 8 | H | X | h | x | | | | |
| | | 0 | 1 | HT | EM |) | 9 | I | Y | i | y | | | | |
| | | 1 | 0 | LF | SUB | * | : | J | Z | j | z | | | | |
| | | 1 | 1 | VT | ESC | + | ; | K | [| k | { | | | | |
| | 1 | 0 | 0 | 0 | FF | FS | , | < | L | \ | l | | | | |
| | | | 0 | 1 | CR | GS | - | = | M |] | m | } | | | |
| | | 1 | 0 | 0 | SO | RS | . | > | N | ^ | n | ~ | | | |
| | | | 1 | 1 | SI | US | / | ? | O | _ | o | DEL | | | |

Characters and controls are generated by use of a key alone (), with a SHIFT key (), or with a CONTRL key ().

Figure 1 - American National Standard Code for Information Interchange (ASCII)

| | | | | | | | | | | | | | | | |
|-----------------|---|-----|-----|---|---|---|--------|------------------------|---|--------------|-------------|--------------|------------|---|--------|
| | & | % | \$ | # | " | ! | A D | (|) | * | + | , | - | . | / |
| BELL | | WRU | EOT | | | | SPACE | BACK SPACE | | LINE FEED | VERT TAB | FORM FEED | CAR RET | | |
| 7 | 6 | 5 | 4 | 3 | 2 | 1 | 0 | 8 | 9 | : | ; | < | = | > | ? |
| G | F | E | D | C | B | A | @ | H | I | J | K | L | M | N | O |
| W | V | U | T | S | R | Q | P | X | Y | Z | [| \ |] | ^ | _ |
| g | f | e | d | c | b | a | ` | h | i | j | k | l | m | n | o |
| w | v | u | t | s | r | q | p | x | y | z | { | | } | ~ | DELETE |
| CLOCKWISE FIELD | | | | | | | | COUNTERCLOCKWISE FIELD | | | | | | | |

Figure 2 - Type Wheel Layout for 38 Typing Unit

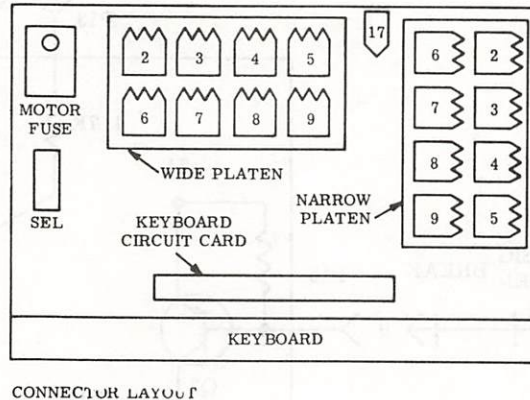
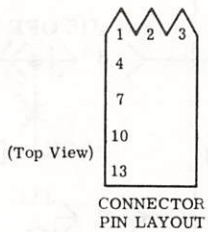

Figure 3 - Connector Layout on Base of Typing Unit

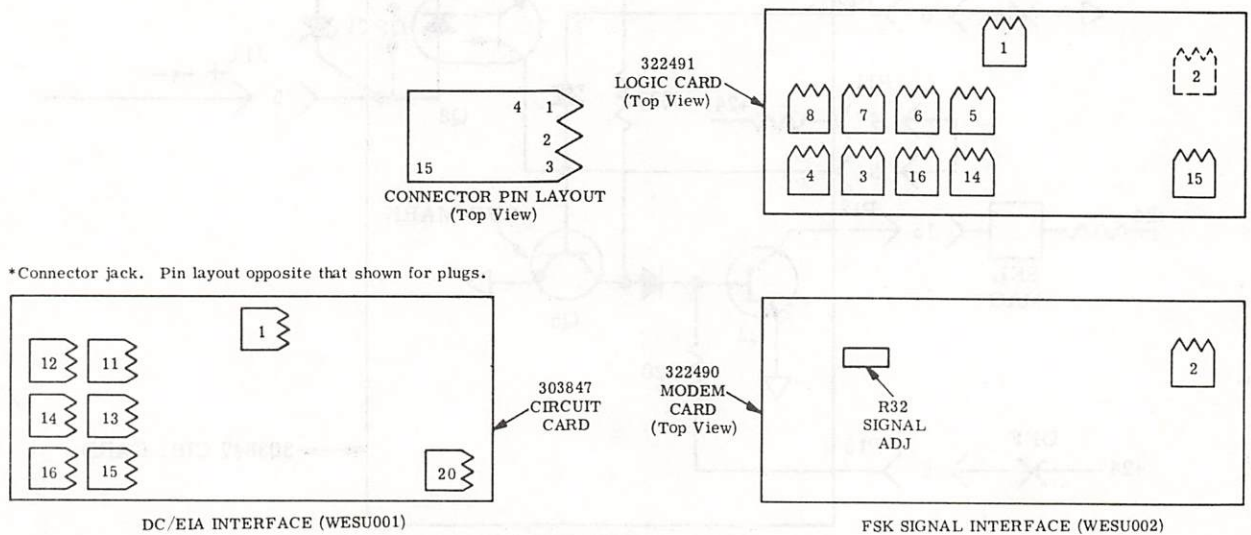

Figure 4 - Connector Layout on ESU

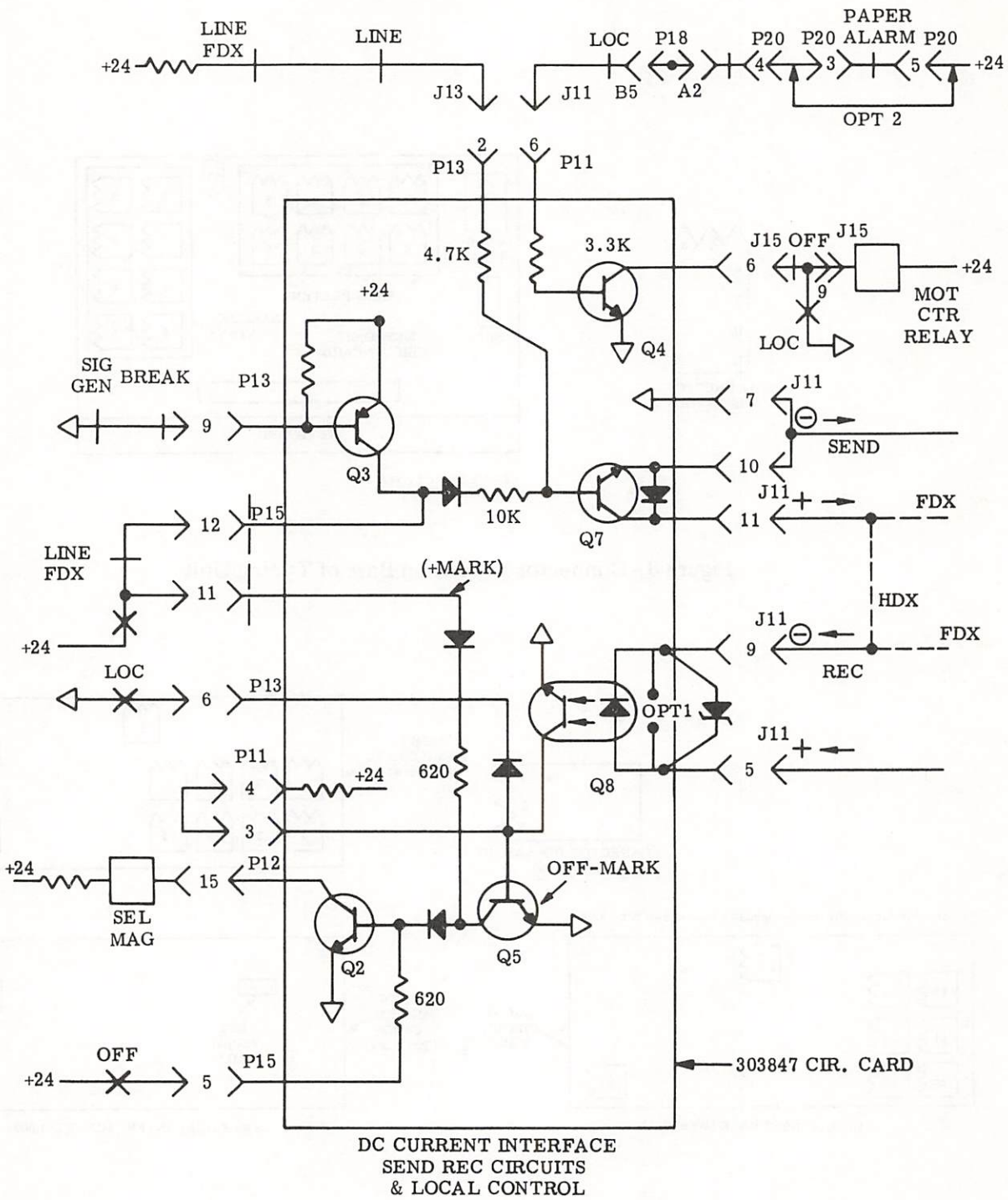
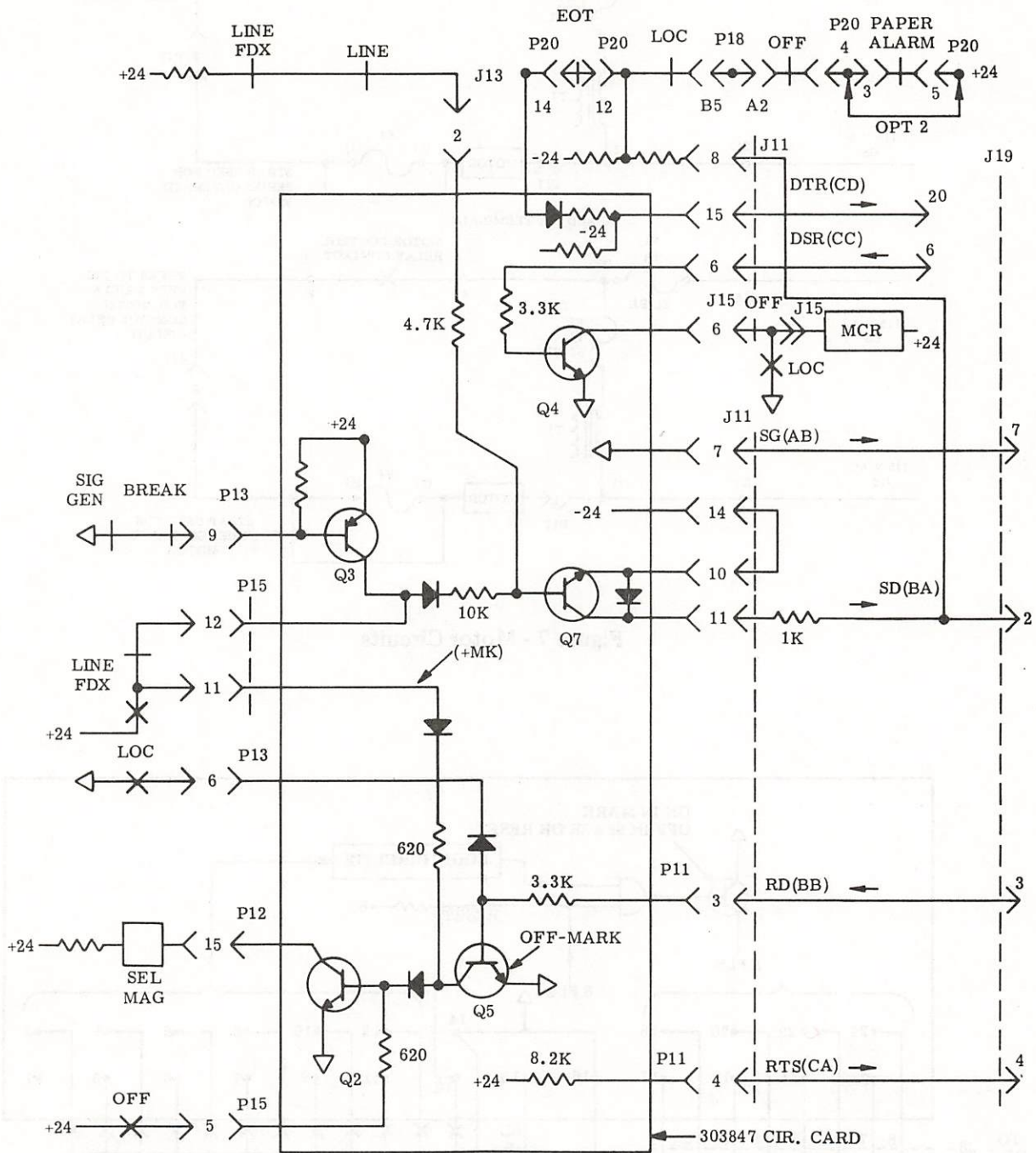

Figure 5 - DC Interface Send/Receive and Local Control Circuits



DC EIA INTERFACE
SEND REC & LOCAL CONTROL CIRCUITS

Figure 6 - EIA Interface Send/Receive and Local Control Circuits

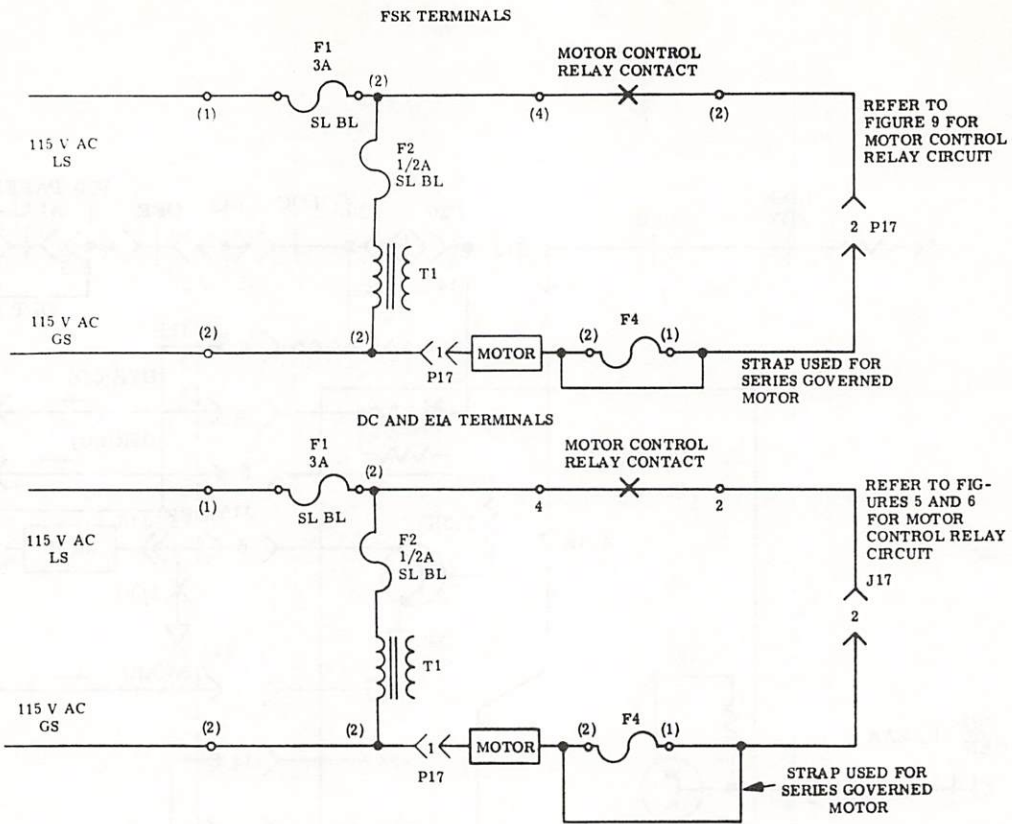

Figure 7 - Motor Circuits

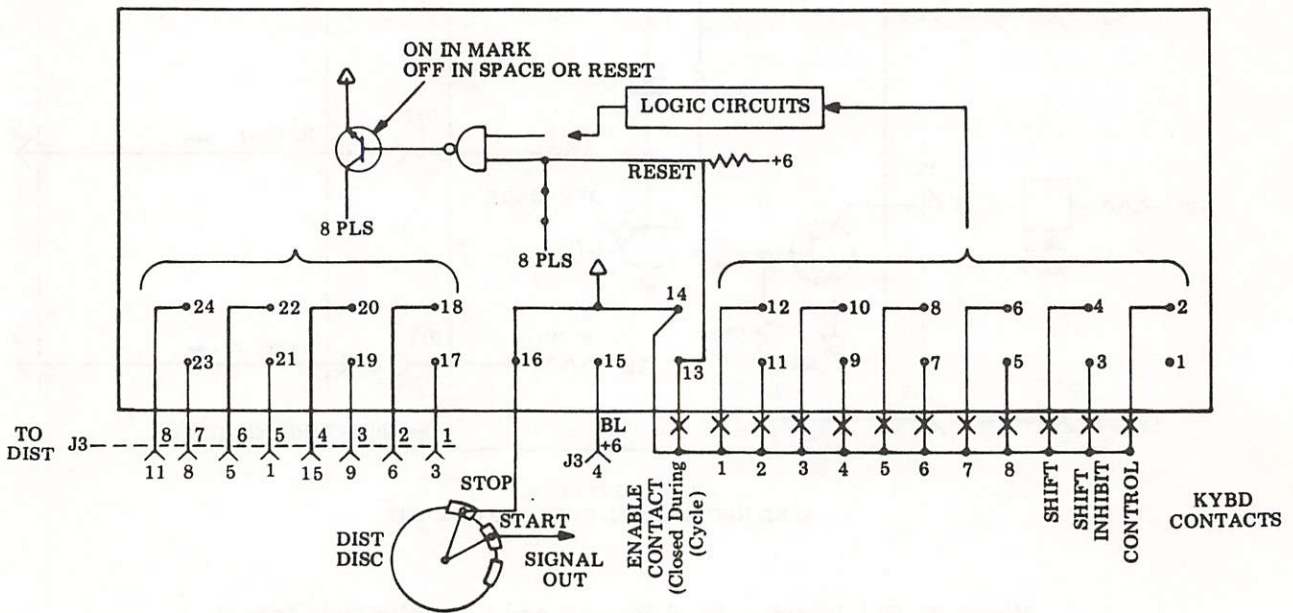

Figure 8 - Keyboard Logic Card

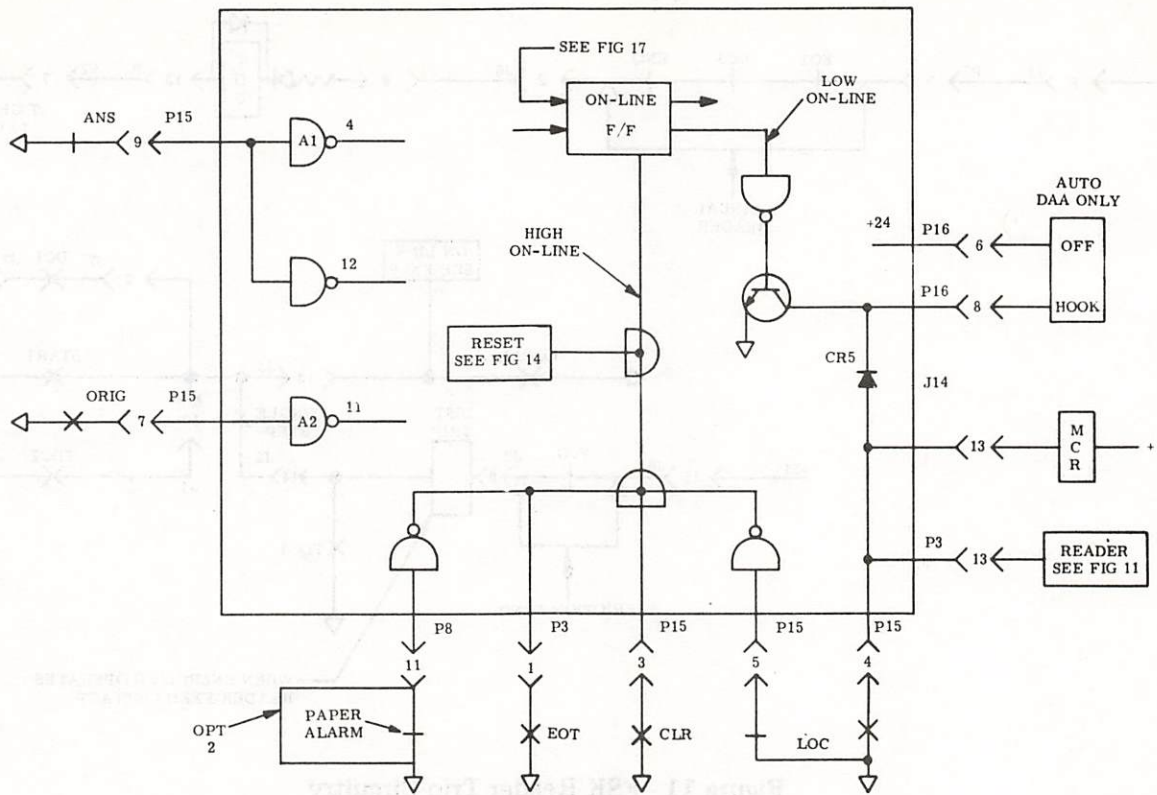

Figure 9 - FSK Motor - Off-Hook Circuits

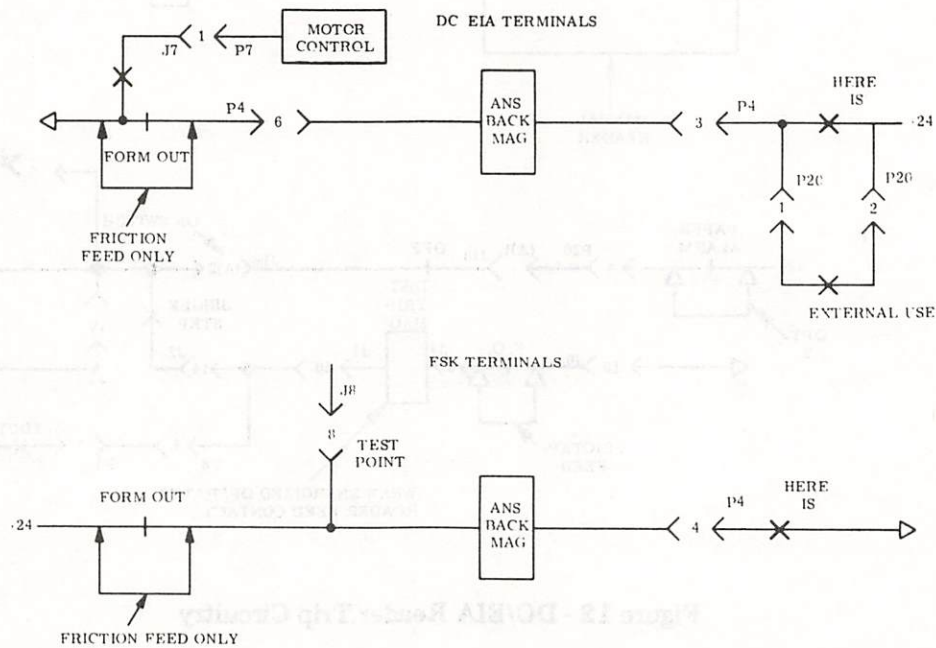

Figure 10 - Local Answer-Back Control

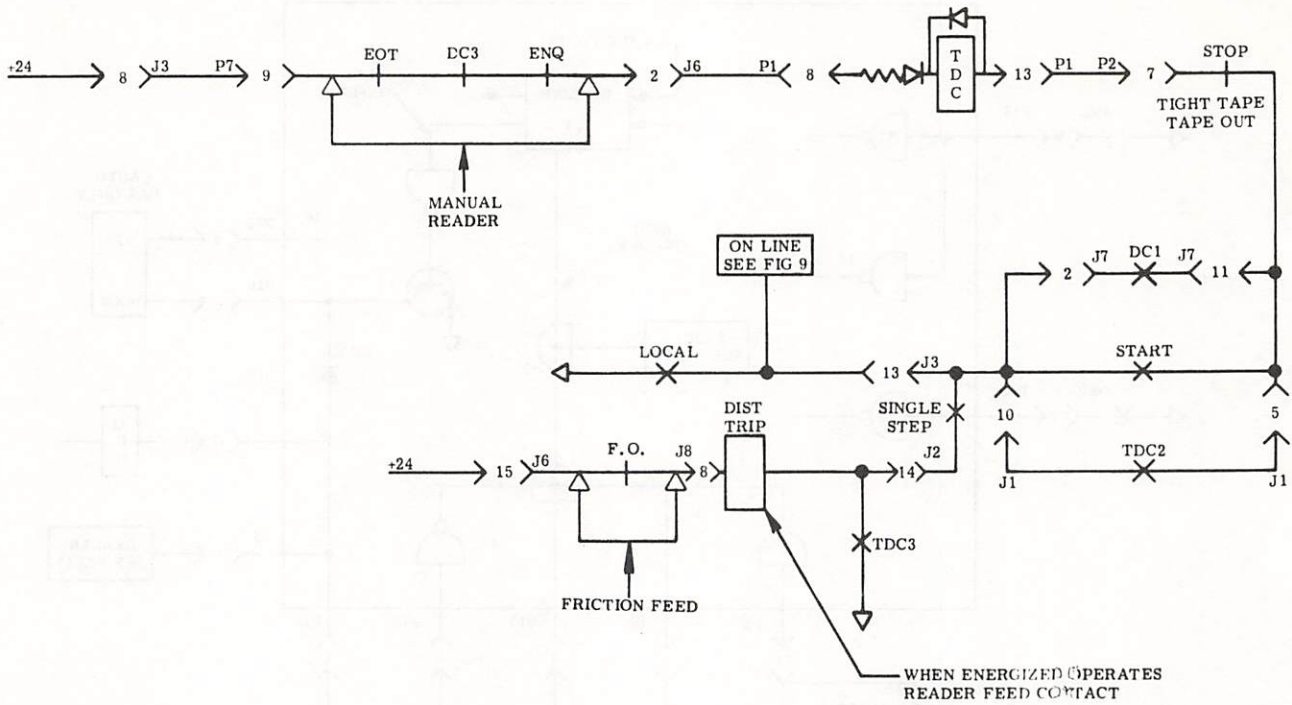

Figure 11 - FSK Reader Trip Circuitry

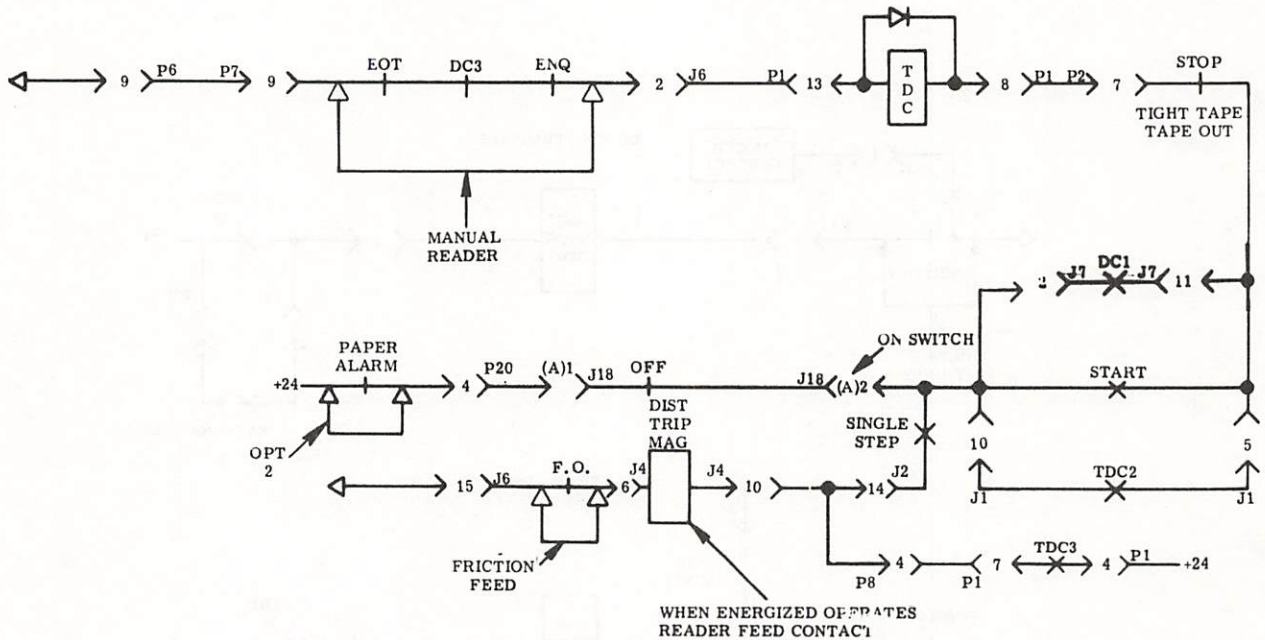
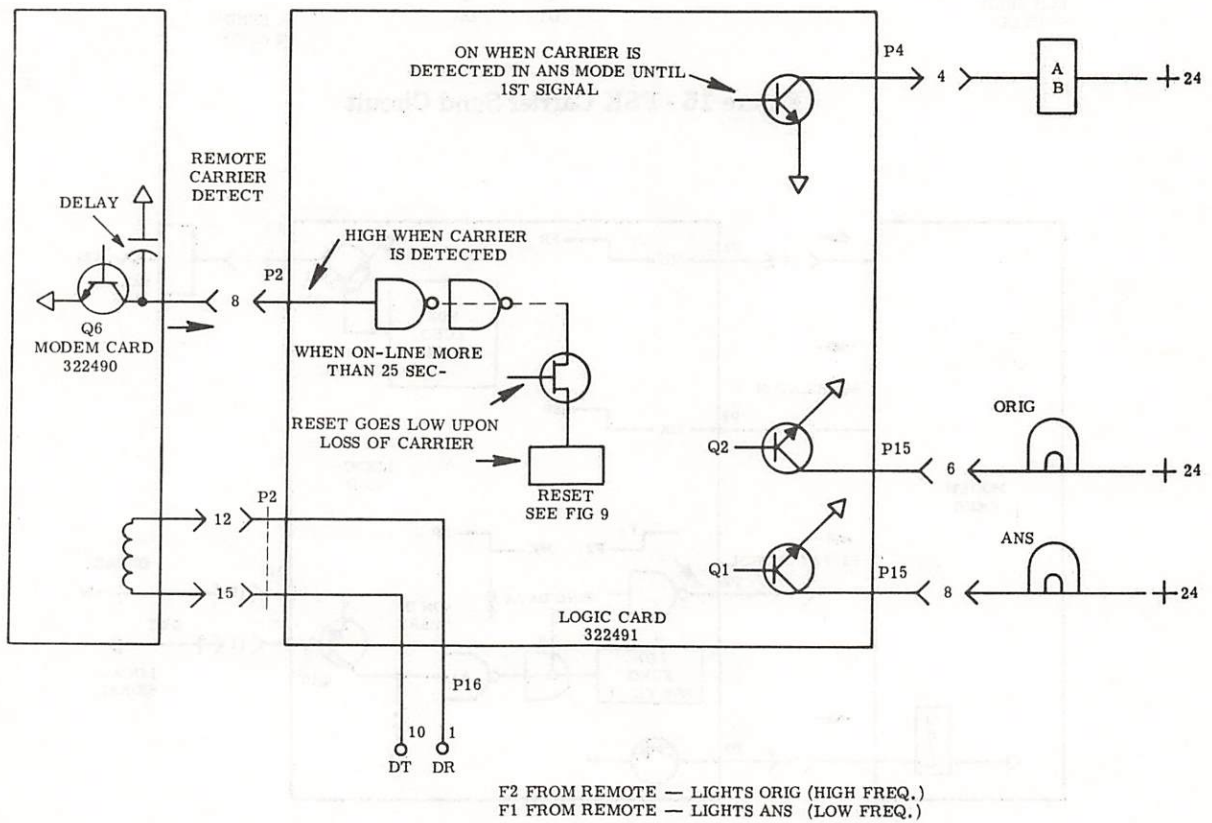
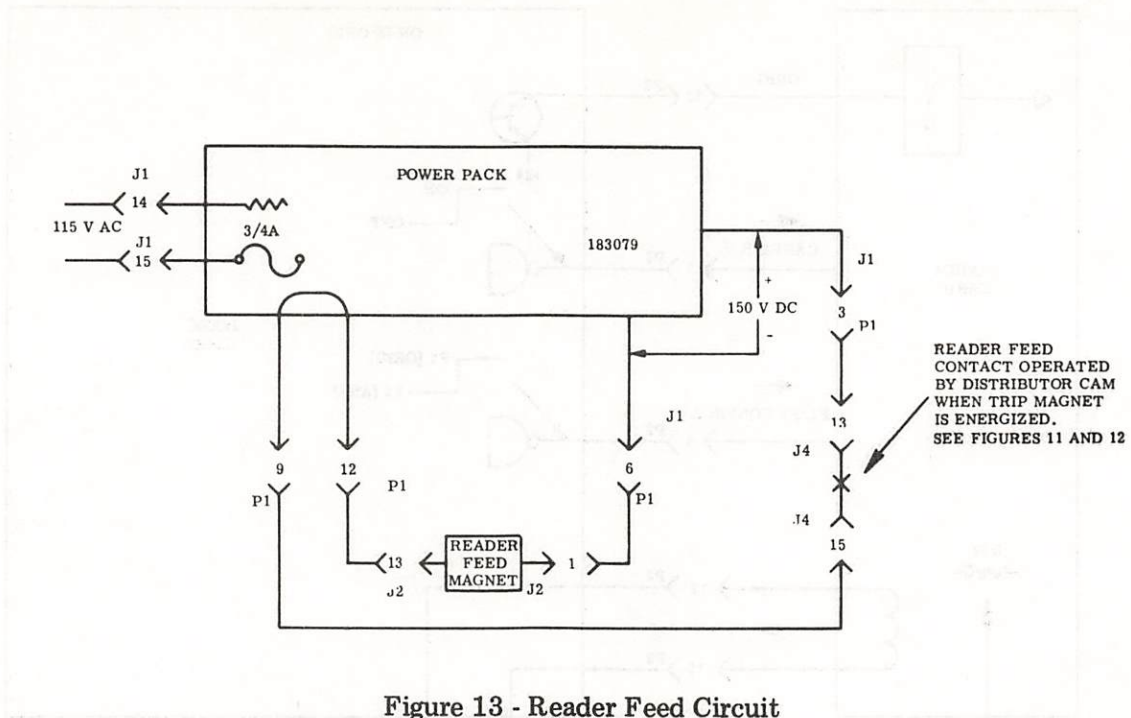

Figure 12 - DC/EIA Reader Trip Circuitry



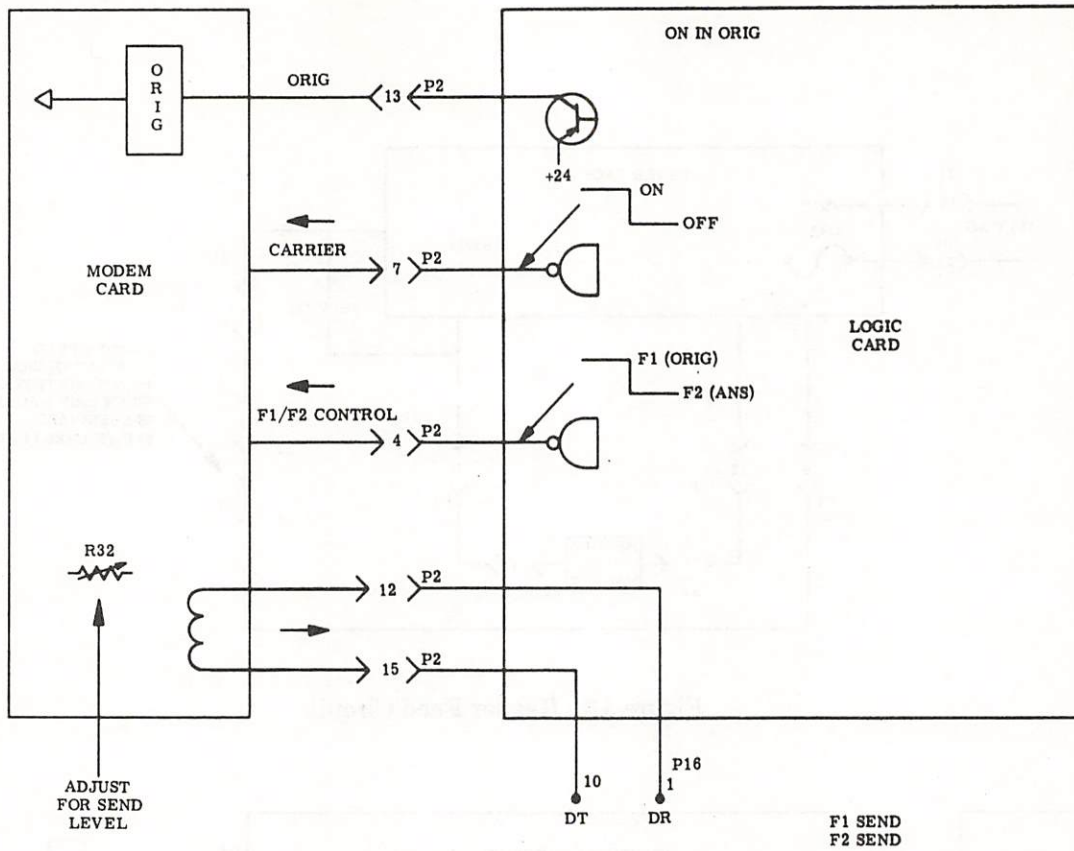

Figure 15 - FSK Carrier Send Circuit

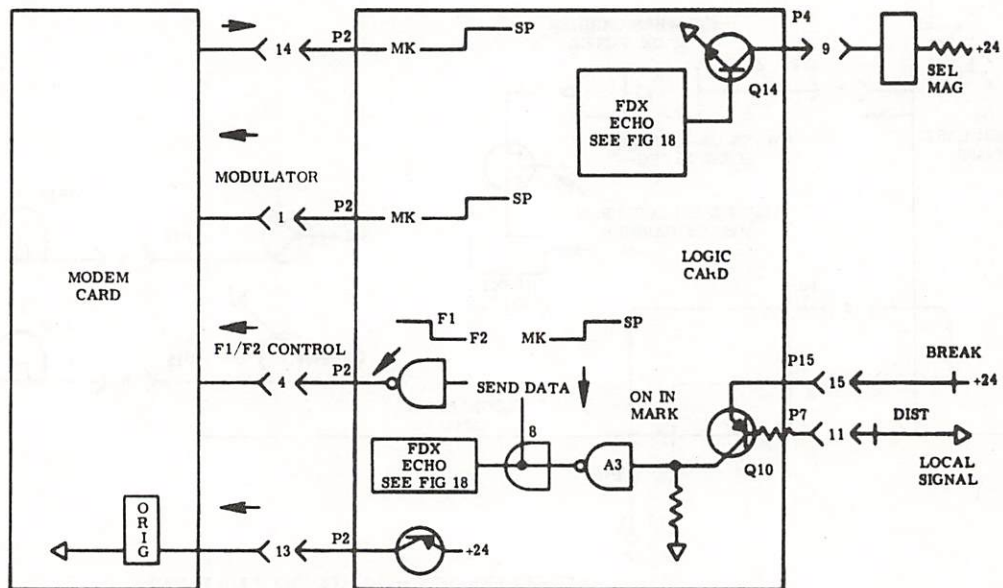

Figure 16 - FSK Carrier Modulate/Demodulate Circuit

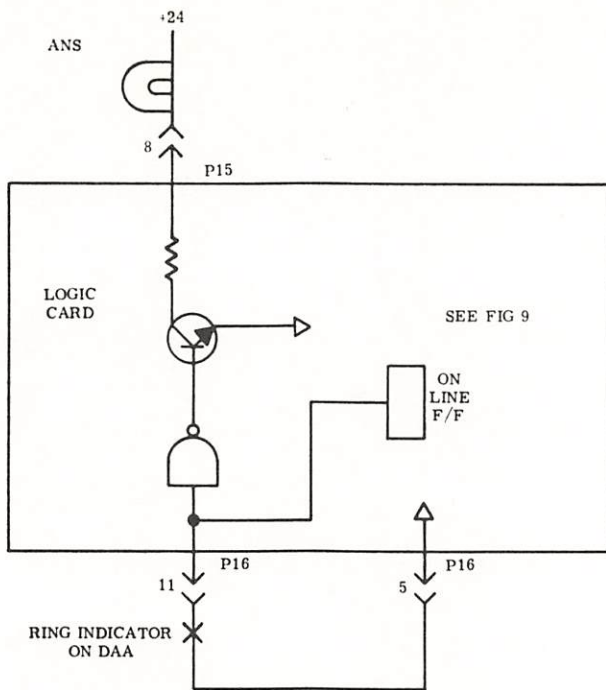

Figure 17 - Ring Indicator Circuit

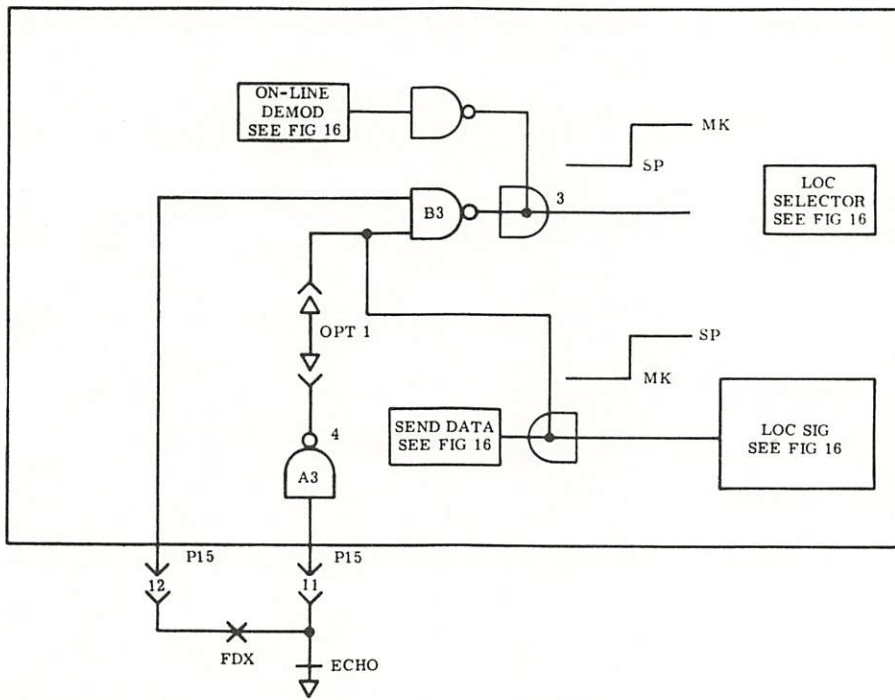

Figure 18 - FDX/Echo Control Circuit

38 ASR TELETYPEWRITER

REMOVAL AND REPLACEMENT OF COMPONENTS

| CONTENTS | PAGE | |
|----------------------------------------------------|------|---------------------------------------------------------------------------------------------------------------|
| 1. GENERAL | 1 | (b) Disconnect ground strap from ground terminal at left rear of base pan. |
| 2. REMOVAL AND REPLACEMENT OF COMPONENTS | 1 | (c) Unhook top of spring from stop arm. |
| COVER | 1 | (d) Remove screw, washer, and spacer from top of stop arm. |
| KEYBOARD HOOD | 1 | (e) Rotate cover about 100 degrees, slide it to right until it is clear of its hinges, and then remove cover. |
| KEYBOARD | 1 | 2.02 Replace cover by reversing procedure in 2.01. |
| PRINTER | 2 | KEYBOARD HOOD |
| ELECTRICAL SERVICE UNIT | 4 | 2.03 Remove keyboard hood (Figure 2) as follows: |
| READER | 6 | (a) Pivot cover until its stop arm locks in place. |
| PUNCH | 6 | (b) Disconnect mode switch assembly from under keyboard hood. |

1. GENERAL

1.01 This section provides instructions for removal and replacement of Model 38 Automatic Send-Receive (ASR) components. It is reissued to make some changes. Marginal arrows indicate the changes. If disassembly and reassembly of components is required, refer to the related component section.

1.02 For tools to remove and replace components, refer to Section 570-005-800TC.

CAUTION: DISCONNECT POWER AND REMOVE CONNECTORS FROM EXTERNAL RECEPTACLES.

2. REMOVAL AND REPLACEMENT OF COMPONENTS

COVER

2.01 Remove cover (Figure 1) from teletypewriter as follows:

- (a) Pivot cover until its stop arm locks cover in place.

KEYBOARD HOOD

2.03 Remove keyboard hood (Figure 2) as follows:

- (a) Pivot cover until its stop arm locks in place.
- (b) Disconnect mode switch assembly from under keyboard hood.
- (c) Disengage keyboard hood latches (left and right side) from keyboard.
- (d) Slide keyboard hood forward, and remove it from keyboard.

2.04 Replace keyboard hood by reversing procedure in 2.03.

KEYBOARD

2.05 Remove keyboard (Figure 3) as follows:

- (a) Remove cover and keyboard hood, 2.01 and 2.03.
- (b) Disconnect J3 from P3 on connector panel at rear of printer.
- (c) Disengage cable from cable clip on base pan at right of keyboard.

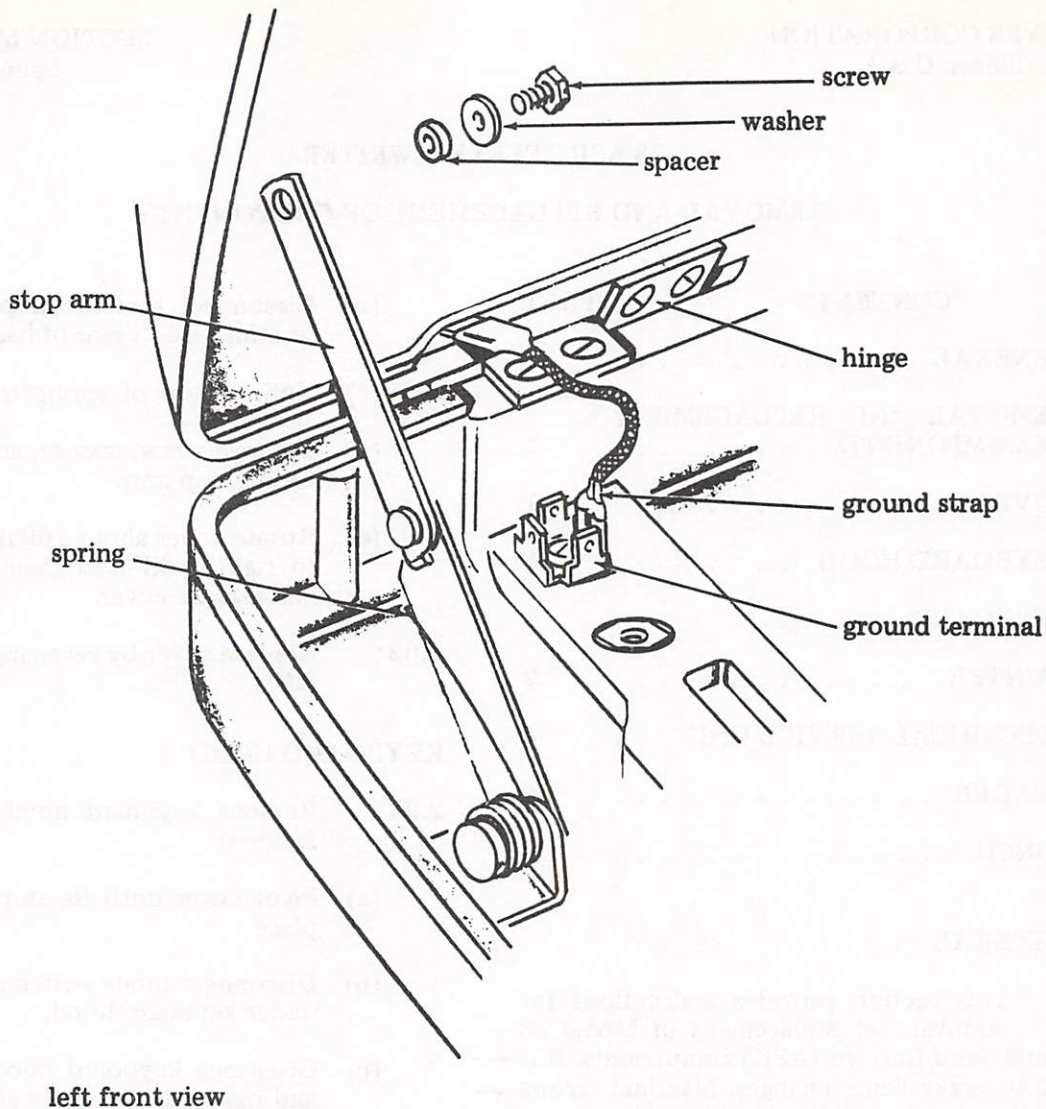

Figure 1 - 38 Teletypewriter Cover

(d) Remove two mounting screws (at left and right side of keyboard) from mounting brackets.

(e) Insert screwdriver in slot of H-plate and slide plate left until it disengages from trip arm, then remove H-plate.

2.06 Replace keyboard by reversing procedure in 2.05. →

PRINTER

2.07 Remove printer (Figure 4) as follows:

(a) Remove cover and keyboard hood, 2.01 and 2.03. →

(b) Disconnect J3, J6, and J8 from connector panel at rear of printer.

(c) Disconnect J17 (three-wire motor cable) from P17.

(d) Remove ground wire (green lead) from under the screw at rear hole in connector panel.

(e) Disconnect ground strap from terminal at rear of base pan.

(f) Lift printer from base pan; do not lift printer from selector. Grasp corners of printer casting to lift up.

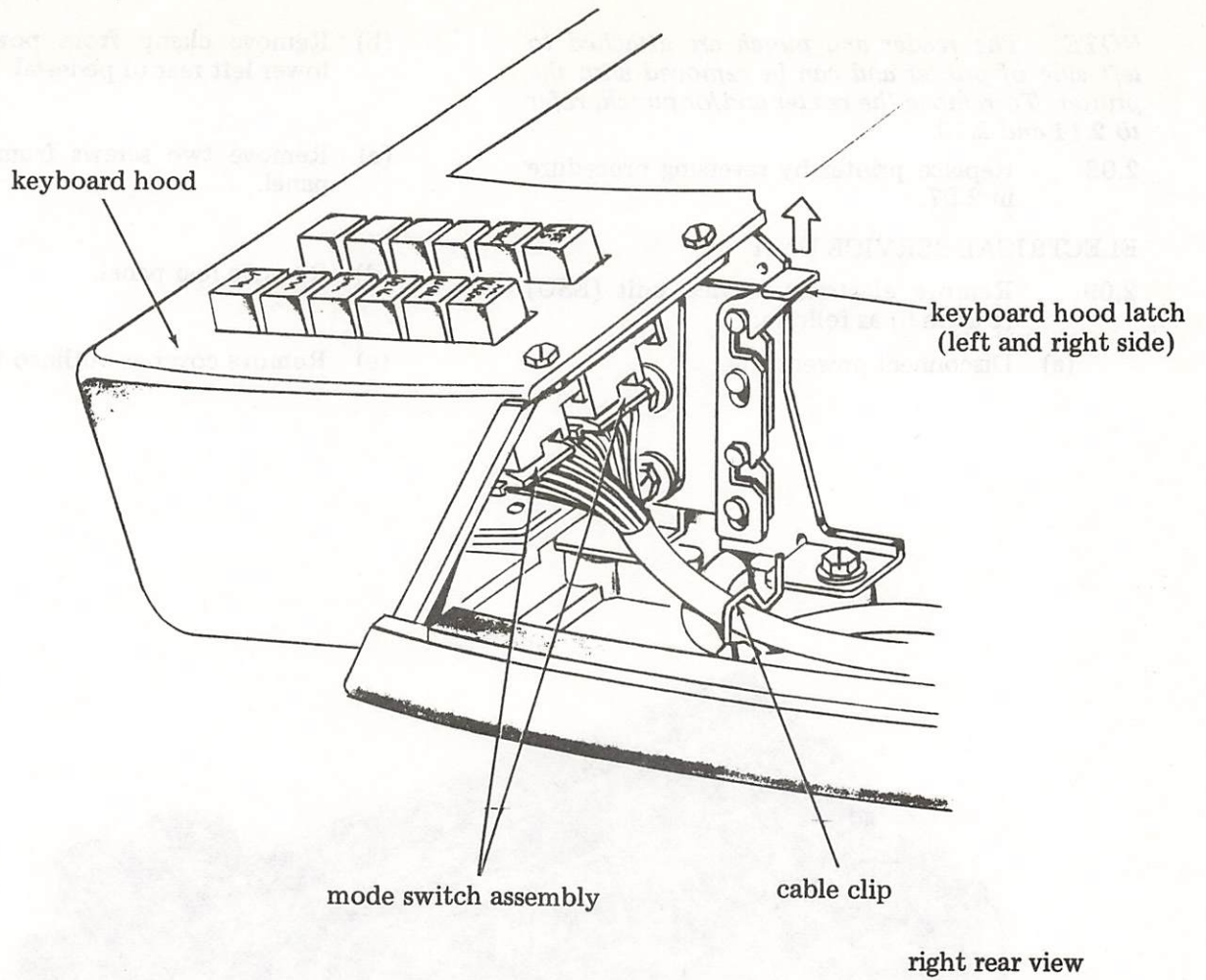

Figure 2 - Keyboard Hood

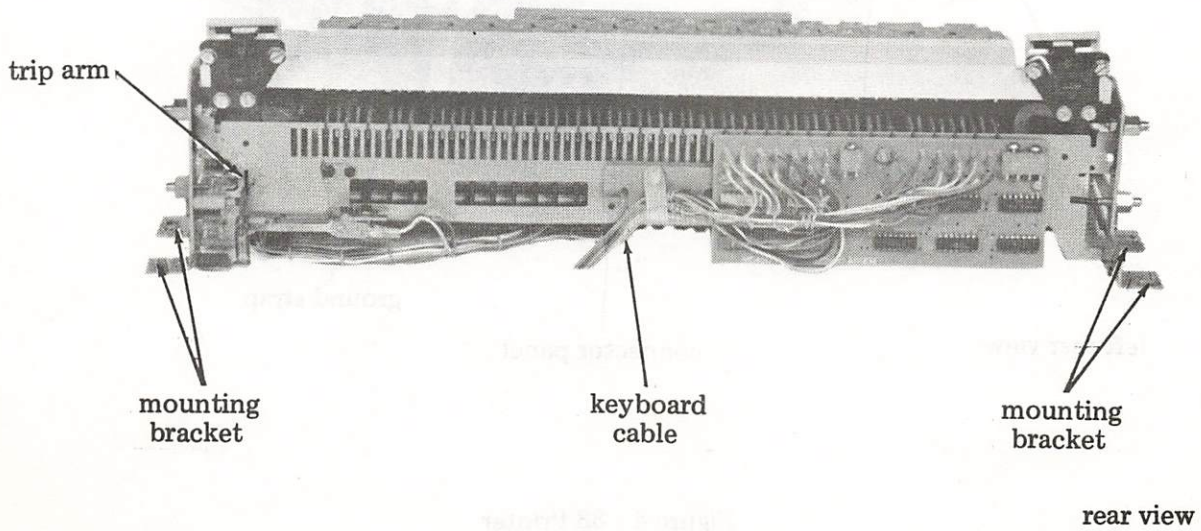

Figure 3 - Keyboard

NOTE: The reader and punch are attached to left side of printer and can be removed with the printer. To remove the reader and/or punch, refer to 2.11 and 2.13.

2.08 Replace printer by reversing procedure in 2.07.

ELECTRICAL SERVICE UNIT

2.09 Remove electrical service unit (ESU) (Figure 5) as follows:

(a) Disconnect power cable.

(b) Remove clamp from power cable at lower left rear of pedestal.

(c) Remove two screws from top of rear panel.

(d) Remove rear panel.

(e) Remove cover as outlined in 2.01.

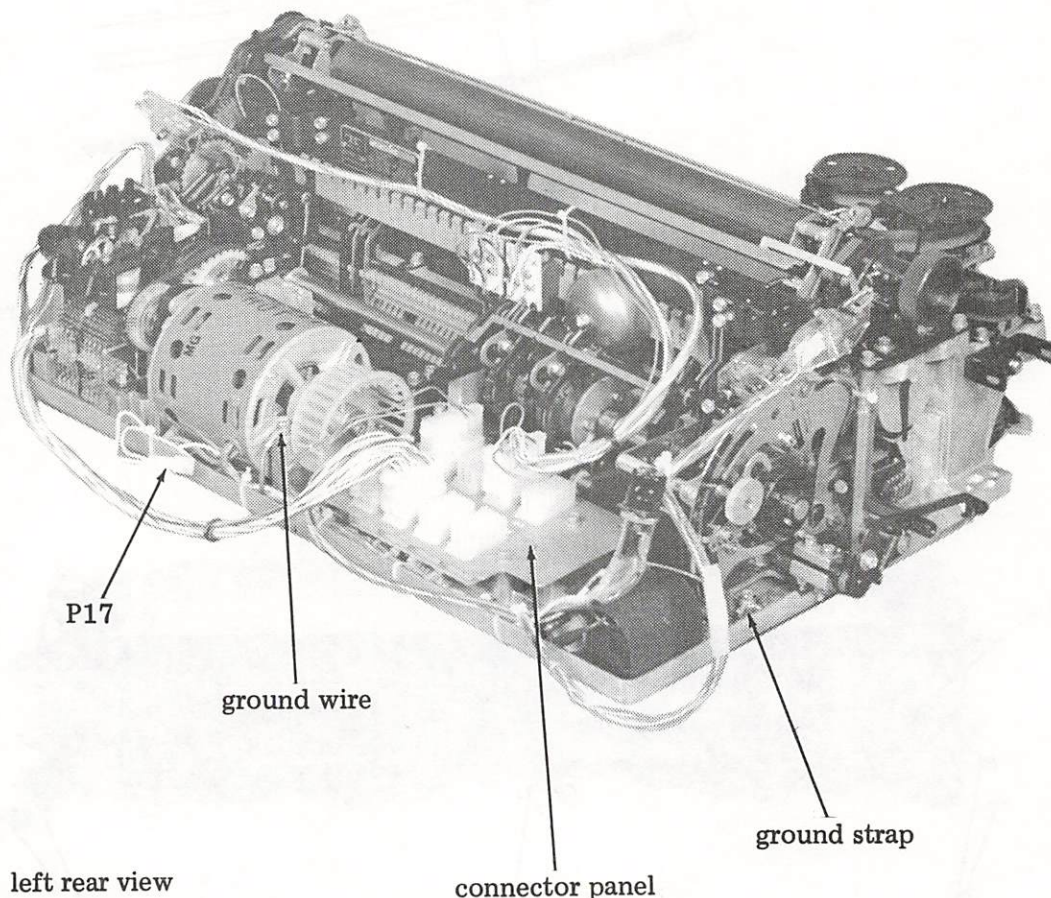

Figure 4 - 38 Printer

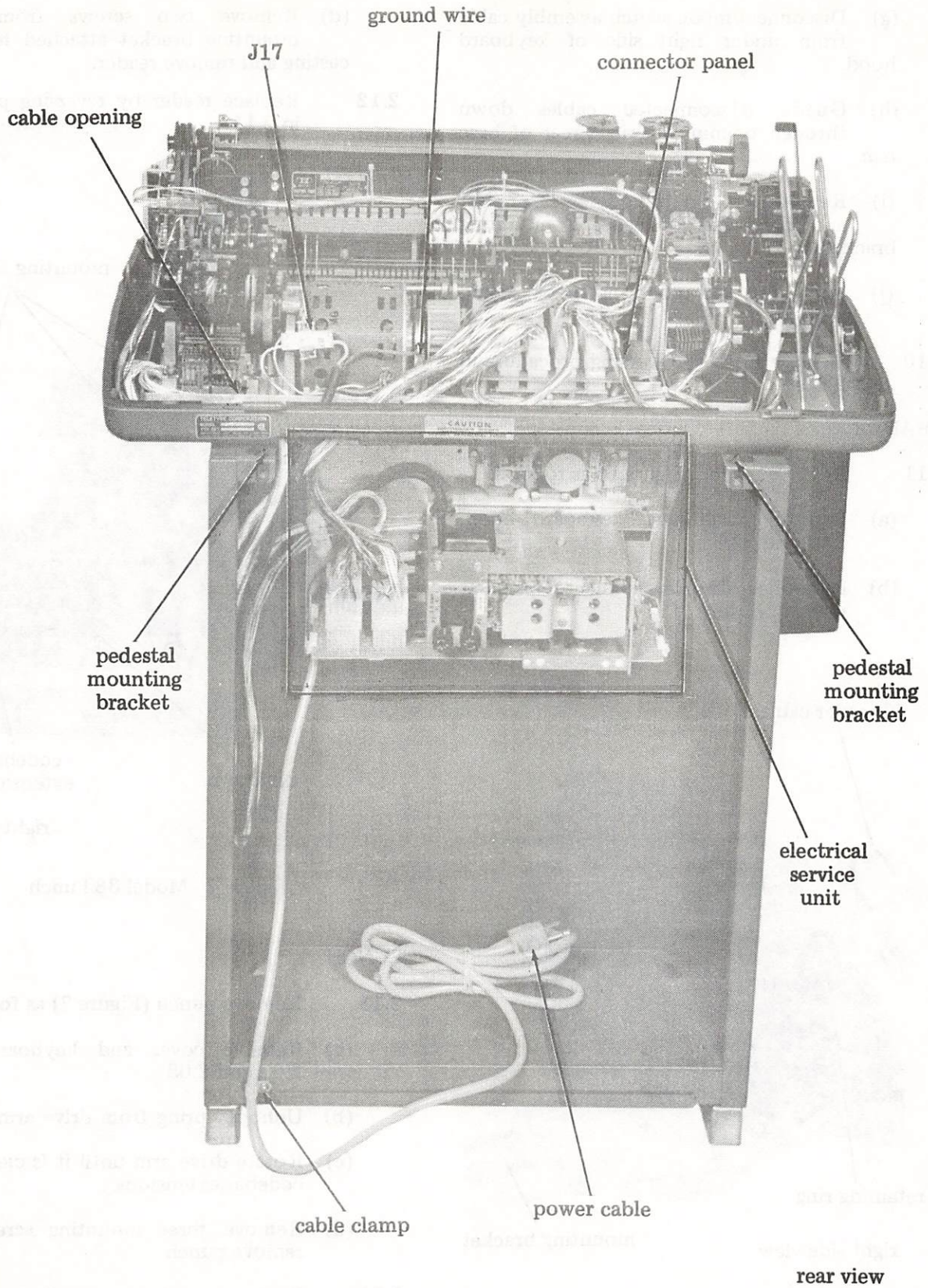

Figure 5 - Electrical Service Unit

- (f) Disconnect J6 and J8 from connector panel at rear of printer.
- (g) Disconnect mode switch assembly cable from under right side of keyboard hood.
- (h) Guide disconnected cables down through opening at right rear of base pan.
- (i) Remove two mounting screws from left and right side of pedestal mounting brackets.
- (j) Slide ESU off mounting brackets and remove.

2.10 Replace ESU by reversing procedure in 2.09.

READER

2.11 Remove reader (Figure 6) as follows:

- (a) Remove cover and keyboard hood, 2.01 and 2.03.
- (b) Disconnect J2 from connector panel at rear of printer.

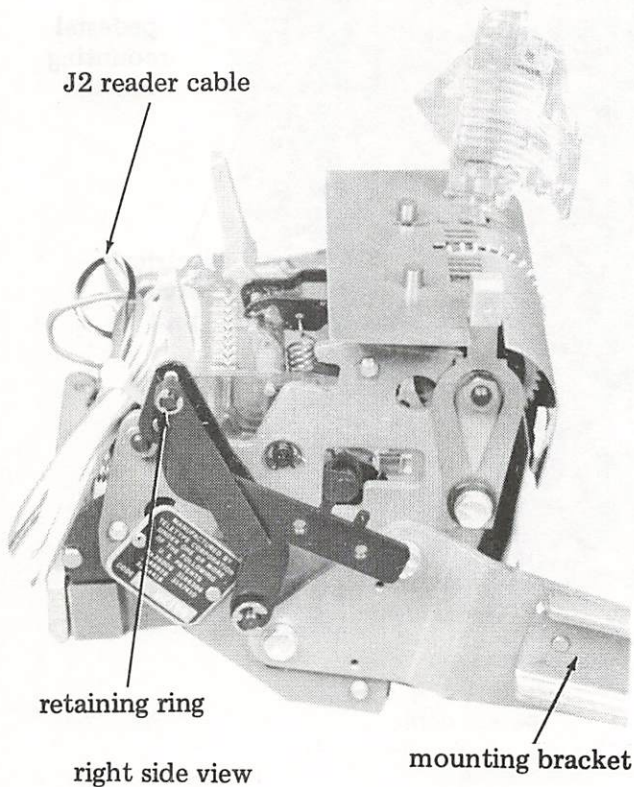

Figure 6 - Model 38 Reader

- (c) Remove retaining ring from control arm drive link.
- (d) Remove two screws from reader mounting bracket attached to printer casting and remove reader.

2.12 Replace reader by reversing procedure in 2.11.

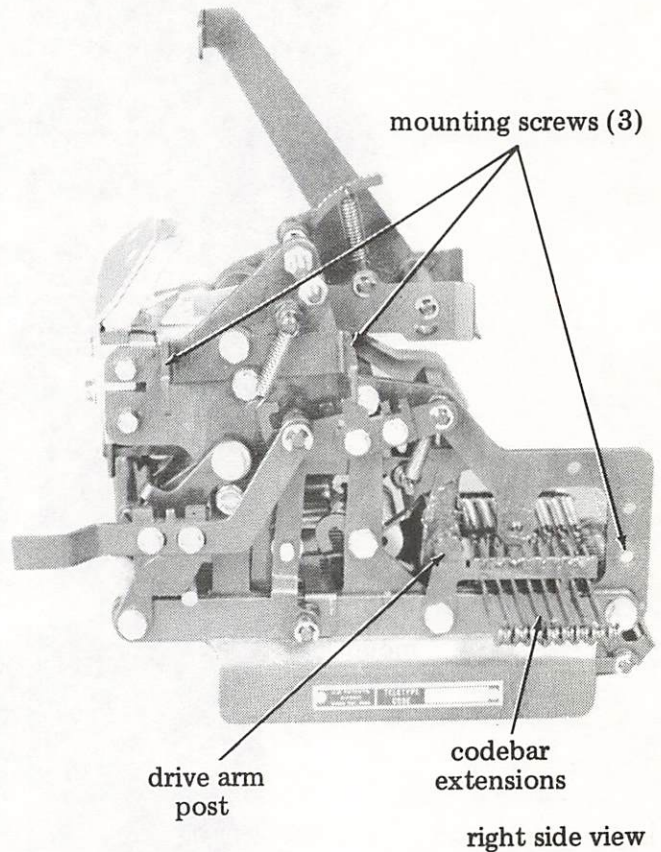

Figure 7 - Model 38 Punch

PUNCH

2.13 Remove punch (Figure 7) as follows:

- (a) Remove cover and keyboard hood, 2.01 and 2.03.
- (b) Unhook spring from drive arm control.
- (c) Rotate drive arm until it is clear of the codebar extensions.
- (d) Remove three mounting screws, and remove punch.

2.14 Replace punch by reversing procedure in 2.13.

38 KEYBOARD UNIT

DESCRIPTION AND PRINCIPLES OF OPERATION

| CONTENTS | PAGE |
|--------------------------------------|------|
| 1. GENERAL | 1 |
| 2. DESCRIPTION | 1 |
| FEATURES | 1 |
| TECHNICAL DATA | 6 |
| 3. PRINCIPLES OF OPERATION | 7 |
| KEYBOARD OPERATION | 9 |
| SHIFT KEY MECHANISM | 11 |
| SHIFT LOCK | 11 |
| CONTROL KEY MECHANISM | 12 |
| CONTROL FUNCTIONS | 12 |
| KEYLEVER MECHANISM | 13 |
| SPACE MECHANISM | 14 |
| CODEBAR MECHANISM | 15 |
| CONTACT MECHANISM | 16 |
| UNIVERSAL MECHANISM | 18 |
| TRIP ARM | 19 |
| REPEAT MECHANISM | 21 |
| TRIP ARM RESET | 22 |
| ELECTRICAL OPERATION | 23 |
| 4. KEYBOARD FOR APL SETS | 27 |

1. GENERAL

1.01 This section provides the description and principles of operation for the 11-unit code 38 keyboard unit (Figure 1). It is reissued to add information for the keyboard

used on APL (A Programming Language) sets. Marginal arrows used to indicate changes or additions are omitted since Part 4 is the only addition to this section.

1.02 The keyboard unit provides mechanical to electrical conversion of an 8-level parallel code. Depressing the keytops convert, through a set of contacts, the mechanical motion into parallel electrical code paths. These paths, when connected into external electronic logic, are converted into 7-level ASCII (American National Standard Code for Information Interchange — X3.4-1968). The 8th bit level in the keyboard output is for parity.

1.03 Specific information covering adjustments, lubrication, and disassembly and reassembly of the keyboard unit, can be found in Sections 574-421-700TC, 574-421-701TC, and 574-421-702TC, respectively.

2. DESCRIPTION

2.01 The keyboard unit contains the major mechanisms to establish the 7-bit code for 128 graphic and function characters and the 8th parity bit. A graphic is a character which is printed and a function causes a mechanical or electrical action to be performed.

2.02 The major mechanisms are described in the upper portion of Figure 1. The keyboard mechanism is further divided into several basic mechanisms which are identified in Figures 2 and 3.

FEATURES

2.03 The keyboard is a 4-row configuration similar to the standard typewriter; Figures 4, 5, and 6 show the standard arrangements. The keyboard is capable of generating 128 ASCII characters and presenting them in parallel wire form to the transmitter distributor located in back of the printer unit. The distributor converts the code to a serial form for the printer, perforator, and reader, or to be sent over the signal line.

KEYBOARD MECHANISM

- Contains required keytops, codebars, and contacts to provide electrical paths for parallel code output.
- Upper and lower case characters. Keytop arrangement similar in appearance and operation to standard office typewriter.
- Special primary keys for frequently used control functions.
- Repeat character feature on any key without special repeat key.
- Transmission rate up to 100 words per minute.
- Parity keyboard. Originates 8-level coded characters where level 8 is used for even parity.

KEYTOP GUIDE

- Restrains horizontal motion of keytops.
- Protects keyboard mechanism from dust and other hazards.

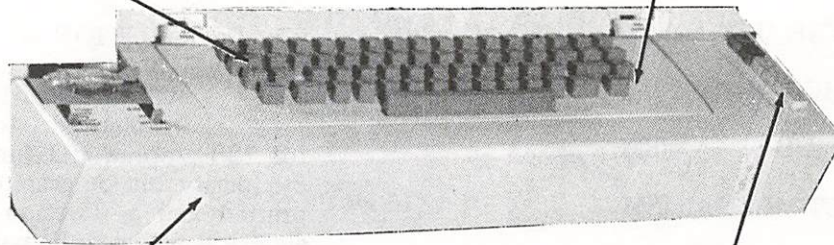

front view

KEYBOARD HOOD

- Protects keyboard, reader and punch mechanisms from dust and other hazards.

CONTROL PANEL

- Local function keys.
- Special control keys and indicators.
- Additional keys and indicators may be added as required.

Figure 1 - Keyboard Unit

KEYBOARD LOGIC CARD

- Controls keyboard output to the distributor.
- Converts the keyboard parallel input to eight parallel output ASCII characters.
- Strapping options, 8th bit always marking or 8th bit always spacing, and all capitals generated from keyboard.

MOUNTING BRACKETS (each side)

- Provides facility to mount keyboard to printer casting.

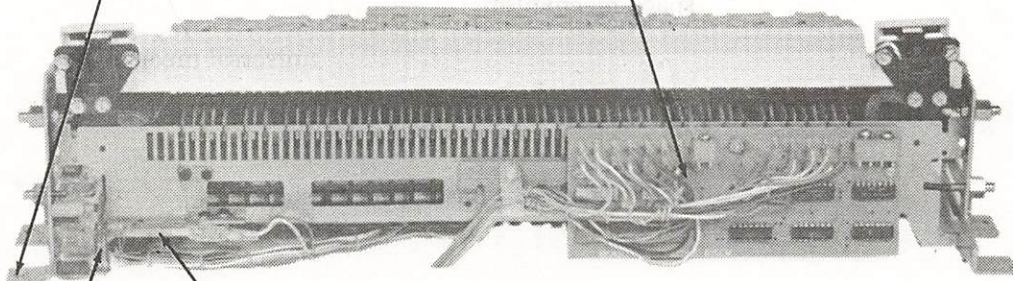

rear view

KEYBOARD TRIP ARM

- Interfaces with the printer.
- Mechanically driven from printer.
- Mechanically resets keyboard mechanism.
- Operates enable contact.

ENABLE CONTACT

- Prevents a code sample during an idle condition.
- Open condition disables keyboard input logic.
- Closed condition completes ground path to keyboard contacts and input logic levels are established.
- Controls sampling period of contact mechanism.

Figure 2 - Keyboard Unit

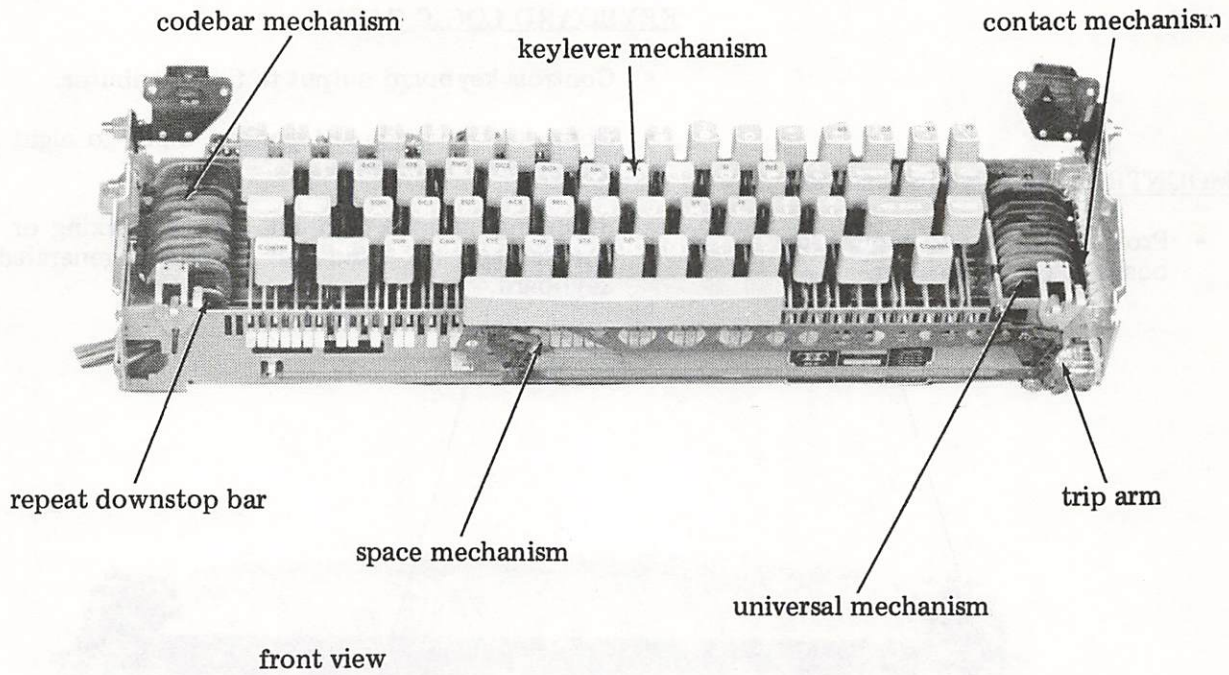

Figure 3 - Basic Mechanisms

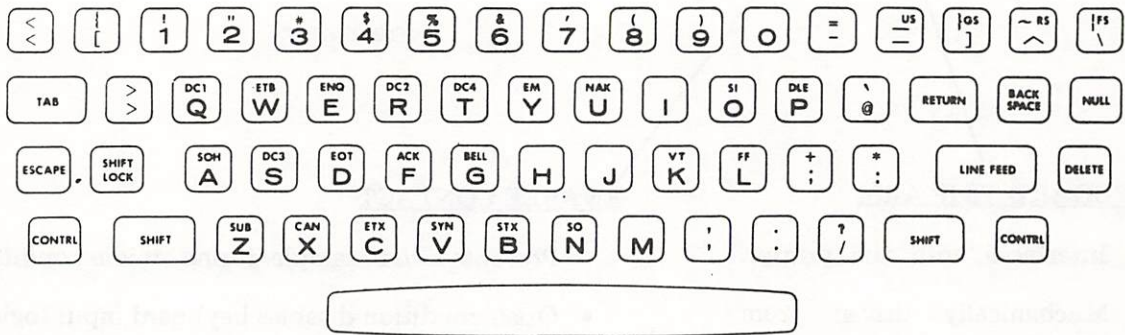

Figure 4 - AAW Keyboard Arrangement

2.04 The keyboard logic circuit card is mounted in back of the keyboard unit. This circuit card can be programmed through screw strap options for 8-bit marking or spacing, parity, or all upper case printing. As shipped from the factory the keyboard is enabled for upper and lower case, and for even parity operation (screw A tight, screw B loose, screw C loose on keyboard circuit card located at the rear of the keyboard). To enable keyboard for all capitals generation, tighten screw C. For 8th bit always marking, tighten screws A and B. For 8th bit always spacing, loosen screws A and B, refer to Figure 7.

Keylever Interlock

2.05 The keylever interlock prevents depressing of two or more primary keys simultaneously to a point where the keyboard is tripped. This prevents generation of a faulty code. Interlocking is accomplished by complimentary coding of the codebars.

Code Selection Lock

2.06 The code selected by depressing a key is locked in place by the trip arm. The trip arm locks the codebars in position during the code sampling period. At the end of the code sampling period, the reset mechanism on the printer returns the trip arm to its unoperated position, thus removing the code selection lock.

Nonrepeat and Repeat

2.07 The nonrepeat and repeat features are provided for all keylevers which trip the keyboard mechanism. If a key is nonrepeatable, the operator must release the depressed key and depress again to transmit the same character. The repeat feature provides transmission of a selected character by further depression of the key beyond the normal downstop position. The character is continuously transmitted until the key is released.

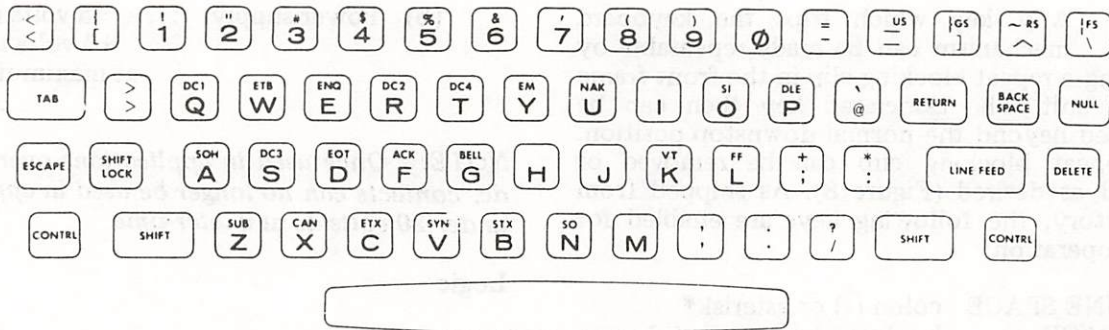

Figure 5 - ABW Keyboard Arrangement

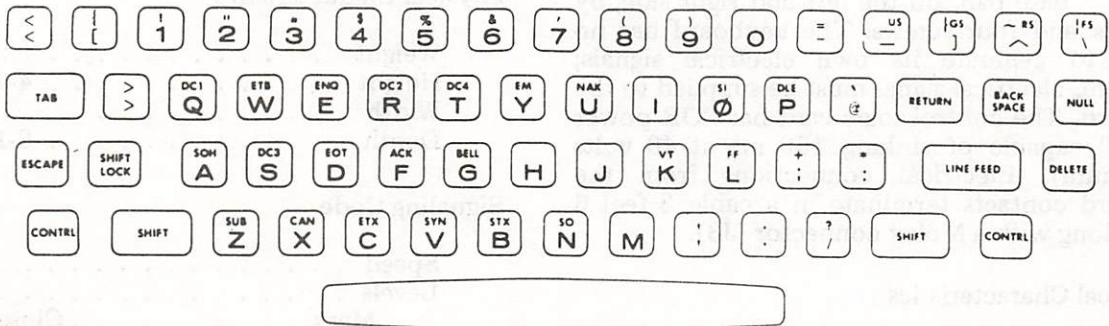
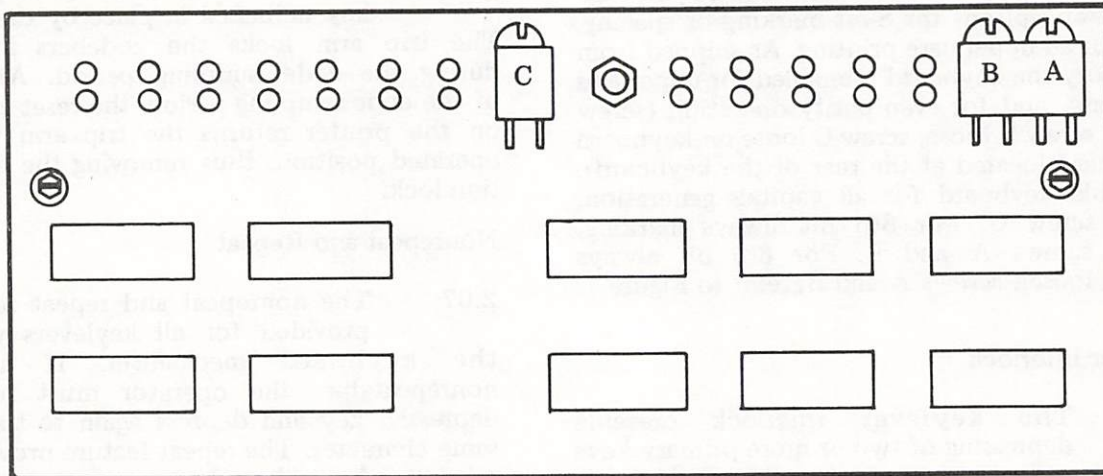

Figure 6 - ACW Keyboard Arrangement



rear view

Figure 7 - Keyboard Circuit Card

2.08 Any key which trips the keyboard mechanism can be made repeatable by removing a repeat blocking clip in the front frame of the unit. The associated key then can be depressed beyond the normal downstop position. The repeat blocking clip can be removed or inserted as desired (Figure 8). As shipped from the factory, the following keys are enabled for repeat operation:

- LINE SPACE colon (:) or asterisk*
- SPACE hyphen (-) or equals (=)
- NULL shift and unshift period (.)
- DELETE shift and unshift underscore (-)
- upper and lower case (X)

TECHNICAL DATA

2.09 The 38 keyboard mounts to the cover base pan, on the left and right side, by brackets and four screws. The keyboard has no means to generate its own electrical signals; therefore, electrical signal must be supplied to the keyboard. The control logic card has "OR power drivers" capable of sinking 150 ma at 40 volts (maximum). Electrical connections from the keyboard contacts terminate in a cable 3 feet 6 inches long with a Molex connector (J3).

Electrical Characteristics

- (a) Electrical contact ratings 5 volts at 3.3 ma

- (b) Power supply . . . +5 volts minimum
+6 volts maximum
at maximum current
of 180 ma

NOTE: Once used in applications over 20 volts dc, contacts can no longer be used in applications under 20 volts dc at a later time.

Logic

| DESCRIPTION | LOW | HIGH |
|------------------|--------------------------------------------|---------------------|
| Binary state | 1 | 0 |
| Signal condition | mark | space |
| Voltage level | between circuit ground and 0.5 volts | +2.5 and 6 volts |

Physical Characteristics

- Weight 5 pounds
- Height 4-1/4 inches
- Width18 inches
- Depth 6-1/4 inches

Signaling Code

- Speed 100 WPM
- Levels Eight
- Mark Closed contact
- Space Open contact
- Parity Even

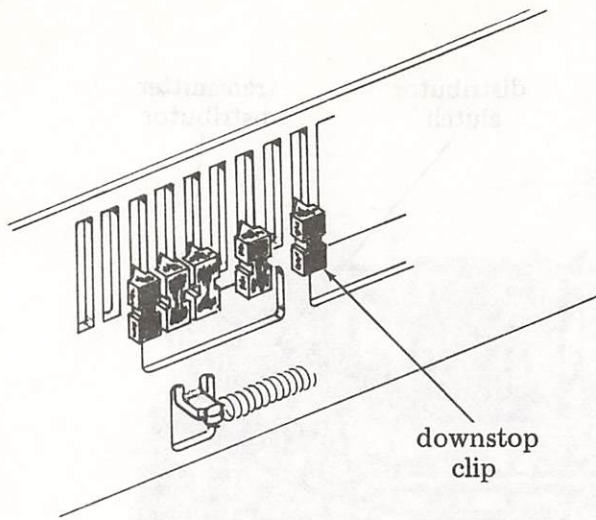

Figure 8 - Repeatable Key Feature

Keylever Spring Tension

Normal Less than 7 ounces
 Repeat Less than 54 ounces

Environment

Temperature Ranges — This equipment is intended to be operated in a room environment within the temperature range of 40° F to 110° F. Serious damage to it could result if this range is exceeded. In this connection, particular caution should be exercised in using acoustical or other enclosures.

Relative humidity range

Minimum 0%
 Maximum 95%

Character Arrangement

2.10 The character arrangement of the keytops is as shown in Figures 4, 5, and 6. The keytop arrangement is similar to that of a standard office typewriter. In addition, frequently used control functions are provided as primary keys. Designations within keytop are as they appear on the mechanism. Designations shown above the keytop are control function legends. The following chart lists the control character legend and designation. The function as screened on the keytop is listed for those designations where the screening and legend differ.

Control Characters

| <u>LEGEND</u> | <u>DESIGNATION</u> |
|---------------|--------------------|
| ACK | — Acknowledge |
| BEL | — Bell |
| BS | — Backspace |

LEGEND

DESIGNATION

| | |
|-----|-------------------------------|
| CAN | — Cancel |
| CR | — Carriage return (RETURN) |
| DC1 | — Device control 1 |
| DC2 | — Device control 2 |
| DC3 | — Device control 3 |
| DC4 | — Device control 4 |
| DEL | — Delete |
| DLE | — Data link escape |
| EM | — End of medium |
| ENQ | — Enquiry |
| EOT | — End of transmission |
| ESC | — Escape (PREFIX) |
| ETB | — End transmission block |
| ETX | — End text |
| FF | — Form feed |
| FS | — File separator |
| GS | — Group separator |
| HT | — Horizontal tabulation (TAB) |
| LF | — Line feed (LINE FEED) |
| NAK | — Negative acknowledge |
| NUL | — Null |
| RS | — Record separator |
| SI | — Shift in |
| SO | — Shift out |
| SOH | — Start of heading |
| SP | — Space |
| STX | — Start text |
| SUB | — Start of special sequence |
| SYN | — Synchronize |
| US | — Unit separator |
| VT | — Vertical tabulation |

3. PRINCIPLES OF OPERATION

3.01 The keyboard is mechanically coupled to and operated by the distributor clutch on the printer. The interface between the printer and keyboard is through the H-plate. The H-plate connects the keyboard trip arm to the reset mechanism. Through linkage under the printer the reset mechanism is connected to the distributor clutch (Figure 9). Refer to the pictorial diagram on the keyboard operation (Figure 10) and the related descriptive outline to get an overview concerning the operation of the keyboard mechanism.

3.02 When the spacebar, function or character key on the keyboard, is depressed the keyboard trip arm is released (tripped) and through the reset mechanism trips the distributor clutch. When the distributor clutch is tripped, it operates and starts the transmitter distributor which process the selected code. The enable contacts, on the back of the keyboard, lock this code in the keyboard circuit until the data bits have been sequentially transmitted. When the distributor clutch has made one complete revolution, the clutch latches, operating the reset mechanism which resets the keyboard trip arm and opens the enable contacts.

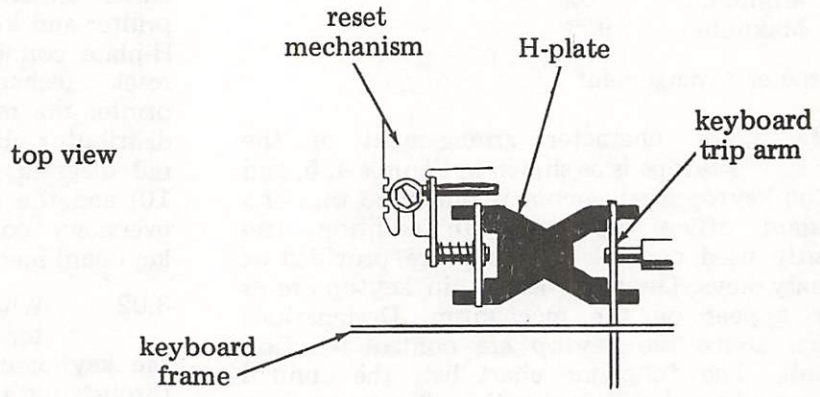
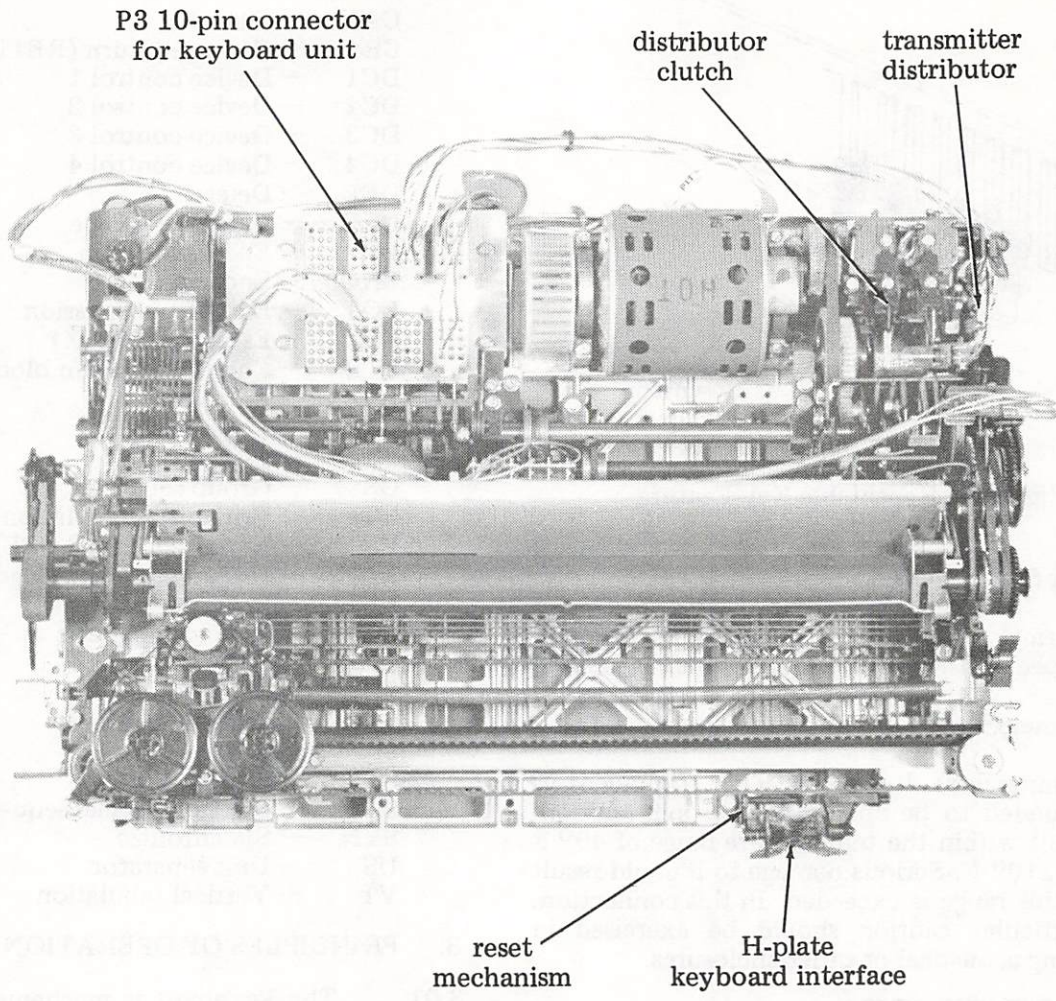

Figure 9 - 38 Printer

3.03 The principles of operation are divided into the mechanical operation and the electrical code generating logic of the keyboard unit. The mechanical operation is presented in: (1) a pictorial schematic of the unit; and (2) a series of mechanism drawings. Each illustration is supported with appropriate text to describe the purpose and operation of the mechanism. Where possible, the mechanism drawings are arranged in the order in which the mechanism operates. The electrical operation is limited to the elements which logically generate the eight levels of binary information.

KEYBOARD OPERATION

- A. Attendant holds depressed SHIFT key, to modify output of contact mechanism, while depressing a key for capital letters or symbols.
- B. Attendant holds depressed the CONTRL key, to modify output of contact mechanism, while depressing one of the function keys (eg, ETB, NAK or STX etc).

- C. Attendant depresses a character or function key in conjunction with A. or B. above.
- D. Attendant operates codebars other than SHIFT or CONTRL.
- E. Attendant operates SPACEBAR.
- F. Arrange code generating contacts.
- G. Engage and operate universal codebar.
- H. Release trip arm.
- I. Enable contacts (normally open) close to initiate sampling period of contact mechanism.
- J. Keyboard output in form of circuit paths furnished to external logic for processing and character or control generation.
- K. After sampling contact mechanism, reset trip arm.

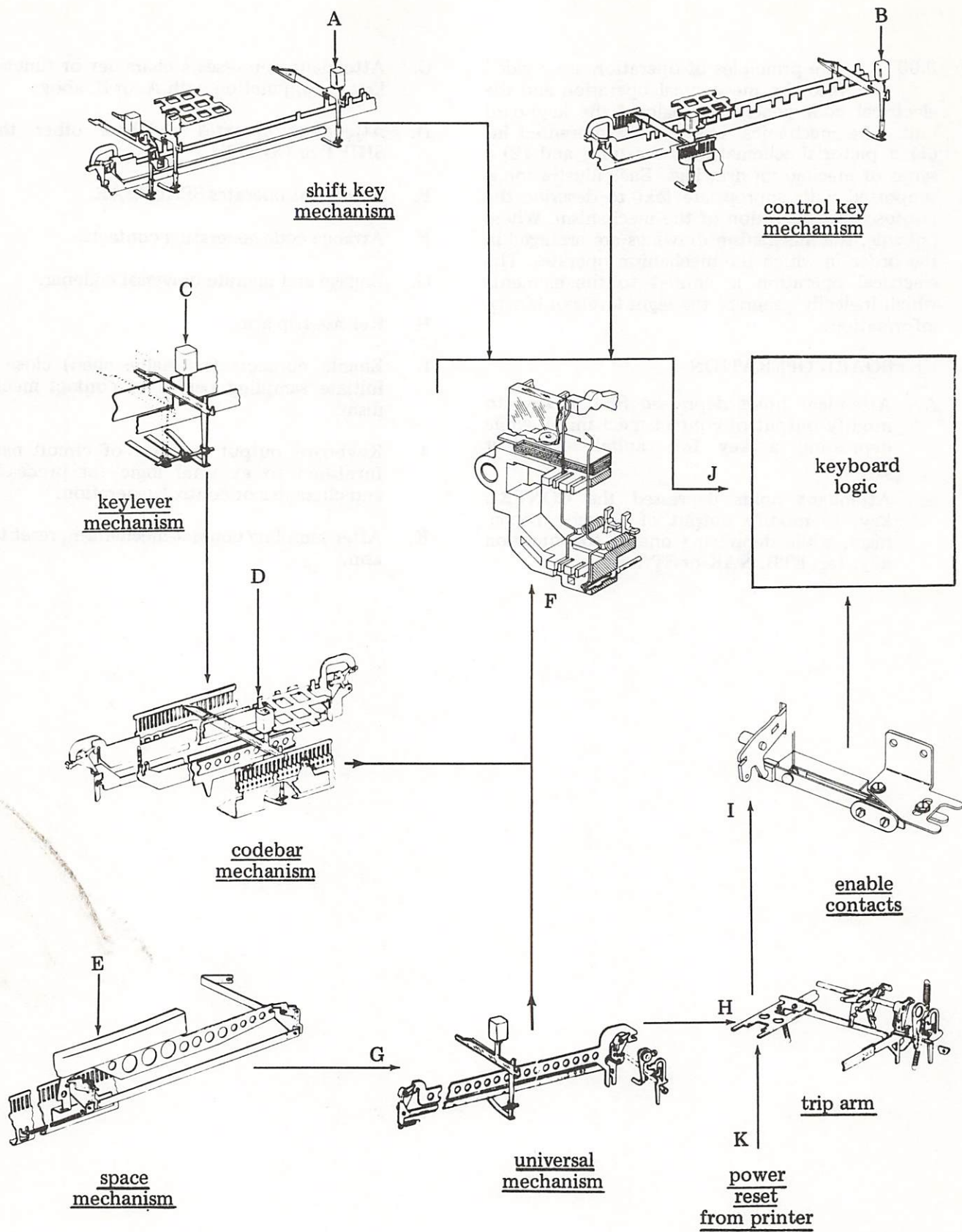

Figure 10 - Pictorial Diagram on Keyboard Operation

SHIFT KEY MECHANISM

Purpose

Changes character output of graphic primary keys from lower case graphics to upper case graphics, and mechanically blocks undesired primary keys.

Operation

The SHIFT key, when depressed, operates the shift codebar set, only. It does not trip the keyboard; ie, a recess in the SHIFT LOCK and both SHIFT keylevers prevent the keylevers from engaging the universal bar. The shift codebar set is spring biased so that the rear codebar is held upward. The rear codebar has two tine extension slots to receive the extensions of the two keylevers. When either SHIFT keytop is depressed, the other SHIFT keytop descends. The keylever

is depressed against its leaf spring and the shift codebar spring. When the rear codebar descends, the front codebar ascends to mechanically block undesired primary keys; and the shift contacts are operated to alter the keyboard logic circuit. When released, the codebar set returns to its normal unoperated condition. To generate an upper case graphic, the SHIFT key must first be depressed followed by an unblocked primary key. The primary key trips the keyboard.

SHIFT LOCK

Purpose

Holds SHIFT key down.

Operation

With SHIFT LOCK key unoperated, the shift keylever latch will pivot toward rear as the SHIFT key is depressed. As SHIFT LOCK key is depressed, the shift lock keylever extension rotates keylever latch which carries the shift keylever downward. When SHIFT LOCK key is near lower end of its travel, the shift keylever latch engages the opening in the basket frame to hold SHIFT LOCK and both SHIFT keys in their de-

pressed positions. To unlock, SHIFT key must be depressed further to unhook the shift keylever latch. Depressing SHIFT key while in lock condition will cause the shift keylever latch to rotate toward the rear and unhook itself from the basket frame. With no pressure on SHIFT LOCK key, the shift lock keylever will lead the shift keylever upward travel, thereby holding shift keylever latch toward the rear as both keys ascend.

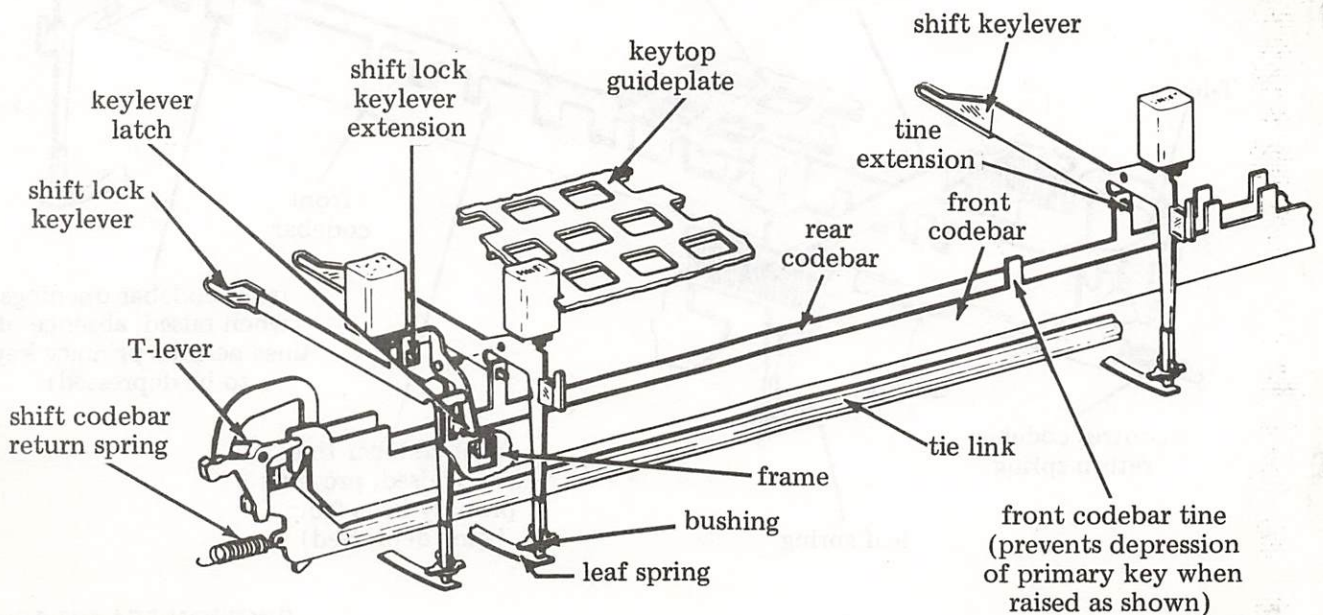

CONTROL KEY MECHANISM

Purpose

Changes character output of certain primary keys from graphics to their control function equivalents, and mechanically blocks undesired primary keys.

Operation

The CONTRL (control) key, when depressed, operates the control codebar set only. It does not trip the keyboard, ie, a recess in each control keylever prevents the keylever from engaging the universal bar. The control codebar set is spring biased so that the rear codebar is held upward. The rear codebar accepts the CONTRL key input to operate the codebar set. When operated, the rear codebar descends as the front codebar ascends. The control contacts are operated to modify the keyboard logic

circuit. The front codebar rises to prevent certain primary keys from being depressed. The presence of a tine in the front codebar prevents the the primary key from being depressed; the absence of a tine permits the key to be depressed. The CONTRL key must first be depressed followed by an unblocked primary key in order to generate a function character. When released, the control codebar set, contacts, keylever, and keytop return to their normal unoperated position.

CONTROL FUNCTIONS

Operation

Control functions can be generated from special primary keys or from CONTRL plus graphic primary keys. The same control function cannot be generated by both methods. When a primary key exists for a

control function, eg, RETURN, both this primary key and the graphic primary key, M, would be blocked on control. RETURN can be generated in the shift or unshift mode but not in the control mode.

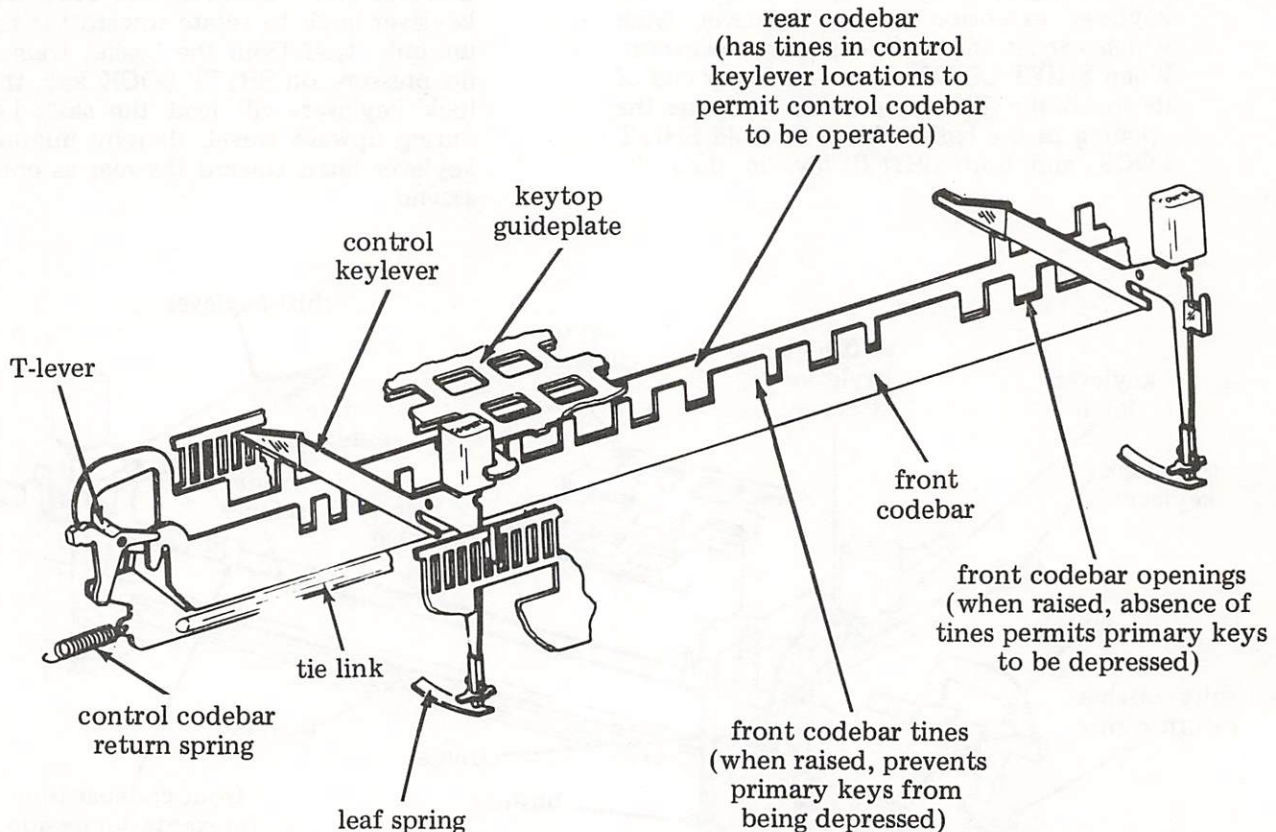

KEYLEVER MECHANISM

Purpose

Positions the codebar sets which select the code combination associated with each primary key (other than SHIFT or CONTRL), and trips the keyboard.

Operation

When a primary key is depressed, the bottom surface of the keylever may reposition up to nine of the eleven codebar sets. The other two codebar sets are related to the SHIFT and CONTRL keys which, when depressed, will prevent depression of certain primary keys. A codebar set (operated by a primary keylever) will be repositioned when the solid portion of one codebar is up, and the open portion of the other codebar is down. As the keylever descends against its leaf spring, the codebar sets not previously positioned are repositioned; and the

universal bar is engaged to trip the keyboard. (When tripped, the codebar sets are locked by the trip arm holding the code selection in position and preventing another character from being selected before the keyboard is reset.) A plastic bushing provides a guide for the keylever. If not blocked by the downstop clip, the keylever can be depressed against increased spring tension by way of the downstop bar, to repeat the character. When released, the primary key is returned to the upward position by its leaf spring.

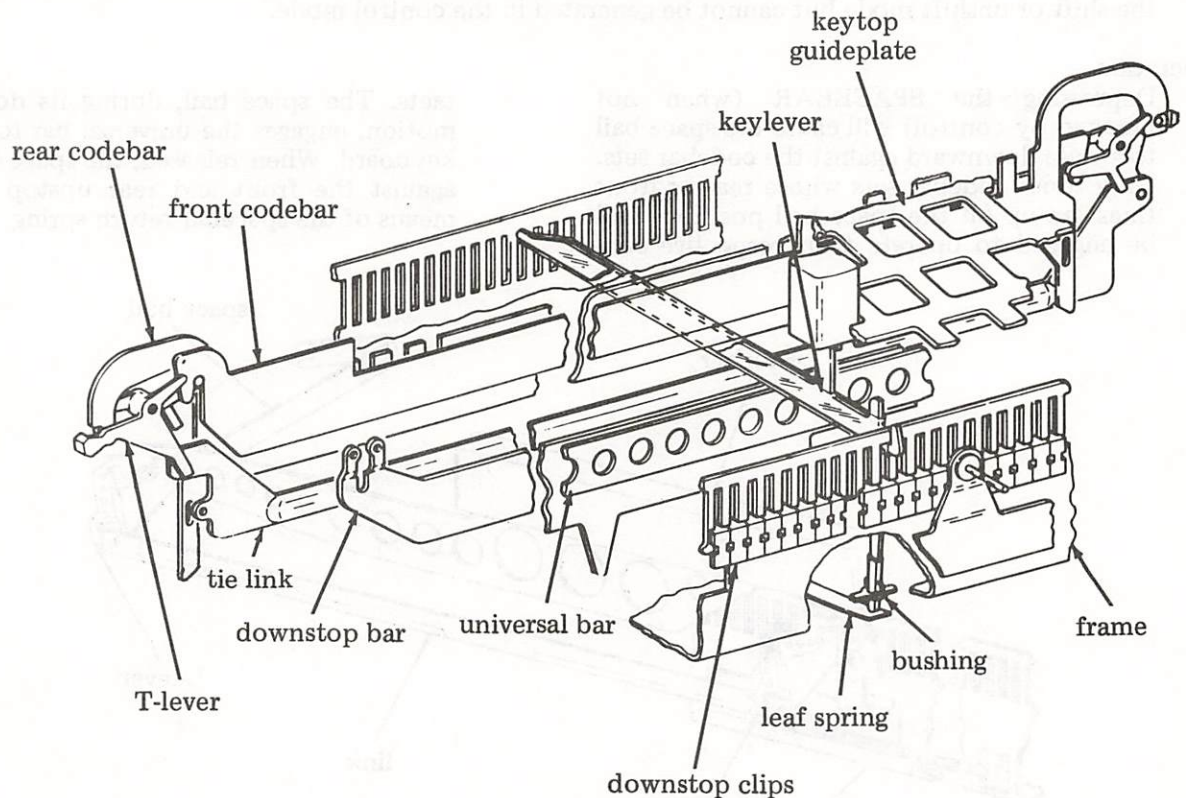

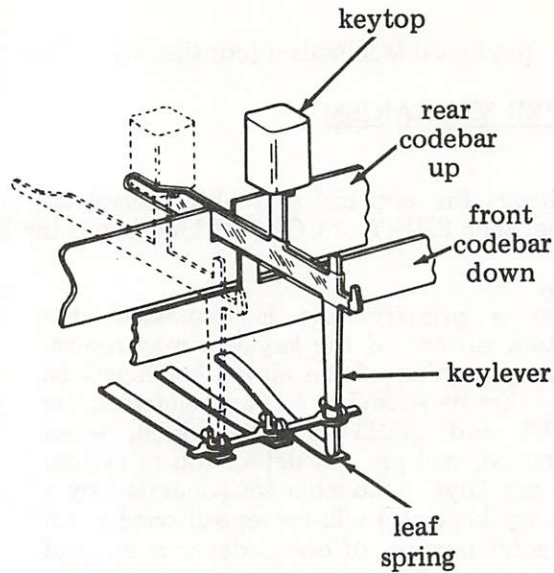
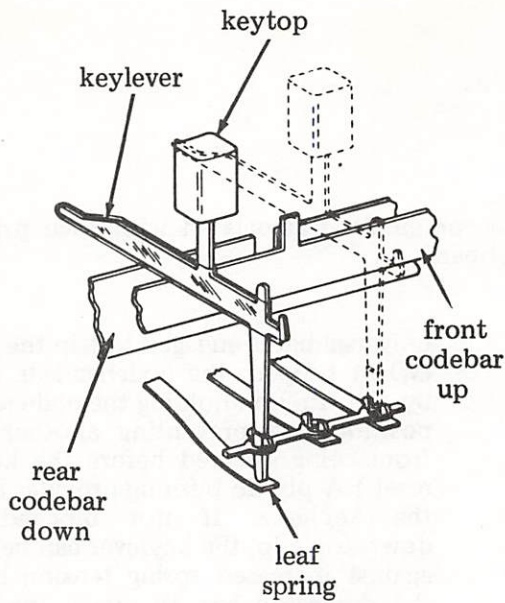

3.07 Keyboard Mechanism (continued)

SPACE MECHANISM

Purpose

Provide a means for originating the space character from a bar compatible (both in shape and location) with conventional keyboards. The space character can be generated with the keyboard in the shift or unshift mode but cannot be generated in the control mode.

Operation

Depressing the SPACEBAR (when not blocked by control) will cause the space bail to rotate downward against the codebar sets. Only those codebar sets whose rear or front tines are up (at the space bail position) will be engaged to operate their respective con-

tacts. The space bail, during its downward motion, engages the universal bar to trip the keyboard. When released, the space bail rises against the front and rear upstop bars by means of the spacebar return spring.

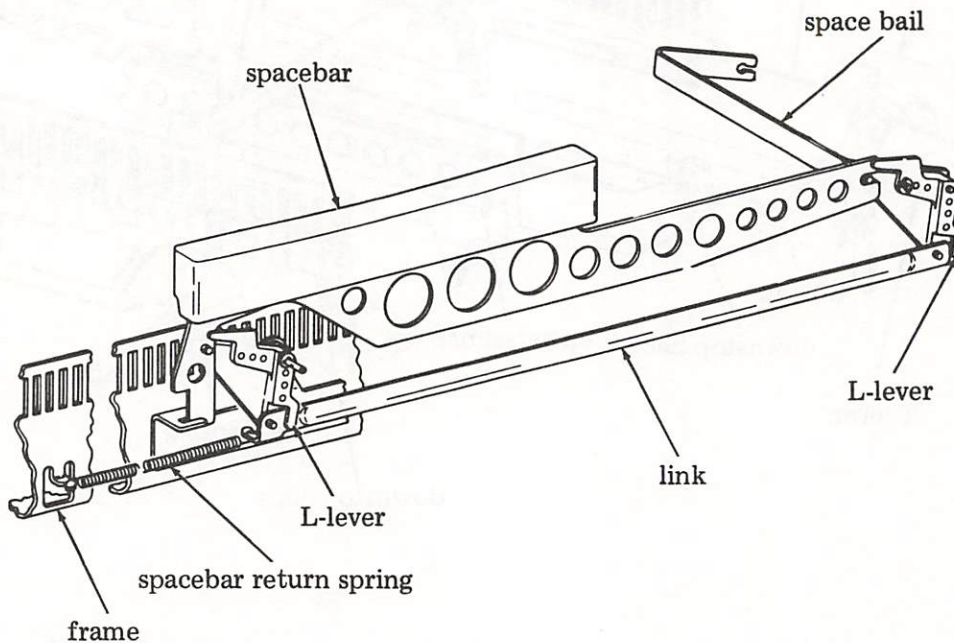

CODEBAR MECHANISM

Purpose

Provides the means for transferring keylever inputs to contact mechanism.

Operation

The codebar mechanism consists of the eight code level sets and the shift inhibit codebar set. The other two codebar sets, operated by the individual SHIFT and CONTRL keys, are associated with the shift and control mechanisms. Each codebar set consists of a front codebar, rear codebar, two T-levers, and a tie link.

Each codebar set can be placed in one of two states (binary). For purposes of discussion, the states are defined as follows: rear codebar up and front codebar down is the normal state; rear codebar down and front codebar up is the inverted state. (This state cannot be established by means of a keylever.) (The nine codebar sets are not spring biased as are the shift and control codebar sets. The normal and inverted states are based upon the assigned condition of the

associated contacts.) The nine codebar sets are positioned by a keylever mechanism. At effective keylever locations the front codebar is the compliment of the rear codebar; ie, where the front codebar is solid, the rear codebar is open, and conversely, where the front is open, the rear is solid. At ineffective keylever locations, such as SHIFT, SHIFT LOCK, and CONTRL, keylevers cannot position the codebar sets.

The two T-levers are attached to the codebar set, one at each end and are connected by the tie link. When the front codebar is down, the right end T-lever head is down; when the rear codebar is down, the right T-lever is up. The T-lever head positions the contact wires in the contact mechanism to provide the electrical code path associated with the depressed keylever mechanism.

T-lever head fully up

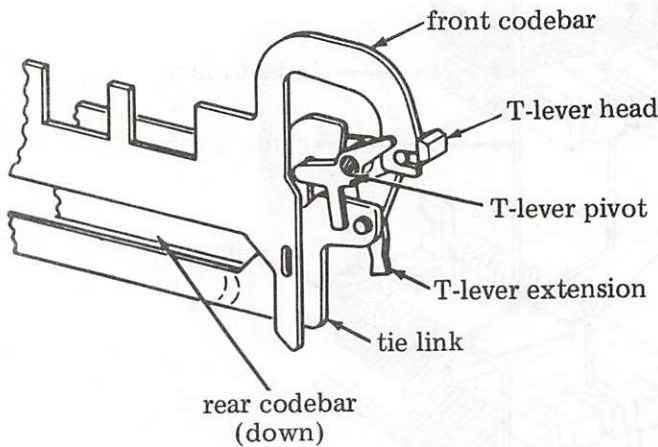

T-lever head fully down

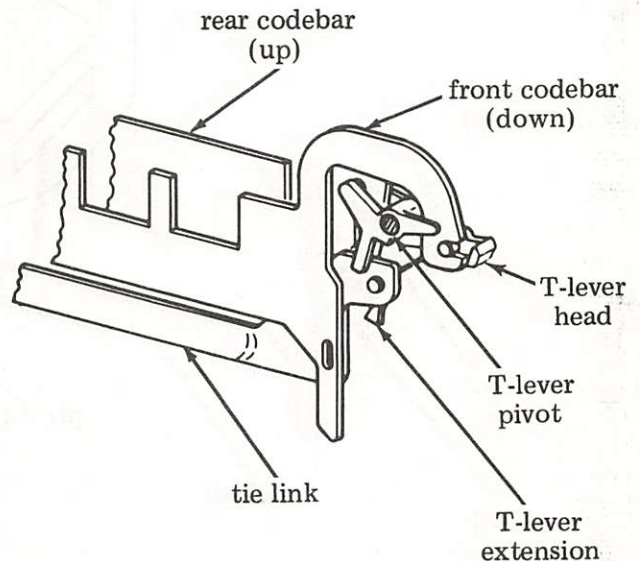

CONTACT MECHANISM

Purpose

Provides circuit paths to external keyboard logic as determined by the depression of keylevers.

Operation

The contact mechanism consists of a contact block, a contact bar, insulators, and eleven contact wires. Two types of contact wires, short and long, are used. Slotted guides in the contact block hold the contact wires in place.

Each contact wire can be placed in one of two binary states. The contact wire is spring biased to a contact bar to provide the

electrical connection. Positioning of the T-lever up establishes an electrical connection for the shorter contact wire and opens the electrical connection of the longer contact wire. Conversely, positioning of the T-lever down opens the electrical connection of the shorter contact wire and establishes an electrical connection for the longer contact wire. Refer to Paragraph 3.14 for the electrical description of the contact mechanism.

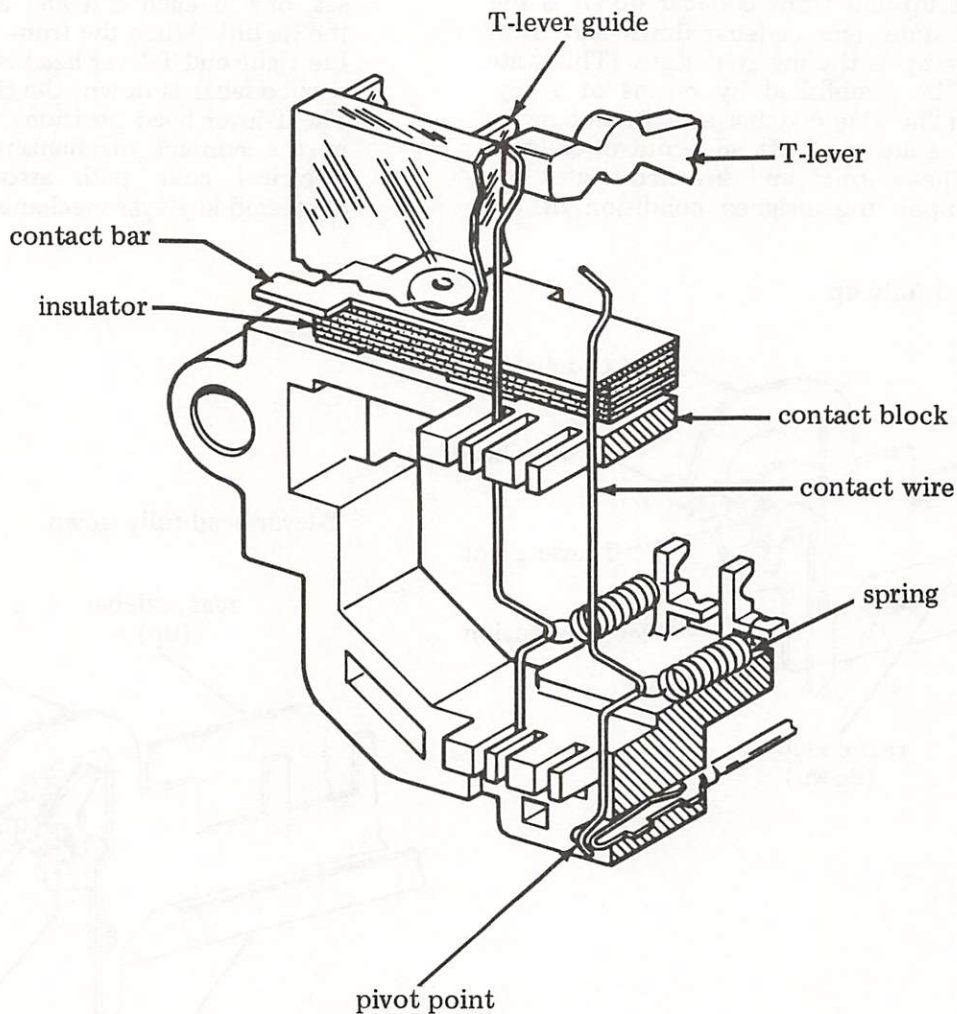

INTERNAL MECHANISM

Figure

Release the top wire

Operation

The reverse mechanism consists of a single contact which is split placed in the position and is associated upward the link is placed to the right. Operating a primary key places the contact mechanism in its locked position of the key-lever. To engage the key-lever further de-press the key-lever to the universal level. This moves the universal level to

The left of the universal level moves to the left. It engages the contact lever and the key-lever rotating from a depressed position to the primary key is depressed. Its normal downward contact the universal level to the normal level. Further to depress the key-lever. The contact lever is depressed with the depressed key-lever. The contact lever is depressed with the depressed key-lever.

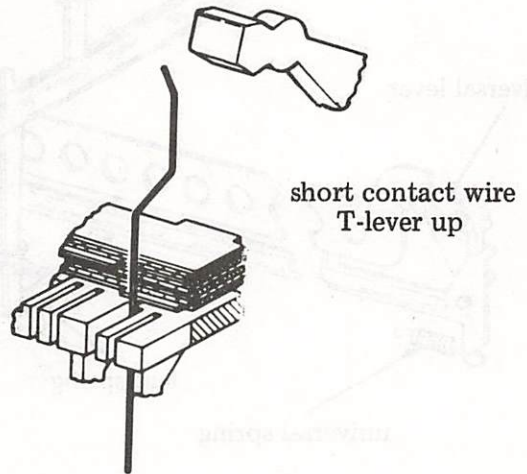
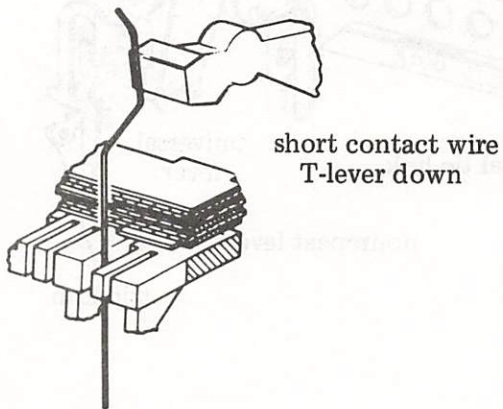
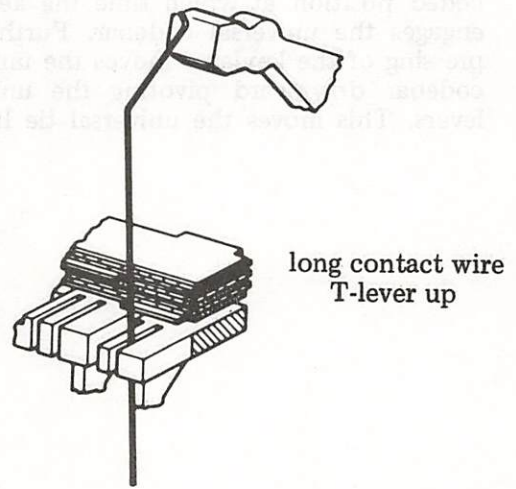
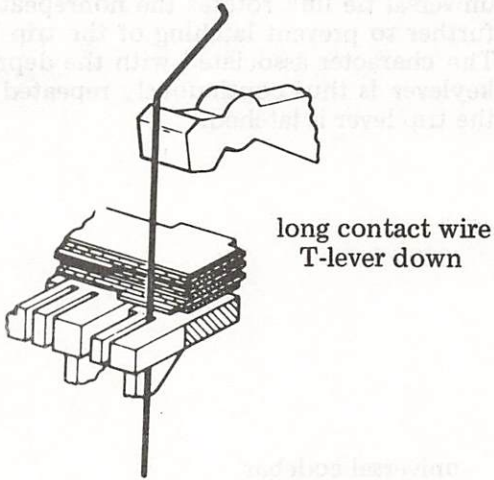

UNIVERSAL MECHANISM

Purpose
Releases the trip arm.

Operation
The universal mechanism consists of a single codebar which is spring biased in the up position and its associated universal tie link is biased to the right. Depressing a primary key places the codebar mechanism in its coded position at which time the keylever engages the universal codebar. Further depressing of the keylever moves the universal codebar downward pivoting the universal levers. This moves the universal tie link to

the left. As the universal tie link moves to the left, it engages the nonrepeat lever and latchlever rotating them clockwise, releasing the trip arm. If the primary key is depressed beyond its normal downstop position, the universal tie link rotates the nonrepeat lever further to prevent latching of the trip lever. The character associated with the depressed keylever is thus continuously repeated until the trip lever is latched.

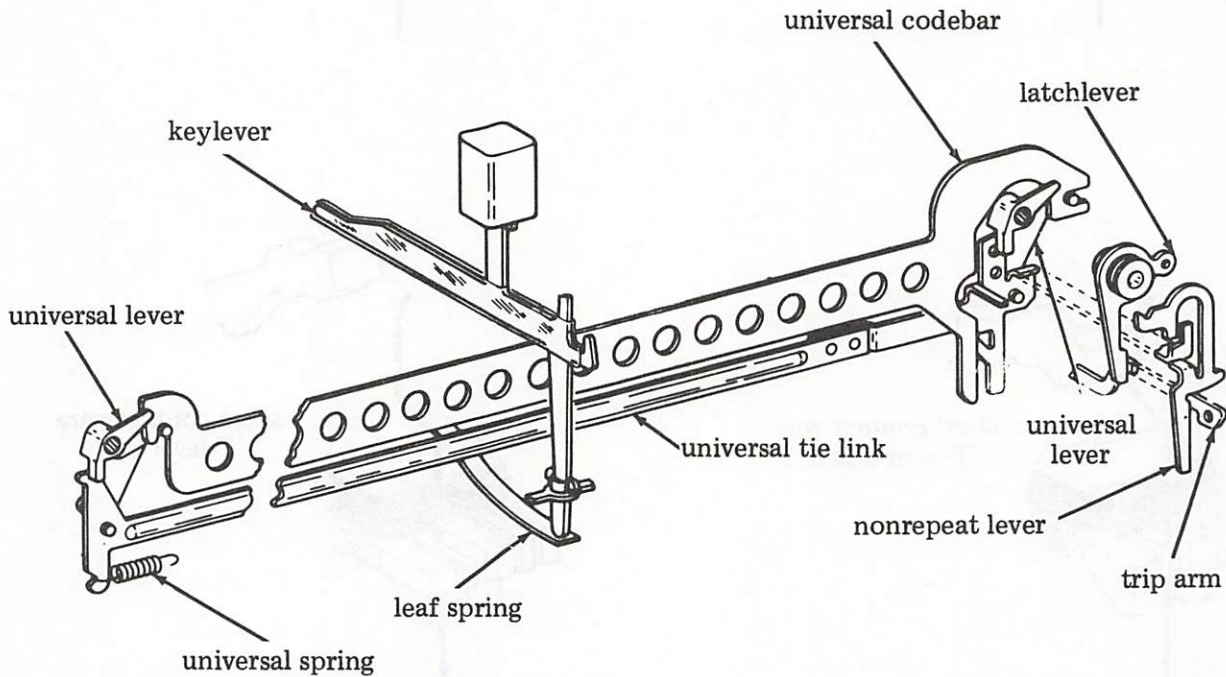

3.11 Keyboard Mechanism (continued)

TRIP ARM

Purpose

Lock T-levers in selected code position during code sampling period; trip reset mechanism; unlock T-levers at the end of code sampling period; pace operator to keyboard speed.

Operation

When the keyboard mechanism is in the unoperated condition, the trip arm is latched. When a primary key is depressed, the keylever engages the universal codebar and moves the universal tie link to the left. The universal tie link rotates the nonrepeat lever clockwise. The nonrepeat lever, in turn, rotates the latchlever clockwise releasing the trip arm. When released upward, the trip arm activates the reset mechanism. At the end of the reset mechanism cycle, the reset mechanism returns the trip arm to the

latched position.

Holding the primary key at the normal downstop position at the end of the reset cycle does not block latching of the trip arm. During the reset cycle the trip arm moves the nonrepeat lever upward into the cutout area of the latchlever. When the trip arm is moved downward at the end of the reset cycle, the latchlever spring rotates the latchlever counterclockwise over the trip arm.

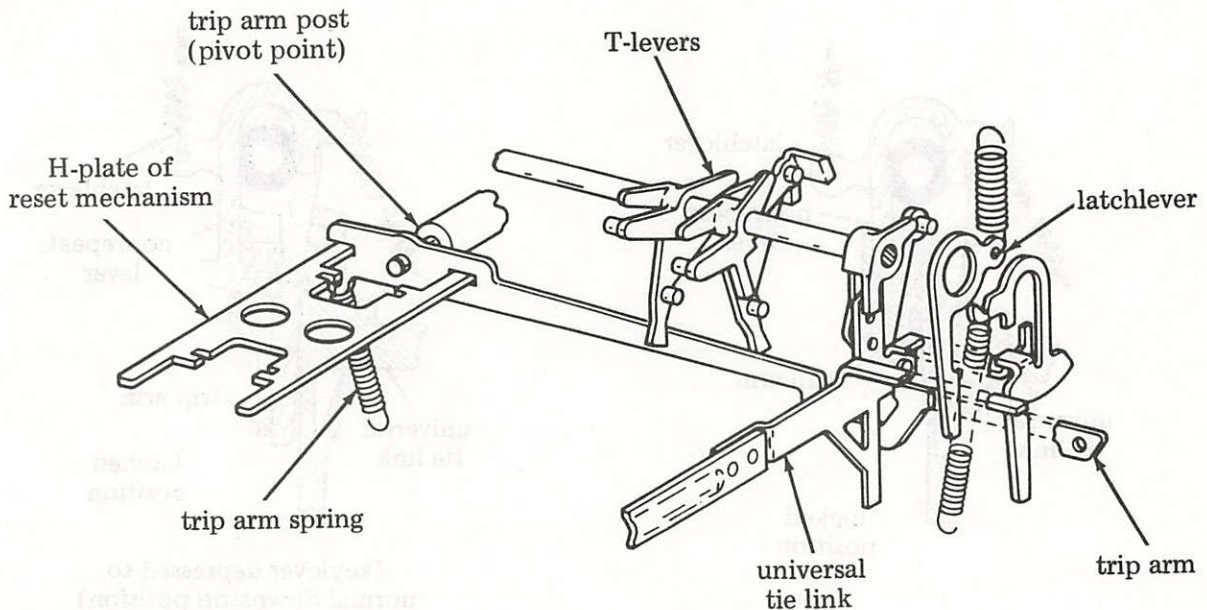

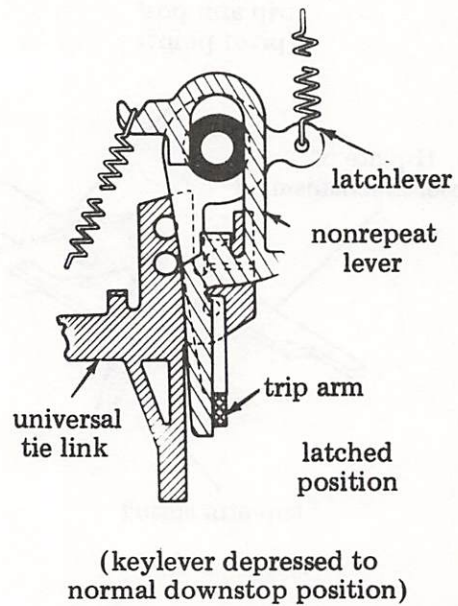
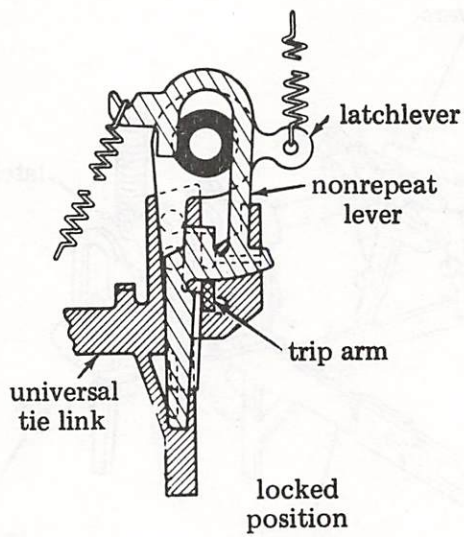
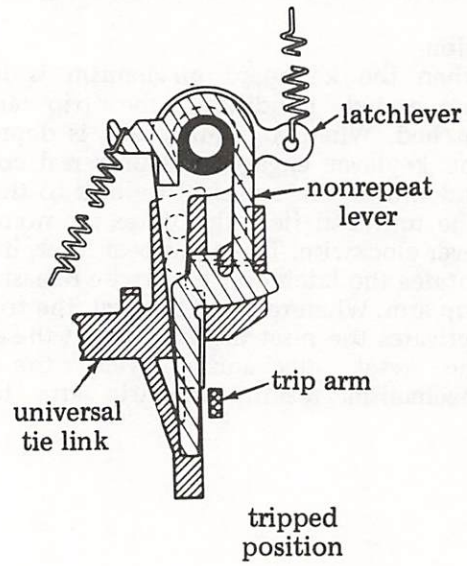
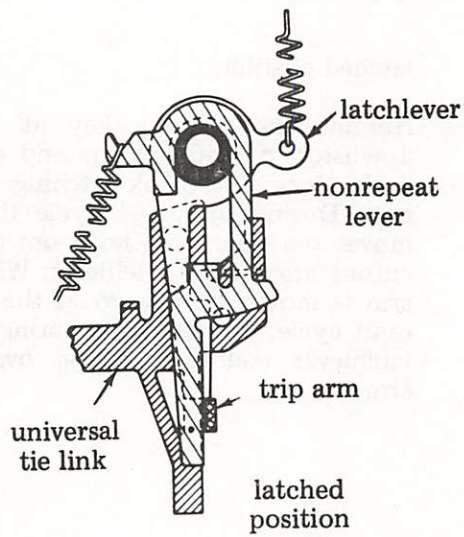

REPEAT MECHANISM

Purpose.

Blocks latching of trip arm when primary key is held depressed beyond normal downstop position, permitting repeat of character until primary key is released.

Operation

A keylever, not stopped by a downstop blocking clip, is stopped by the downstop bar when depressed by using normal finger pressure. Depressing the key further downward, on the spring-biased downstop bar, causes the universal codebar to move further downward. This moves the universal tie link further to the left. The nonrepeat lever strikes the vertical tab on universal tie link and is pressed against the latchlever. This prevents the latchlever from returning to the latched position when the trip arm is reset. The trip arm, not being latched again raises and activates the reset mechanism. This

action continues until the keylever is returned to the normal downstop position or released. When the keylever returns to the normal downstop position or is released, the nonrepeat lever does not block the return of the latchlever to its latching position and the repeat action is stopped.

Downstop blocking clips, which attach to the front keylever slots in the frame, block the downward movement of selected keylevers beyond the normal downstop position. Keylevers so blocked become non-repeatable.

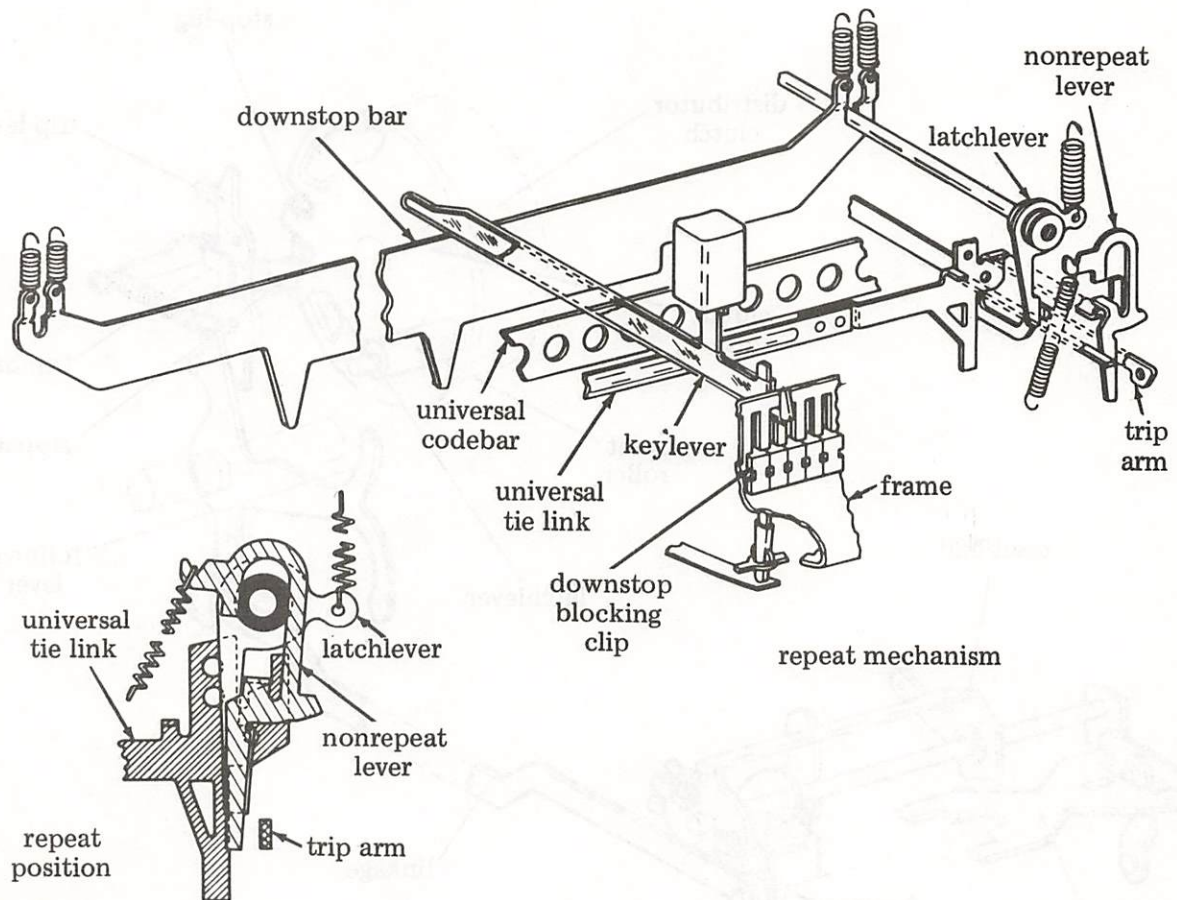

TRIP ARM RESET

Purpose

Resets trip arm mechanism after a primary key has been depressed to permit subsequent key to be depressed.

Operation

When the trip arm is released and travels upward, its extension beyond the pivot point moves downward applying a clockwise rotational motion to the reset mechanism H-plate. The H-plate transfers the pivoting motion through the reset bail and linkage to the distributor clutch stop arm. The clutch stop arm, which is spring biased inward, is moved outward releasing the clutch latch-
 lever. The clutch then disengages the clutch drum and the intermediate gear mechanism that drives the distributor through one cycle of operation. (As the clutch is a one-stop mechanism, 360 degree rotation of the clutch provides one cycle of operation.) During three-fourths of the cycle, 270

degrees, the H-plate does not move leaving the keyboard trip arm unlatched allowing the code to be processed by the distributor. At the beginning of the last one-fourth of the clutch cycle, the reset roller on the clutch disc engages the follower lever which through the linkage and reset bail pivots the H-plate counterclockwise. This action moves the keyboard trip arm downward to the latched position. The latched position of the keyboard trip arm holds the clutch stop arm in position to meet the latchlever at the end of the clutch cycle. Shortly after the keyboard trip arm is latched the distributor clutch latches and the keyboard and distributor are ready to process the next function or character.

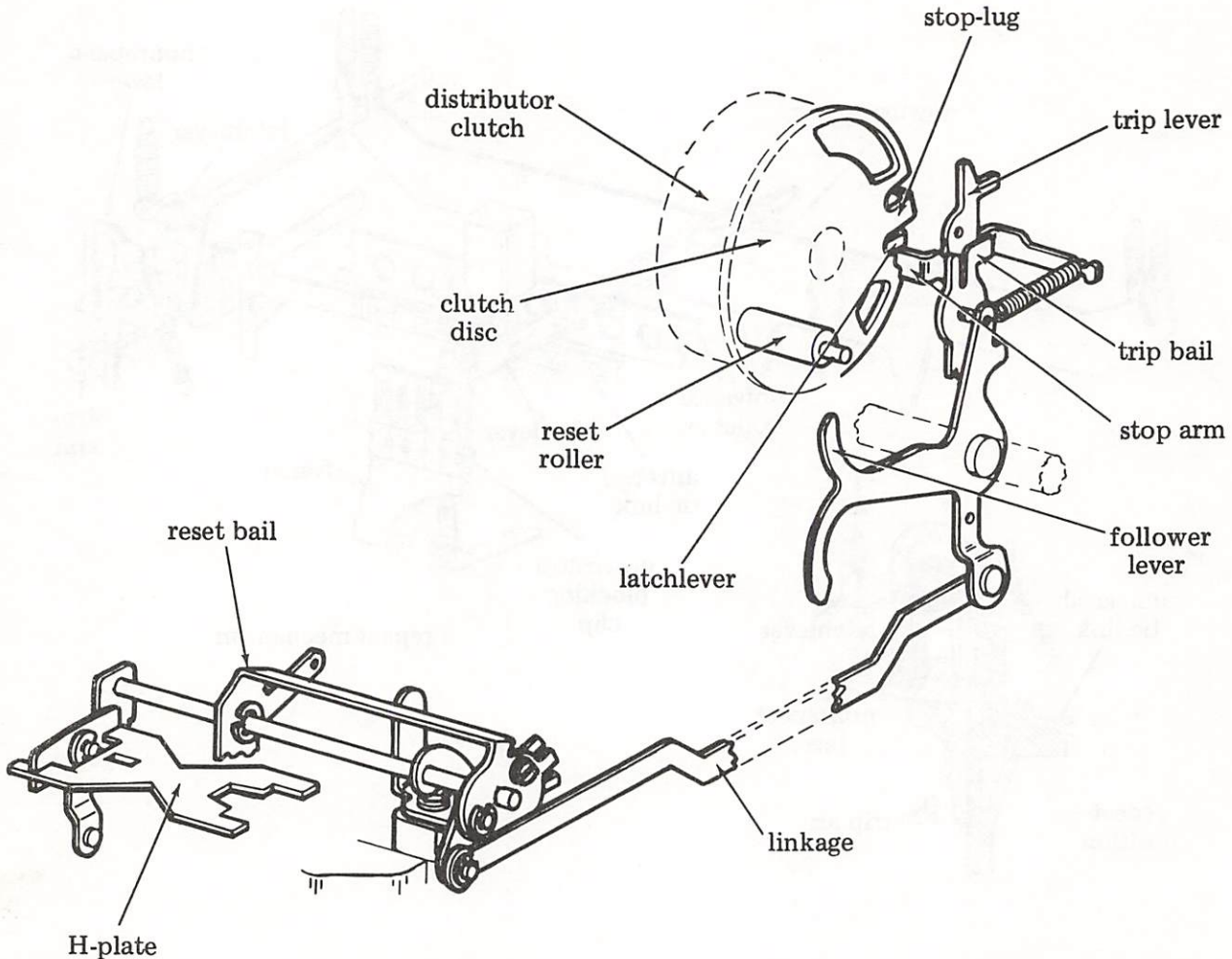

ELECTRICAL OPERATION

3.14 Keyboard Output

- (1) The output of the keyboard consists of eleven leads or circuit paths through the keyboard contact mechanism. This output is applied to the logic card to generate the 128 characters and controls.
- (2) As shown in the schematic diagram, the outputs are associated with specific codebars. The keys initiating the positioning of the codebars and the resulting contact operations affect the output as follows:
 - (a) Keyboard outputs 1 through 7 and parity occur when any key with the exception of SHIFT and/or CONTRL is depressed.
 - (b) The control and shift outputs occur when the CONTRL and SHIFT keys, respectively, are depressed.
 - (c) The shift inhibit output occurs when a key associated with only one character or control is depressed together with or independent of the SHIFT or CONTRL keys.
- (3) When a key is depressed alone or with the SHIFT or CONTRL key, the keyboard output is developed as follows:

- (a) Outputs 1 through 7 occur as binary state 1 or 0 according to the ASCII code for the character or control corresponding to the use of that key alone. For example, the binary state for outputs 1 through 7 is the same for the character A whether a lower or upper case A is entered into the keyboard.
- (b) The parity output state is binary 1 or 0 as determined by the total number of 1s in outputs 1 through 7. This output will be 1 or 0 to provide an even number of 1s in outputs 1 through 8.
- (c) The control output state is a binary 1 or 0 depending on whether the CONTRL key is depressed.
- (d) The shift output state is a binary 1 or 0 depending on whether the SHIFT key is depressed.
- (e) The shift inhibit output is binary state 1 if the depressed key can be used only to generate one character or one control.

3.15 Keyboard Logic — The keyboard logic output is in the form of bit permutations. Bits 1 through 7 are binary state 1 or 0 according to the character or control entered into the keyboard, and the parity bit is 1 or 0 to provide even parity.

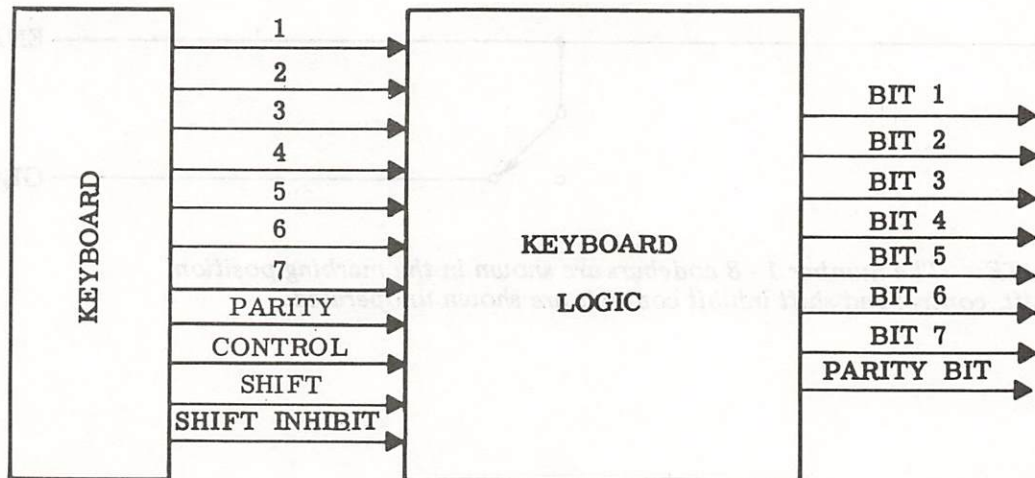

KEYBOARD SCHEMATIC DIAGRAM

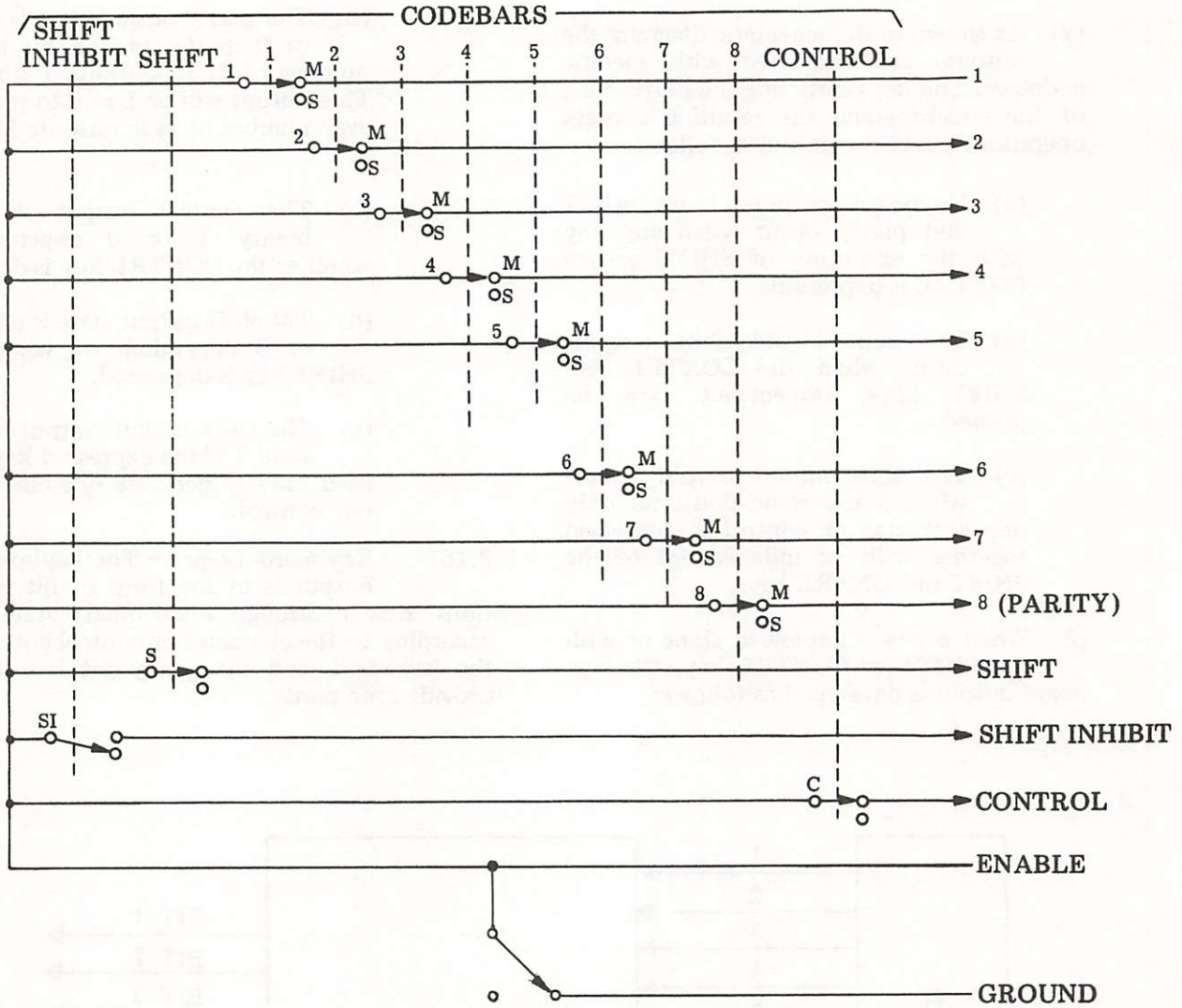

NOTE: The number 1 - 8 codebars are shown in the marking position. Shift, control and shift inhibit contacts are shown unoperated.

ASCII CHART

| BITS | | | | 0 | | | | 1 | | | | | | | |
|------|---|---|---|-----|-----|----|---|---|---|---|-----|--|--|--|--|
| | | | | 0 | | 1 | | 0 | | 1 | | | | | |
| | | | | 0 | 1 | 0 | 1 | 0 | 1 | 0 | 1 | | | | |
| 4 | 3 | 2 | 1 | | | | | | | | | | | | |
| 0 | 0 | 0 | 0 | NUL | DLE | SP | 0 | @ | P | \ | p | | | | |
| | | | 1 | SOH | DC1 | ! | 1 | A | Q | a | q | | | | |
| | | 1 | 0 | STX | DC2 | " | 2 | B | R | b | r | | | | |
| | | | 1 | ETX | DC3 | # | 3 | C | S | c | s | | | | |
| | 1 | 0 | 0 | EOT | DC4 | \$ | 4 | D | T | d | t | | | | |
| | | | 1 | ENQ | NAK | % | 5 | E | U | e | u | | | | |
| | | 1 | 0 | ACK | SYN | & | 6 | F | V | f | v | | | | |
| | | | 1 | BEL | ETB | ' | 7 | G | W | g | w | | | | |
| 1 | 0 | 0 | 0 | BS | CAN | (| 8 | H | X | h | x | | | | |
| | | | 1 | HT | EM |) | 9 | I | Y | i | y | | | | |
| | | 1 | 0 | LF | SUB | * | : | J | Z | j | z | | | | |
| | | | 1 | VT | ESC | + | ; | K | [| k | { | | | | |
| | 1 | 0 | 0 | FF | FS | , | < | L | \ | l | | | | | |
| | | | 1 | CR | GS | - | = | M |] | m | } | | | | |
| | | 1 | 0 | SO | RS | . | > | N | ^ | n | ~ | | | | |
| | | | 1 | SI | US | / | ? | O | _ | o | DEL | | | | |

Characters and controls are generated by use of a key alone (), with a SHIFT key (), or with a CONTRL key (). See Figure 5.

CODE STRUCTURE - 8-LEVEL 11-UNIT CODE
 (dc neutral signal is illustrated)

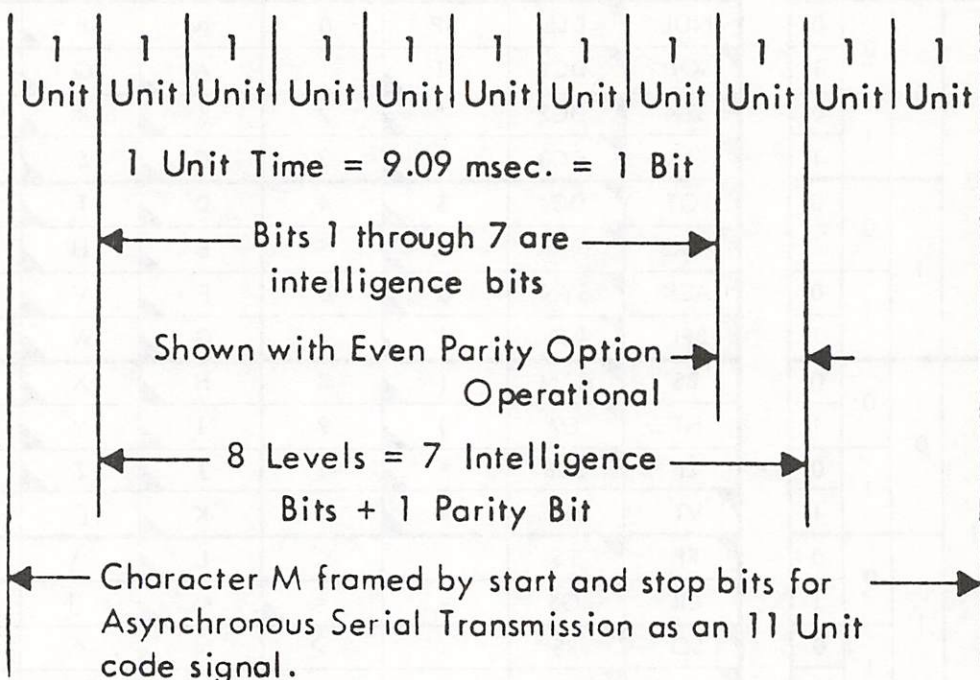
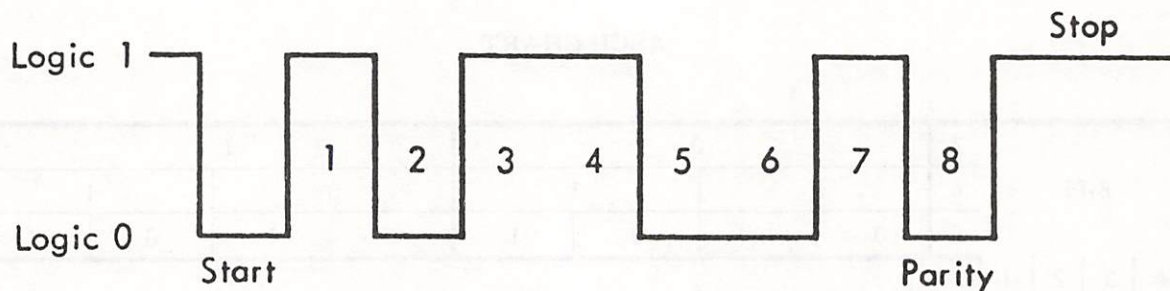

Mark-Logic 1 (Current) Space-Logic 0 (No Current)

4. KEYBOARD FOR APL SETS

4.01 The keyboard used on APL (A Programming Language) sets is mechanically similar to the standard keyboard described in this section. It is different in a number of ways. The 8th bit always marking option available on the standard keyboards is not available on the APL keyboard. Figure 11 shows the APL keyboard layout with the matching type wheel character layout.

4.02 Figure 12 shows the code assignment for the characters generated by the APL keyboard. Characters in the shaded areas are

ASCII designations. All other characters are APL designations.

4.03 Figure 13 shows the character designations and definitions for the distinct APL characters.

4.04 Distinct overstrike APL symbols are generated on the keyboard in three steps. The operator generates a primary symbol, backspaces, and then generates the overstrike symbol. Figure 14 shows the overstrike symbols.

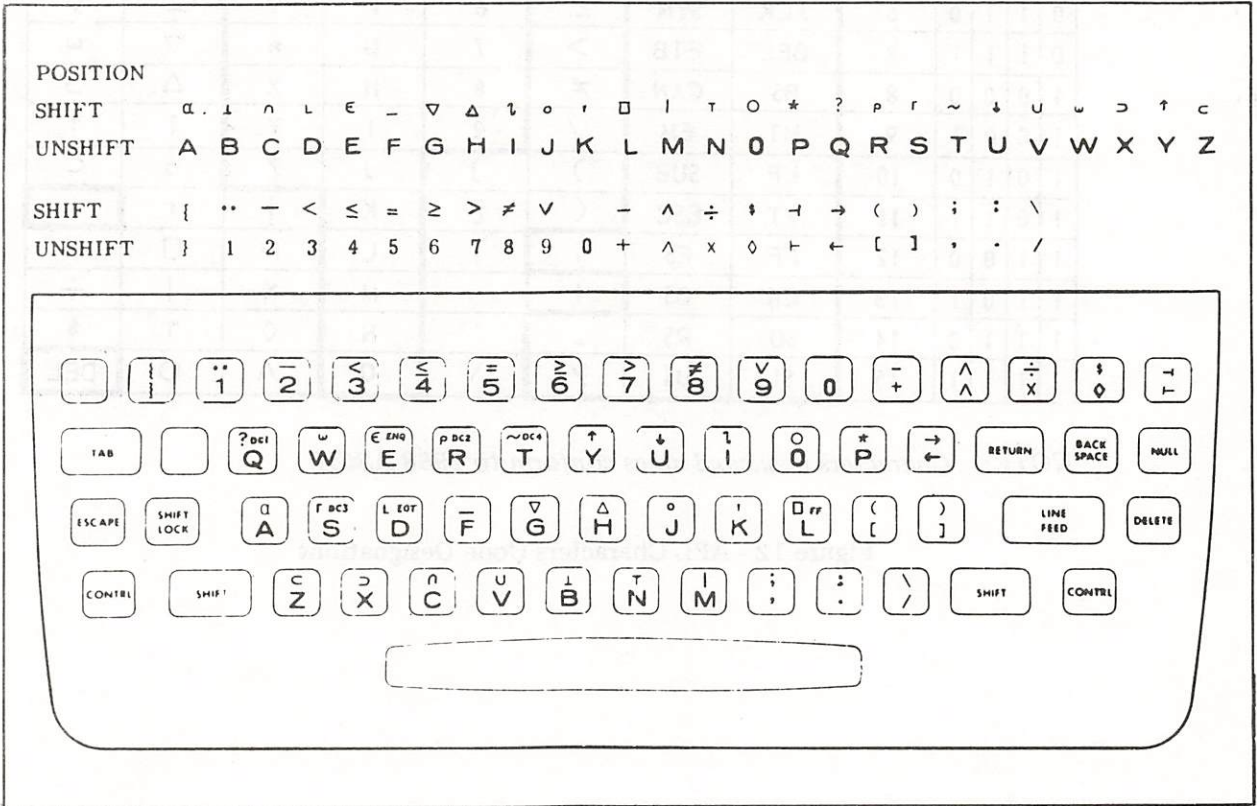

Figure 11 - APL Keyboard and Type Wheel Layout

| Bits | | | | | 0 0 | 0 0 1 | 0 1 0 | 0 1 1 | 1 0 0 | 1 0 1 | 1 1 0 | 1 1 1 | | | | |
|----------------|----------------|----------------|----------------|----------------|----------------|----------------|--------|-------|-------|-------|-------|-------|---|-----|---|---|
| b ₇ | b ₆ | b ₅ | b ₄ | b ₃ | b ₂ | b ₁ | COLUMN | ROW | 0 | 1 | 2 | 3 | 4 | 5 | 6 | 7 |
| 0 | 0 | 0 | 0 | 0 | 0 | 0 | NUL | DLE | SP | 0 | ← | P | → | * | | |
| 0 | 0 | 0 | 0 | 1 | 1 | 1 | SOH | DC1 | °° | 1 | A | Q | Q | ? | | |
| 0 | 0 | 1 | 0 | 0 | 2 | 2 | STX | DC2 | — | 2 | B | R | ⊥ | P | | |
| 0 | 0 | 1 | 1 | 0 | 3 | 3 | ETX | DC3 | < | 3 | C | S | ∩ | ∩ | | |
| 0 | 1 | 0 | 0 | 0 | 4 | 4 | EOT | DC4 | ≤ | 4 | D | T | L | ~ | | |
| 0 | 1 | 0 | 1 | 0 | 5 | 5 | ENQ | NAK | = | 5 | E | U | € | ↓ | | |
| 0 | 1 | 1 | 0 | 0 | 6 | 6 | ACK | SYN | ≥ | 6 | F | V | — | U | | |
| 0 | 1 | 1 | 1 | 0 | 7 | 7 | BEL | ETB | > | 7 | G | W | ∇ | e | | |
| 1 | 0 | 0 | 0 | 0 | 8 | 8 | BS | CAN | ≠ | 8 | H | X | Δ | ∩ | | |
| 1 | 0 | 0 | 1 | 0 | 9 | 9 | HT | EM | √ | 9 | I | Y | ∩ | ↑ | | |
| 1 | 0 | 1 | 0 | 0 | 10 | 10 | LF | SUB |) |] | J | Z | o | c | | |
| 1 | 0 | 1 | 1 | 0 | 11 | 11 | VT | ESC | (| [| K | } | ∩ | } | | |
| 1 | 1 | 0 | 0 | 0 | 12 | 12 | FF | FS | , | ; | L | ∩ | ∩ | ∩ | | |
| 1 | 1 | 0 | 1 | 0 | 13 | 13 | CR | GS | + | — | M | X | | ÷ | | |
| 1 | 1 | 1 | 0 | 0 | 14 | 14 | SO | RS | . | : | N | ∩ | T | ∩ | | |
| 1 | 1 | 1 | 1 | 0 | 15 | 15 | SI | US | / | \ | O | ∩ | O | DEL | | |

NOTE: Characters in shaded areas conform to 1968 ASCII.

Figure 12 - APL Characters Code Designations

| APL SYMBOL | DESCRIPTION | APL SYMBOL | DESCRIPTION |
|------------|--------------------------|------------|---------------------------|
| ¨ | UMLAUT OR DIAERESIS | α | ALPHA |
| - | NEGATIVE | ⌈ | CEILING OR MAXIMUM |
| < | LESS THAN | ⌋ | FLOOR OR MINIMUM |
| ≤ | LESS THAN OR EQUAL TO | ¯ | UNDERLINE |
| = | EQUAL | ∇ | DEL |
| ≥ | GREATER THAN OR EQUAL TO | Δ | DELTA |
| > | GREATER THAN | ° | DEGREE (SMALL CIRCLE) |
| ≠ | NOT EQUAL | ' | QUOTE |
| ∨ | OR | □ | QUAD |
| ∧ | AND | (| PARENTHESIS |
| - | MINUS |) | PARENTHESIS |
| ÷ | DIVISION | [| BRACKET |
| + | PLUS |] | BRACKET |
| x | TIMES | | |
| ? | ROLL | ⊂ | UNNAMED |
| ω | OMEGA | ⊃ | UNNAMED |
| ε | ELEMENT | ∩ | UNNAMED |
| ρ | RHO | ∪ | UNNAMED |
| ~ | NOT | ⊥ | DECODE |
| ↑ | TAKE | ⊤ | ENCODE |
| ↓ | DROP | | ABSOLUTE VALUE OR RESIDUE |
| ι | IOTA | ; | SEMICOLON |
| ο | PI TIMES | , | CATENATION |
| * | EXPONENT | : | COLON |
| → | BRANCH | . | DECIMAL |
| ← | ASSIGN | \ | LEFT SLASH |
| ⊔ | UNNAMED | / | RIGHT SLASH |
| ⊖ | UNNAMED | | |

Figure 13 - APL Characters and Definitions

| COMPLETED SYMBOL | DESCRIPTION | PRIMARY SYMBOL | | OVER-STRIKE SYMBOL |
|------------------|------------------------------------|----------------|-------------------------------------------|--------------------|
| ⊗ | LOGARITHM | ○ | B A C K S P A C E | * |
| ⊘ | REVERSAL OR ROTATE | ○ | | |
| ⊙ | TRANSPOSE | ○ | | \ |
| ⊠ | GRADE UP | Δ | | |
| ⊡ | GRADE DOWN | ∇ | | |
| ⊢ | COMMENT OR LAMP | ∩ | | ○ |
| ⊣ | QUOTE QUAD | ' | | □ |
| ⊤ | FACTORIAL COMBINATION | ! | | . |
| ⊥ | NAND | ∧ | | ~ |
| ⊦ | NOR | ∨ | | ~ |
| ⊧ | DEL TILDE | ∇ | | ~ |
| ⊨ | I BEAM | ⊤ | | ⊥ |
| ⊩ | UNNAMED | ⊤ | | ⊥ |
| ⊪ | "ANY ST'D. SCALAR DYADIC OPERATOR" | ○ | | ° |

Figure 14 - APL Overstrike Symbols

38 KEYBOARD

LUBRICATION

| CONTENTS | PAGE |
|-----------------------------------|------|
| 1. GENERAL | 1 |
| 2. KEYBOARD | 2 |
| Codebar sets | 2 |
| Contact wires | 6 |
| Downstop bar | 3 |
| Keylevers | 3 |
| Spacebar and space bail | 4 |
| Trip arm lever | 6 |
| Universal codebar | 5 |

operation, relubricate keyboard. Thereafter, lubricate every 750 operating hours or six months, whichever occurs first.

CAUTION: DISCONNECT POWER BEFORE APPLYING ANY LUBRICANT. DO NOT USE SOLVENTS TO CLEAN PLASTIC PARTS OR PROTECTIVE FINISHES. USE A SOFT DRY CLOTH. IF NECESSARY, USE A SOFT DAMP CLOTH WITH MILD DETERGENT, THEN RINSE AND BUFF WITH A SOFT DRY CLOTH.

1. GENERAL

1.01 This section provides lubrication procedures for the Model 38 Keyboard. It is reissued to change the lubrication interval. To remove the keyboard as a unit from the teletypewriter, refer to Section 574-400-702TC.

1.02 A photograph shows numbered callouts which correspond to a paragraph containing a line drawing. The line drawing shows the specific points of each mechanism to be lubricated.

1.03 References to front, rear, left, right, etc, are made viewing the keyboard from its normal operating position.

1.04 Lubricate the keyboard before placing it in service, and just before placing it in storage. After about 100 to 200 hours of

1.05 The following symbols, and their meaning, apply to the lubrication points specified in each paragraph:

| <u>SYMBOL</u> | <u>MEANING</u> |
|---------------|----------------------------------------------------|
| D | Dry — no lubricant permitted |
| G | Grease — apply KS7471 grease as instructed |
| L | Lubriplate — apply TKS102 Lubriplate as instructed |
| O | Oil — apply KS7470 oil as instructed |

1.06 In general, apply oil in such places where parts rub, slide, or move with respect to each other. Apply oil to points where it will adhere and not run off. Avoid overlubrication. Keep electrical contacts and wire insulations free of lubricants.

2. KEYBOARD

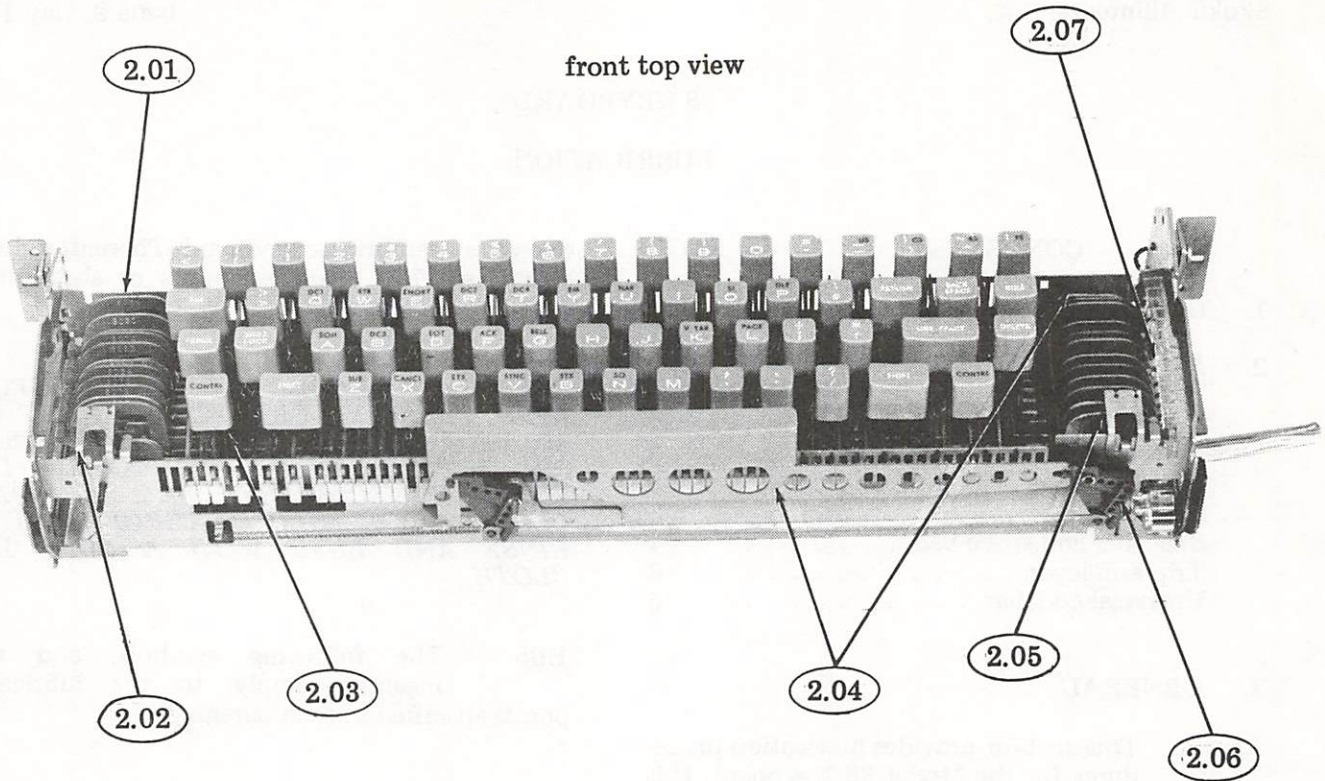

2.01 Codebar Sets

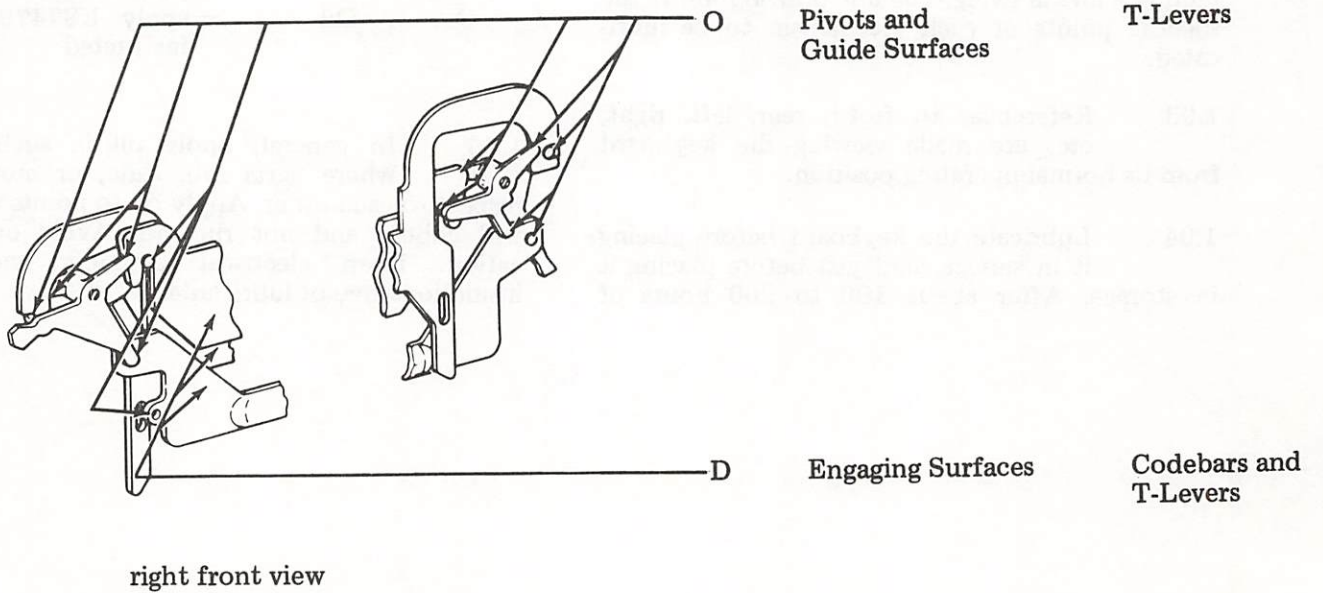

2.02 Downstop Bar

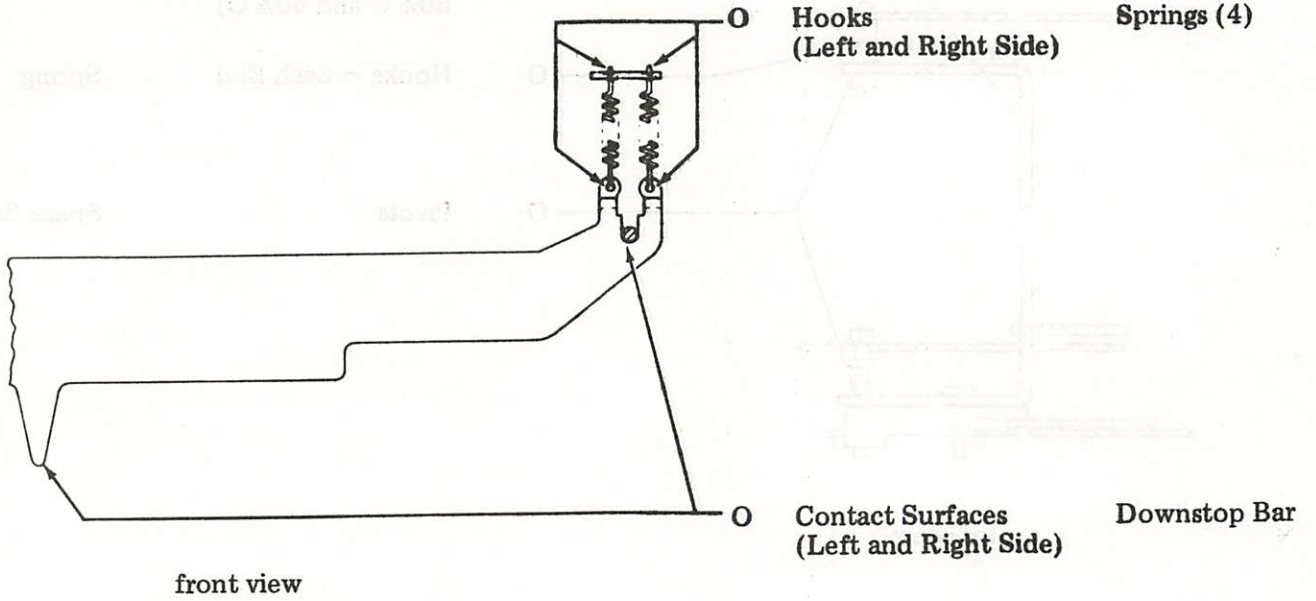

2.03 Keylevers

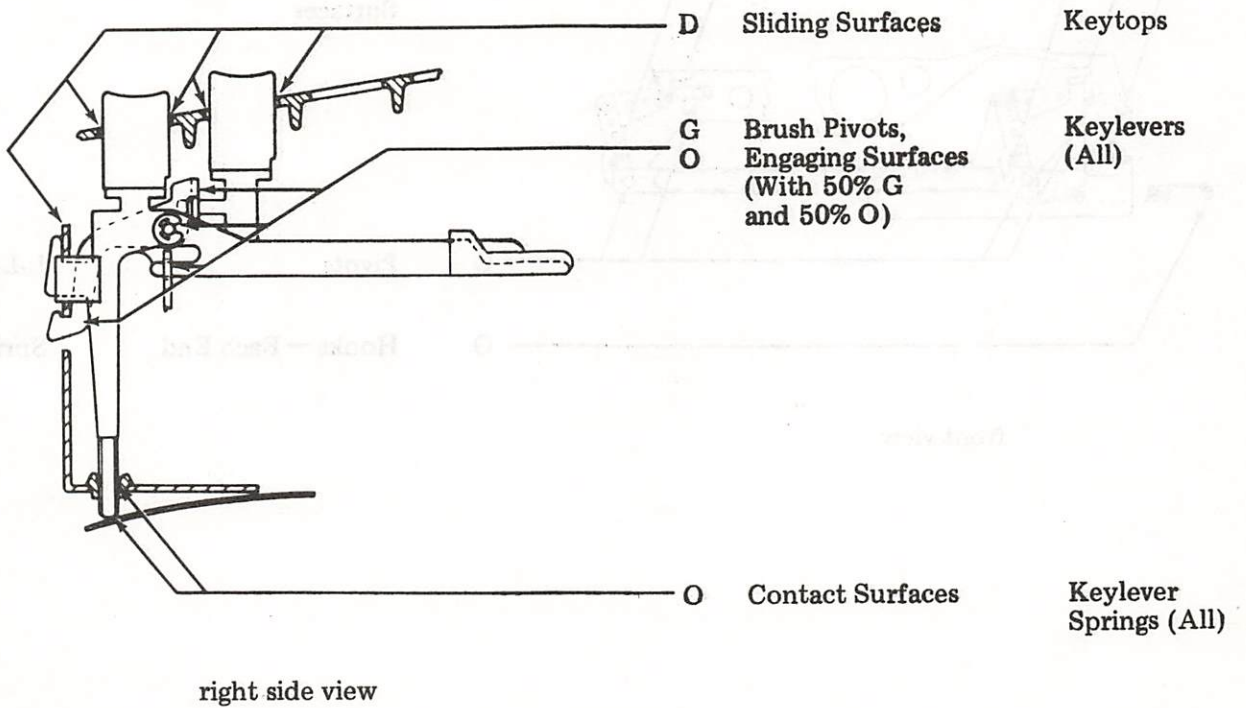

2.04 Spacebar and Space Bail

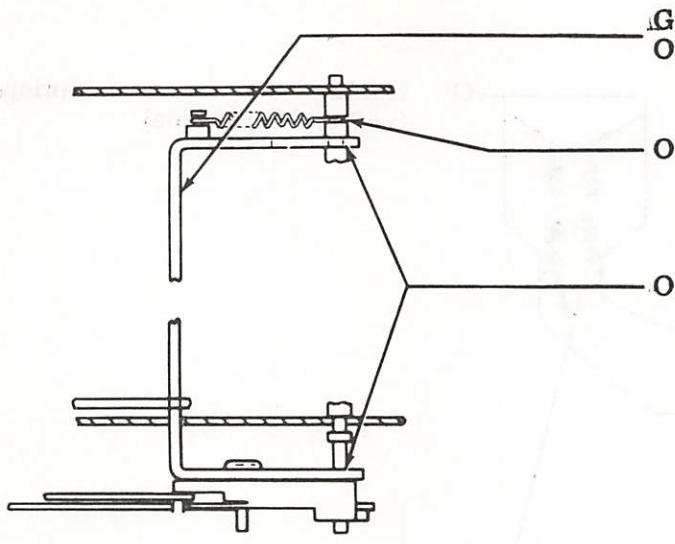

top view

- G O Brush Contact Surface (With thin coat 50% G and 50% O) Space Bail
- O Hooks — Each End Spring
- O Pivots Space Bail

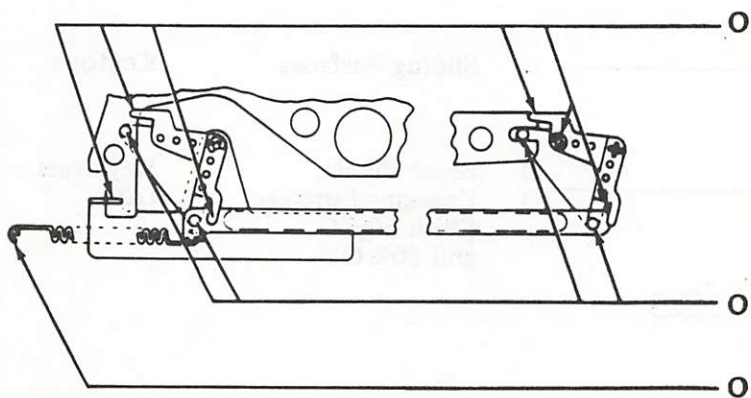

front view

- O Pivots and Guide Surfaces L-Levers
- O Pivots L-Levers
- O Hooks — Each End Spring

2.05 Universal Codebar

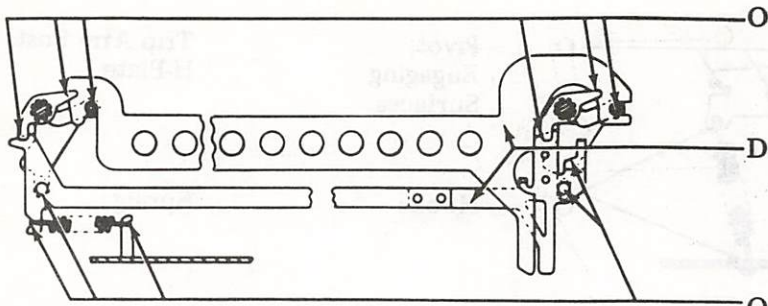

Pivots and Guide Surfaces

T-Levers

Surfaces (Both Sides)

Codebar, Tie Link

Engaging Surface, Pivots, Hooks

Tie Link, T-Levers, Spring

front view

front view

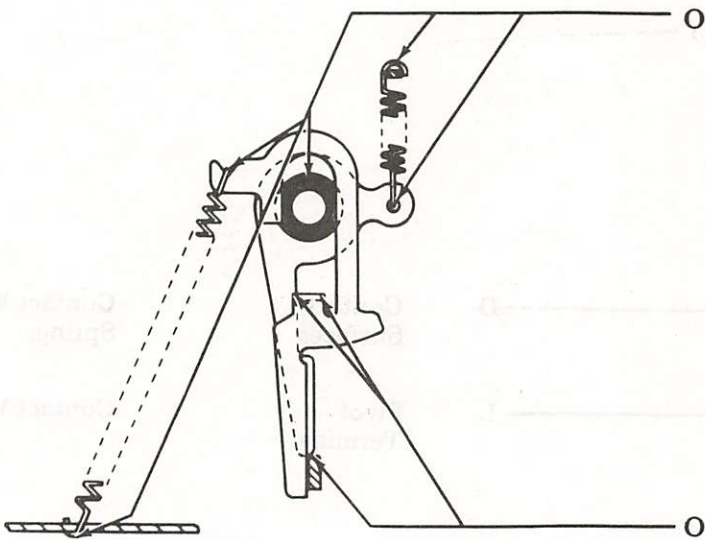

Hooks, Pivots

Springs, Latchlever, Nonrepeat Lever

Engaging Surfaces

Latchlever, Nonrepeat Lever

2.06 Trip Arm Lever

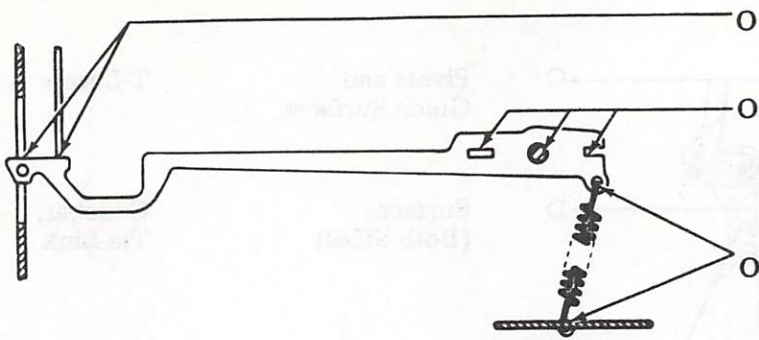

- O Engaging Surface Trip Arm
- O Pivot, Engaging Surfaces Trip Arm Post, H-Plate
- O Hooks Spring

right side view

2.07 Contact Wires

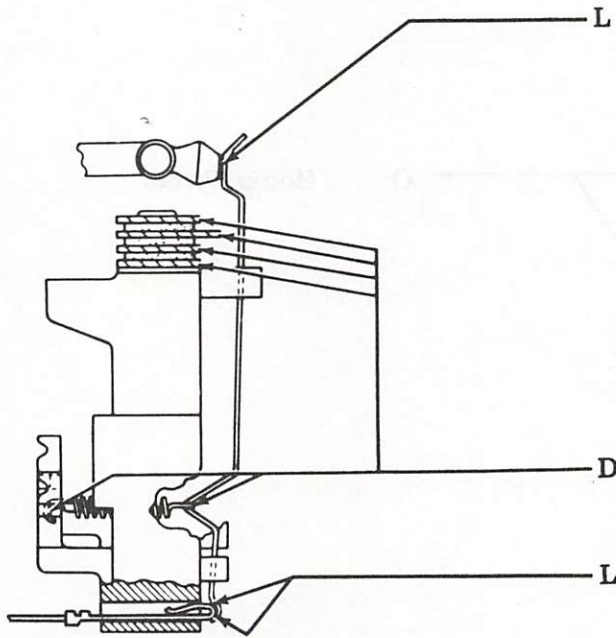

- L Thin coat on engaging surface on disassembly and reassembly of contact mechanism T-Levers
- D Contact Surfaces Contact Wires, Springs
- L Pivot Terminal Contact Wires

right front view

38 KEYBOARD

DISASSEMBLY AND REASSEMBLY

| CONTENTS | PAGE |
|----------------------------------|------|
| 1. GENERAL | 1 |
| 2. KEYBOARD | 1 |
| KEYTOP GUIDE | 1 |
| KEYLEVERS AND KEYTOPS . . . | 2 |
| CONTACT BLOCK ASSEMBLY | 2 |

1. GENERAL

1.01 This section provides disassembly and reassembly instructions for the 38 Keyboard. These instructions are confined to major subassemblies only. If further keyboard disassembly and reassembly is required, refer to Section 574-421-800TC.

1.02 To remove the keyboard as a unit from the teletypewriter, refer to Section 574-400-702TC.

2. KEYBOARD

KEYTOP GUIDE

2.01 Disassemble keytop guide (Figure 1) as follows:

- (a) Remove LOCAL RETURN and PAPER ADVANCE pushbutton knobs.
- (b) Pull tab at front of keytop guide forward, until it is disengaged from post on front of keyboard.
- (c) Rotate keytop guide toward rear and up over keytops.
- (d) Remove keytop guide from keyboard.

2.02 Reassemble keytop guide by reversing procedure in 2.01.

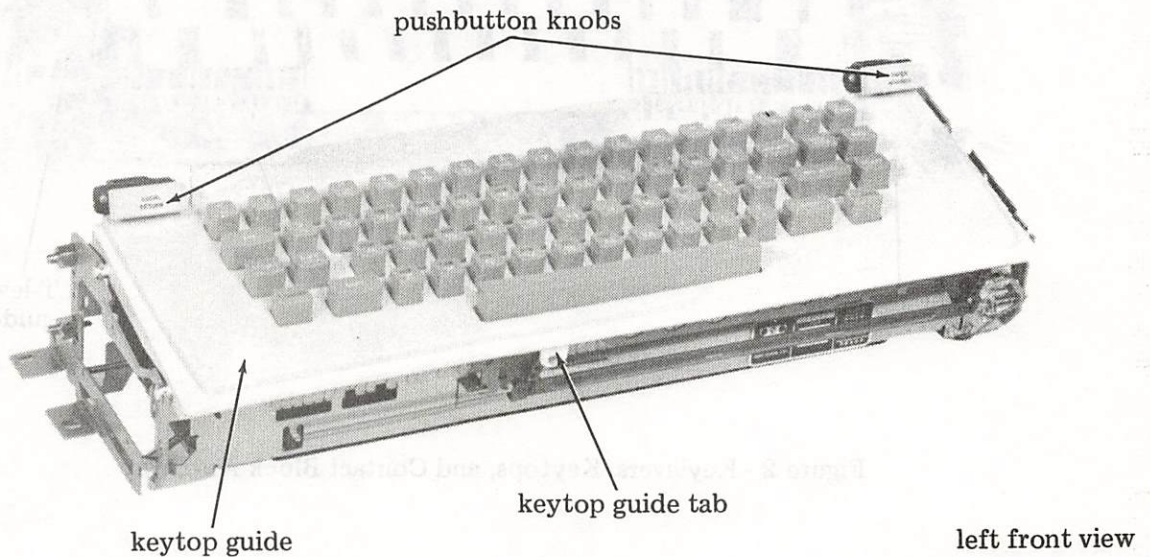

Figure 1 - Keytop Guide

KEYLEVERS AND KEYTOPS

2.03 Disassemble keylevers and keytops (Figure 2) as follows:

NOTE: Remove SHIFT or CONTRL keylever springs from end brackets before removing keys.

- (a) Remove keytop guide as outlined in 2.01.
- (b) Remove keylevers as required.
- (c) Remove keytops as required.

2.04 Reassemble keylevers and keytops by reversing procedure in 2.03.

CONTACT BLOCK ASSEMBLY

2.05 Disassemble contact block assembly (Figure 2) as follows:

(a) Remove trip arm spring.

(b) Remove right end bracket assembly by lightly squeezing against frame at rear assembly area.

(c) Remove left end bracket assembly by lightly squeezing against frame at rear assembly area.

(d) Remove two compression springs from contact block.

(e) Remove T-lever guides at right side of keyboard.

(f) Remove contact wires by detaching their springs.

2.06 Reassemble contact block assembly by reversing procedure in 2.05.

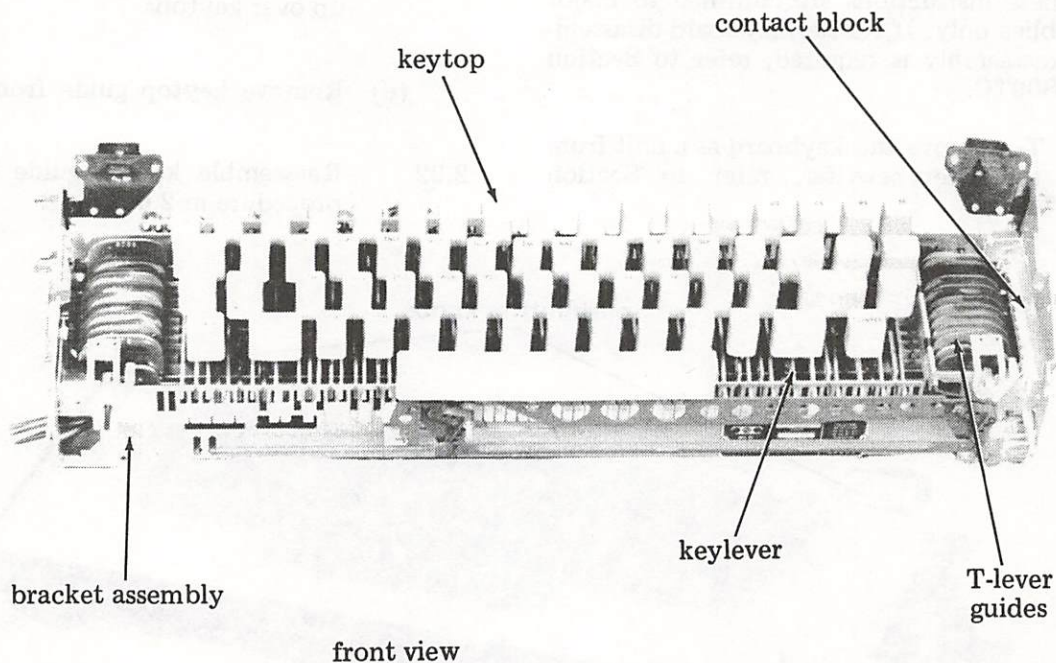

Figure 2 - Keylevers, Keytops, and Contact Block Assembly

38 TYPING UNIT

DESCRIPTION AND PRINCIPLES OF OPERATION

| CONTENTS | PAGE | | PAGE |
|---------------------------------------|------|---------------------------------------------|------|
| 1. GENERAL | 2 | B. Remote Actuation | 12 |
| 2. TECHNICAL DATA | 2 | C. Automatic Actuation | 13 |
| DIMENSIONS AND WEIGHT | 2 | D. Local Actuation | 14 |
| ELECTRICAL REQUIREMENTS | 2 | MOTOR AND DRIVE MECHANISMS | 16 |
| MOTIVE POWER | 3 | A. Motor and Intermediate Gearing | 16 |
| SPEED OF OPERATION | 3 | B. Main Shaft | 17 |
| PAPER AND FORM REQUIREMENTS | 3 | C. Clutches | 17 |
| SIGNAL CODE | 3 | SELECTOR MECHANISM | 18 |
| 3. DESCRIPTION | 5 | RANGE FINDER | 20 |
| DISTRIBUTOR | 5 | CODEBAR MECHANISM | 21 |
| ANSWER-BACK MECHANISM | 5 | FUNCTION MECHANISM | 23 |
| MOTOR AND DRIVE MECHANISMS | 6 | PRINTING MECHANISM | 24 |
| SELECTOR MECHANISM | 6 | A. Type Wheel | 24 |
| CODEBAR MECHANISM | 6 | B. Motive Force | 24 |
| FUNCTION MECHANISM | 6 | C. Rotary Positioning | 24 |
| PRINTING MECHANISM | 8 | D. Degree of Rotation | 25 |
| 4. PRINCIPLES OF OPERATION | 9 | E. Vertical Positioning | 26 |
| DISTRIBUTOR | 9 | F. Printing Mechanism | 29 |
| A. General | 9 | G. Printing Suppressed | 30 |
| B. Operation | 9 | H. Ribbon Mechanism | 31 |
| ANSWER-BACK MECHANISM | 11 | I. Two-Color Printing | 32 |
| A. Answer-Back Drum | 11 | SPACING MECHANISM | 33 |
| | | SPACE SUPPRESSION | 34 |
| | | CARRIAGE RETURN | 35 |
| | | PAPER OR FORM FEEDING | 36 |
| | | A. Friction Feed | 36 |
| | | B. Sprocket Feed | 36 |
| | | MARGIN BELL AND END-OF-LINE BELL | 41 |
| | | A. Margin Bell | 41 |
| | | B. End-of-Line Bell | 41 |
| | | BACKSPACE MECHANISM | 41 ← |

CONTENTS

PAGE

5. OPTIONS 42

AUTOMATIC CARRIAGE
RETURN/LINE FEED 42

1. GENERAL

1.01 This section provides the description and principles of operation for the 38 typing unit (Figure 1). The 38 typing unit is an electromechanical device which prints graphics on a paper copy according to a code, and performs nonprinting functions. It is reissued to make some corrections and to add a description of the backspace mechanism used on APL sets. Marginal arrows indicate the changes and additions.

1.02 In the illustrations, fixed pivot points are shown solid black, and floating pivot points (those mounted on parts that move) are shown crosshatched.

1.03 References to right or left, front or rear, consider the typing unit as viewed by the operator with the printing mechanism in the front, and the distributor on the right side toward the rear.

2. TECHNICAL DATA

2.01 Some of the data that follows is approximate. Also, the dimensions and weight given for the typing unit are for a standard unit, less options.

2.02 This equipment is intended to be operated in a room environment within the temperature range of 40°F to 110°F. Serious damage to it could result if this range is exceeded. In this connection, particular caution should be exercised in using acoustical or other enclosures.

DIMENSIONS AND WEIGHT

2.03 The physical dimensions and weight of the 38 typing unit are as follows:

- Width 19 inches
- Depth 13-1/2 inches
- Height 8 inches
- Weight 35 pounds

ELECTRICAL REQUIREMENTS

2.04 In addition to the following data, a convenience outlet is provided in the electrical service unit (part of the set) which permits up to 100 watts of additional load.

Input Voltages

- 115 v ac $\pm 10\%$, 60 Hz ± 0.5 Hz, single phase
- 115 v ac $\pm 10\%$, 50 Hz ± 0.5 Hz, single phase

Operating Margins (All signal contacts and distributor)

Long telegraph loops

- 0.015 to 0.070 amp at 48 to 240 volts dc inductive

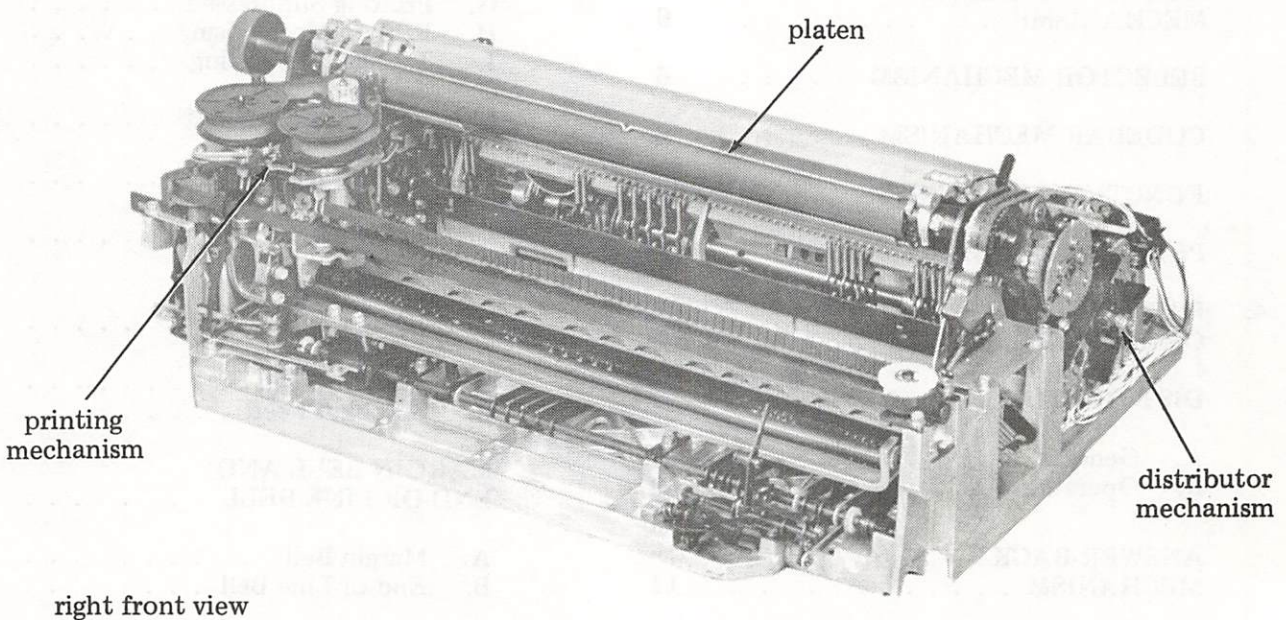

Figure 1 - 38 Typing Unit

Short telegraph loops

- 0.58 to 0.72 amp at 16 to 22 volts dc resistive

MOTIVE POWER

2.05 Three types of motors are available for use in the 38 typing unit. The three types, with specifications, are as follows:

Motor 181870

Type

- Synchronous, capacitor start

Input

- 115 v ac $\pm 10\%$, 60 Hz, single phase

Input current

- 2 amperes

Output

- 33 millihorsepower

Speed

- 3600 rpm

Temperature rating

- 130° C

Power factor

- 40%

Motor 182241

Type

- Synchronous, capacitor start and run

Input

- 115 v ac $\pm 10\%$, 60 Hz, single phase

Input current

- 1.6 ampere

Output

- 33 millihorsepower

Speed

- 3600 rpm

Temperature rating

- 130° C

Power factor

- 40%

Motor 182267

Type

- Synchronous, capacitor start and run

Input

- 115 v ac $\pm 10\%$, 50 Hz, single phase

Input current

- 1.7 ampere

Output

- 35 millihorsepower

Speed

- 3000 rpm

Temperature rating

- 130° C

Power factor

- 40%

SPEED OF OPERATION

2.06 The 38 typing unit is capable of operating at 60, 66, 75, or 100 words per minute. The standard unit, as shipped from the factory, operates at 100 words per minute. Conversion from one speed to another is accomplished by changing the intermediate gear with pulley, and readjusting the motor unit.

PAPER AND FORM REQUIREMENTS

2.07 Both wide and standard platen printers are available. The wide platen printer is available only in sprocket feed. The standard platen is available in sprocket feed and friction feed. In addition, a modification kit is available which will convert a wide platen sprocket feed to a standard platen friction feed.

- Wide Platen, Sprocket Feed: This printer accepts 14-7/8 inch continuous sprocket feed forms with a maximum line capacity of 132 characters at 10 characters per inch horizontal spacing.

- Standard Platen, Sprocket Feed: This printer accepts 8-1/2 inch continuous sprocket feed business forms with a maximum line capacity of 72 characters at 10 characters per inch horizontal spacing.

- Standard Platen, Friction Feed: This printer accepts 8-1/2 inch continuous friction feed teletypewriter roll paper with a maximum line capacity of 72 characters at 10 characters per inch horizontal spacing.

Either printer is capable of handling a maximum of two copies (one original plus two tissues including the necessary interleaved carbons or carbon backed sheets).

SIGNAL CODE

2.08 The code used is the 1968 version of ASCII (American National Standard Code for Information Interchange — X3.4-1968). A code chart is given in Figure 2.

2.09 The 38 typing unit responds to an ASCII configuration in the form of an 8-level, 11-unit code. The code consists of one unit start bit, seven intelligence bits, one parity bit (eighth level), and two stop bits. Figure 3 illustrates the 8-level, 11-unit code for the character "M."

| Bits | | | | | 0 0 0 | 0 0 1 | 0 1 0 | 0 1 1 | 1 0 0 | 1 0 1 | 1 1 0 | 1 1 1 | | | | |
|------|----|----|----|----|-------|-------|--------|-------|-------|-------|-------|-------|---|---|---|-----|
| b7 | b6 | b5 | b4 | b3 | b2 | b1 | COLUMN | ROW | 0 | 1 | 2 | 3 | 4 | 5 | 6 | 7 |
| 0 | 0 | 0 | 0 | 0 | 0 | 0 | 0 | 0 | NUL | DLE | SP | 0 | @ | P | ' | p |
| 0 | 0 | 0 | 1 | 1 | 1 | 1 | 1 | 1 | SOH | DC1 | ! | 1 | A | Q | a | q |
| 0 | 0 | 1 | 0 | 1 | 1 | 0 | 2 | 2 | STX | DC2 | " | 2 | B | R | b | r |
| 0 | 0 | 1 | 1 | 1 | 1 | 1 | 3 | 3 | ETX | DC3 | # | 3 | C | S | c | s |
| 0 | 1 | 0 | 0 | 0 | 0 | 0 | 4 | 4 | EOT | DC4 | \$ | 4 | D | T | d | t |
| 0 | 1 | 0 | 1 | 1 | 1 | 0 | 5 | 5 | ENQ | NAK | % | 5 | E | U | e | u |
| 0 | 1 | 1 | 0 | 1 | 1 | 0 | 6 | 6 | ACK | SYN | & | 6 | F | V | f | v |
| 0 | 1 | 1 | 1 | 1 | 1 | 1 | 7 | 7 | BEL | ETB | ' | 7 | G | W | g | w |
| 1 | 0 | 0 | 0 | 0 | 0 | 0 | 8 | 8 | BS | CAN | (| 8 | H | X | h | x |
| 1 | 0 | 0 | 1 | 1 | 1 | 0 | 9 | 9 | HT | EM |) | 9 | I | Y | i | y |
| 1 | 0 | 1 | 0 | 1 | 1 | 0 | 10 | 10 | LF | SUB | * | : | J | Z | j | z |
| 1 | 0 | 1 | 1 | 1 | 1 | 1 | 11 | 11 | VT | ESC | + | ; | K | [| k | { |
| 1 | 1 | 0 | 0 | 0 | 0 | 0 | 12 | 12 | FF | FS | , | < | L | \ | l | ! |
| 1 | 1 | 0 | 1 | 1 | 1 | 0 | 13 | 13 | CR | GS | - | = | M |] | m | } |
| 1 | 1 | 1 | 0 | 1 | 1 | 0 | 14 | 14 | SO | RS | . | > | N | ^ | n | ~ |
| 1 | 1 | 1 | 1 | 1 | 1 | 1 | 15 | 15 | SI | US | / | ? | O | _ | o | DEL |

Figure 2 - ASCII (X3.4-1968)

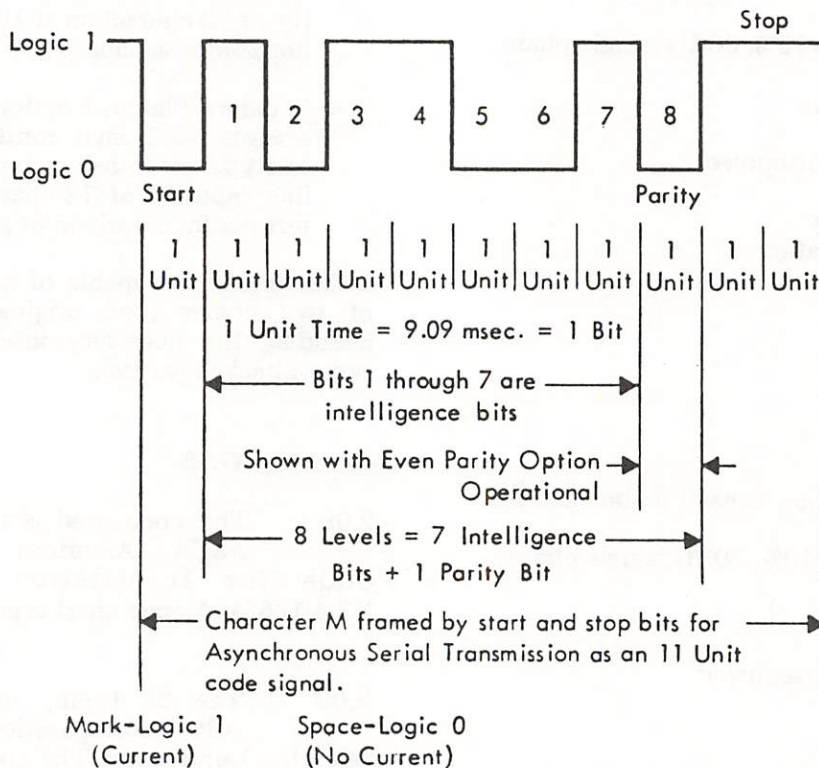

Figure 3 - 8-Level, 11-Unit Code for Character "M"

2.10 The signaling code is a start-stop code of current and no current intervals. Intervals during which the selector magnet is energized are known as marking pulses, and those during which the magnet is not energized are known as spacing pulses. Each group of selecting intervals is preceded by a start interval (no current), and is followed by a stop pulse (current). Both the start and stop pulses are used to maintain synchronism between the transmitting and receiving apparatus.

3. DESCRIPTION

DISTRIBUTOR

3.01 The distributor mechanism is located on the right side of the typing unit toward the rear (Figure 4). The distributor is a disc type with a multiwire input from the keyboard and answer-back mechanisms.

3.02 The code selection set-up in the keyboard contacts (parallel) are distributed sequentially (serial) by a rotating brush. The normal stop position of the brush is near the end of the stop segment to maintain continuous line current in the idle condition.

3.03 Like the keyboard contacts, the contacts in the answer-back mechanism produce a parallel output. The distributor also converts this output and distributes the signal in serial.

ANSWER-BACK MECHANISM

3.04 The answer-back mechanism is located at the rear of the typing unit toward the right side (Figure 5). The function of the answer-back unit is to generate a precoded message, usually a station identification sequence of 20 characters or less. Each character can include up to eight levels of binary information, and can accommodate applications using 5-, 6-, or 8-level codes.

3.05 The answer-back unit is provided with a code drum for encoding the desired character sequence. Complete instructions for encoding the drum are contained in Section 574-422-700TC.

3.06 The code drum has tines which can be easily removed for establishing marking bits in required code level positions. Depending upon the length of an answer-back message, the

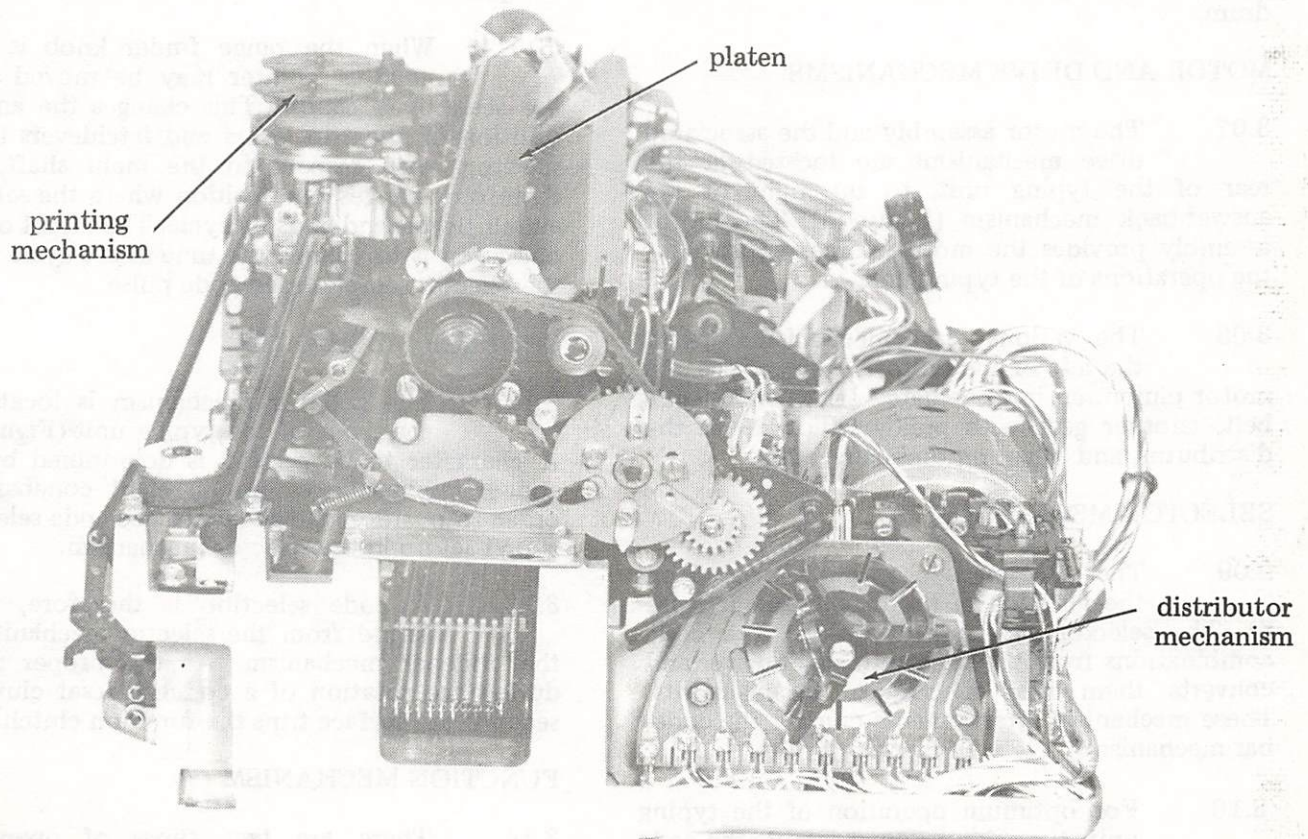

right side view

Figure 4 - Distributor Mechanism

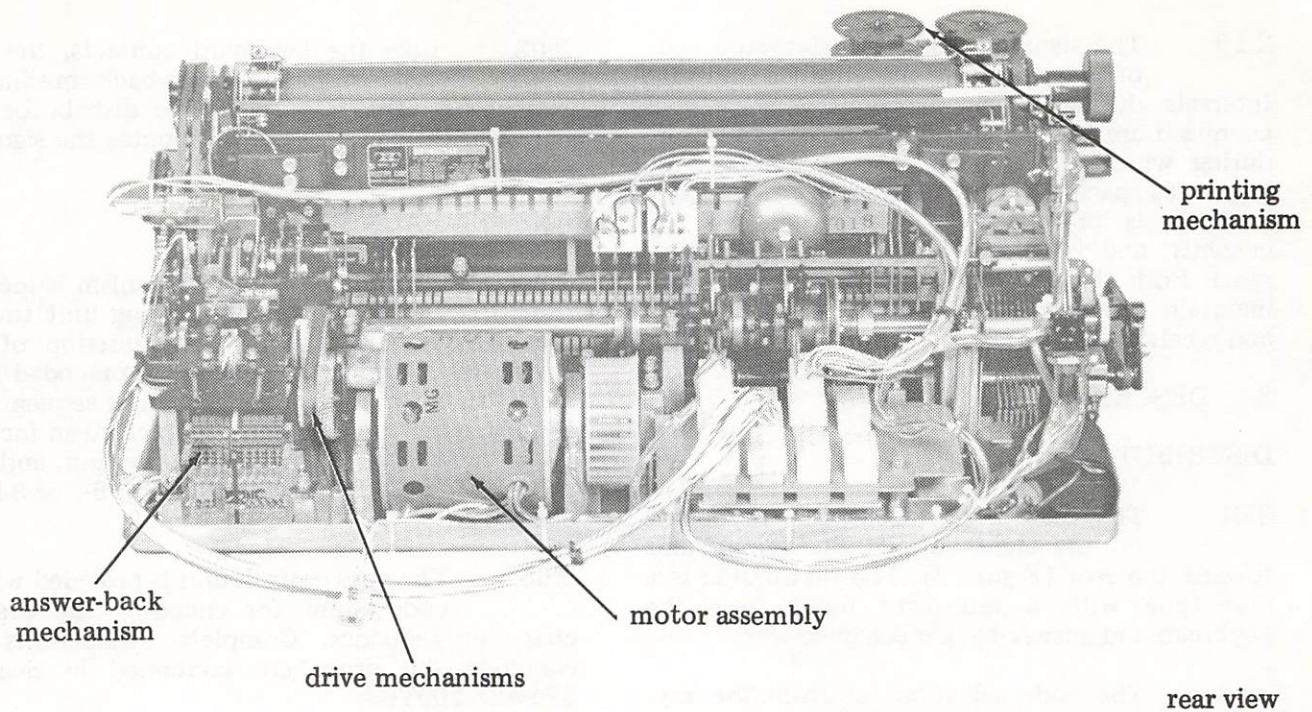

Figure 5 - Answer-Back, Motor, and Drive Mechanisms

answer-back unit can generate one, two, or three identical messages per revolution of the code drum.

MOTOR AND DRIVE MECHANISMS

3.07 The motor assembly and the associated drive mechanisms are located at the rear of the typing unit, to the right of the answer-back mechanism (Figure 5). The motor assembly provides the motive force required for the operations of the typing unit.

3.08 The various drive mechanisms are to the left of the motor. They consist of a motor pinion, an intermediate gear with pulley, a belt, another gear with pulley which drives the distributor, and a gear on the main shaft.

SELECTOR MECHANISM

3.09 The selector mechanism is located on the left side of the typing unit (Figure 6). The selector mechanism receives the code combinations from the selector magnet driver and converts them into mechanical arrangements. These mechanical arrangements control the codebar mechanism.

3.10 For optimum operation of the typing unit, the selector must sample the code elements at the most favorable time. The range finder (Figure 6) provides a means of determining

this time by establishing a range of operating margins.

3.11 When the range finder knob is loosened, a pointer may be moved along the scale by a handle. This changes the angular position of the trip levers and latchlevers in the selector, with respect to the main shaft, and therefore changes the position where the selector clutch begins and ends its cycle. The effect of this operation is to change the time in the cycle when the selector samples each code pulse.

CODEBAR MECHANISM

3.12 The codebar mechanism is located in the front of the typing unit (Figure 7). A character to be printed is determined by the code combination set-up on eight codebars. In order to position the codebars, the code selection is first set up in the selector mechanism.

3.13 A code selection is therefore, transferred from the selector mechanism to the codebar mechanism. At the proper point, during the rotation of a codebar reset clutch, a second cam surface trips the function clutch.

FUNCTION MECHANISM

3.14 There are two types of operations performed by the typing unit. The first includes those mechanical actions which are

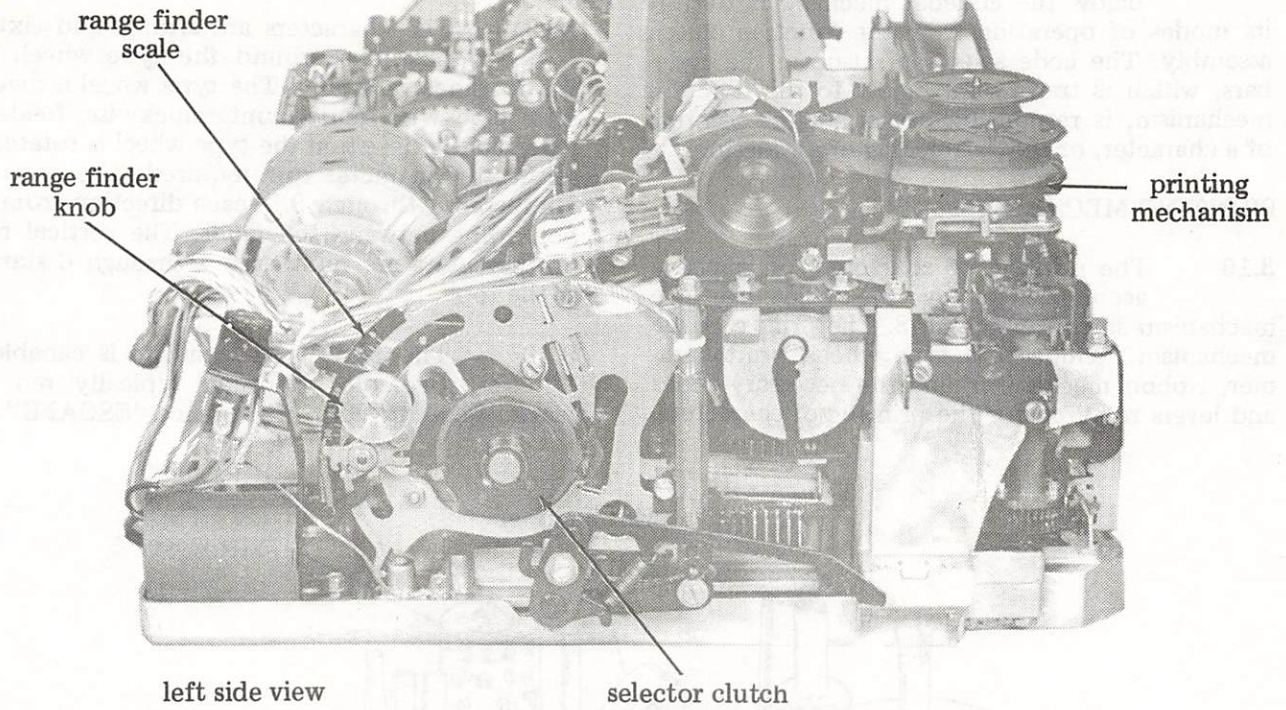

Figure 6 - Selector Mechanism

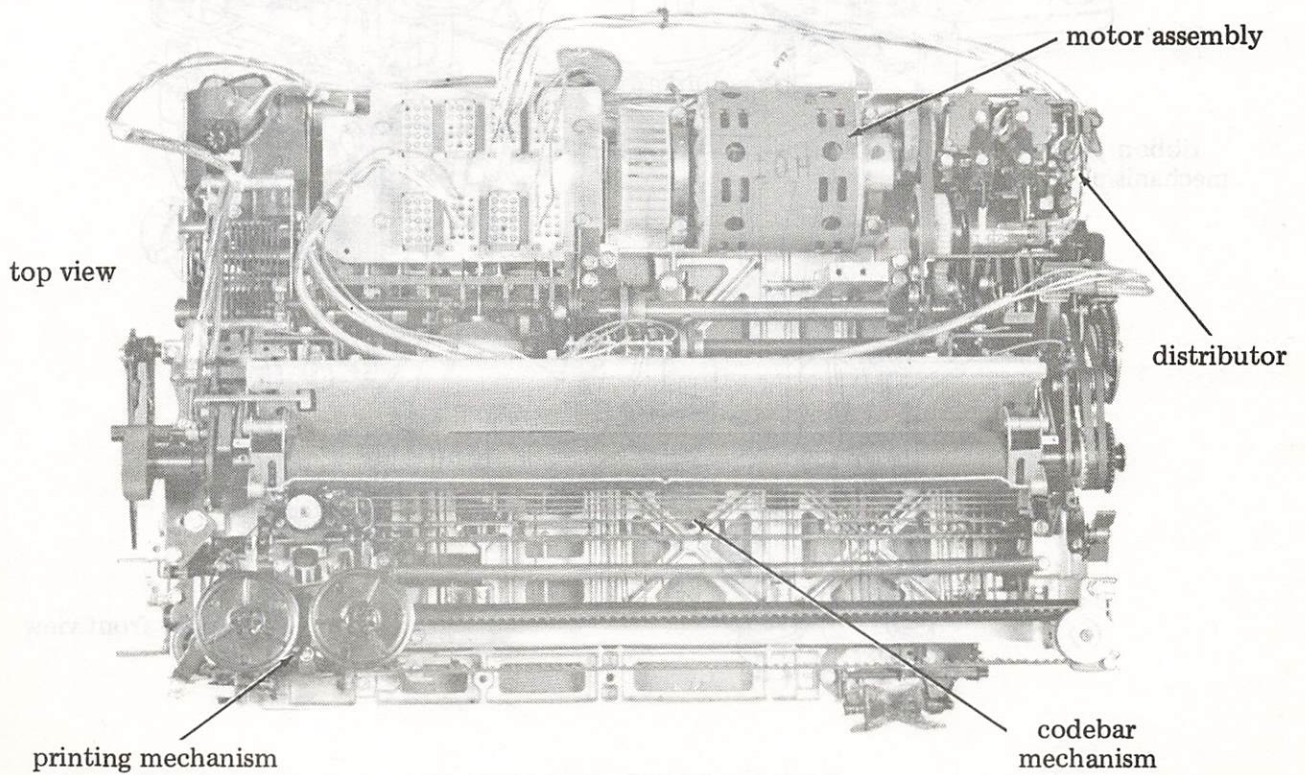

Figure 7 - Codebar Mechanism

necessary to the printing of a character. The second includes those mechanical actions which alter the positions of various mechanisms, but do not print a character.

3.15 The function mechanism, located below the codebar mechanism, derives its modes of operation from the function clutch assembly. The code selection set-up in the codebars, which is transferred below to the function mechanism, is responsible for either the printing of a character, or the performing of a function.

PRINTING MECHANISM

3.16 The printing of characters on paper is accomplished by the print carriage mechanism shown in Figure 8. The print carriage mechanism includes the type wheel, print hammer, ribbon mechanism, and the necessary slides and levers required for the printing of characters.

3.17 The type wheel contains the characters used in printing. The characters are embossed on the surface of the cylindrical type wheel. A typical type wheel character arrangement is given in Figure 9, and shows the characters as they would appear printed.

3.18 The characters are arranged in sixteen positions around the type wheel, and six positions vertically. The type wheel is divided into clockwise and counterclockwise fields to indicate the direction the type wheel is rotated to select the character row required. The rows are numbered 1 through 8 in each direction from the borderline between the fields. The vertical rows of characters are numbered 1 through 6 starting at the top.

3.19 The printing mechanism is capable of two-color printing, typically red and black. When the control sequence "ESCAPE" "3"

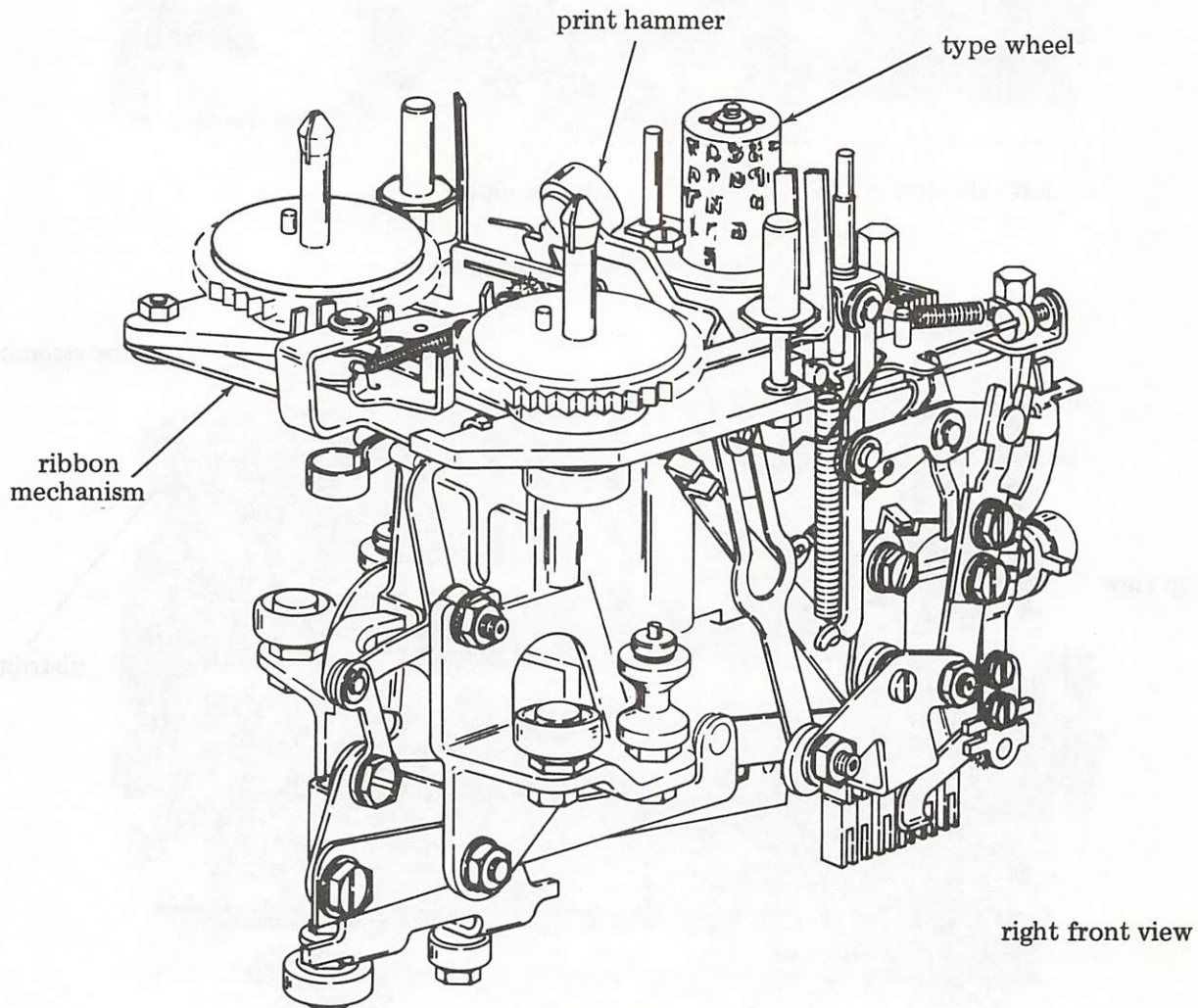

Figure 8 - Print Carriage Mechanism

| | clockwise | | | | | | | | counterclockwise | | | | | | | |
|---|-----------|---|-----|-----|---|---|---|--------|------------------|---|--------------|-------------|--------------|------------|---|--------|
| | 8 | 7 | 6 | 5 | 4 | 3 | 2 | 1 | 1 | 2 | 3 | 4 | 5 | 6 | 7 | 8 |
| 1 | ' | & | % | \$ | # | " | ! | A D | (|) | * | + | , | - | . | / |
| | BELL | | WRU | EOT | | | | SPACE | BACK SPACE | | LINE FEED | VERT TAB | FORM FEED | CAR RET | | |
| 2 | 7 | 6 | 5 | 4 | 3 | 2 | 1 | 0 | 8 | 9 | : | ; | < | = | > | ? |
| 3 | G | F | E | D | C | B | A | @ | H | I | J | K | L | M | N | O |
| 4 | W | V | U | T | S | R | Q | P | X | Y | Z | [| \ |] | ^ | _ |
| 5 | g | f | e | d | c | b | a | ' | h | i | j | k | l | m | n | o |
| 6 | w | v | u | t | s | r | q | p | x | y | z | { | | } | ~ | DELETE |

NOTE 1: Shaded areas are nonprinting functions. However, the type wheel is positioned in the character area for the function shown.

NOTE 2: The type wheel arrangement ("AD" for example) is embossed in the area where the type wheel is positioned during the nonprinting function "SPACE." The arrangement (AD) does not print.

Figure 9 - Typical Type Wheel Character Arrangement (as Printed)

is received, the printing mechanism is conditioned to print all succeeding characters in red. When the control sequence "ESCAPE" "4" is received, the printing mechanism drops the red printing mode, and all succeeding characters are printed in black. During the control sequences (shifting from red to black, and black to red printing), printing and spacing is suppressed.

4. PRINCIPLES OF OPERATION

DISTRIBUTOR

A. General

4.01 The distributor mechanism, located on the right side of the typing unit, receives a code signal locally. The signal originates from an associated keyboard or a tape reader.

4.02 The distributor changes the parallel signal into a serial start-stop output to the selector magnet driver for current rectification. The signal goes from the selector magnet driver to the selector. The following discussion considers the signal originating locally from an associated keyboard.

B. Operation

4.03 The distributor mechanism is illustrated in Figures 10 and 11. When a keytop is depressed, the corresponding code combination is set up in the keyboard contacts. Simultaneously the universal lever moves up. An H-plate connects the universal lever of the keyboard to the distributor clutch trip linkage in the typing unit. As the universal lever moves up, the H-plate pivots the distributor trip linkage. The distributor

trip linkage is connected to the clutch trip lever. As the linkage moves rearward the trip lever is moved away from the shoe lever and the distributor clutch engages.

4.04 The clutch disc is attached to the distributor shaft. A brush holder mounted at the end of the distributor shaft rotates two carbon brushes over the segments of the distributor disc. A spring fastened to the brush holder serves two purposes: it holds the carbon brushes firmly against the segments, and serves to close the current loop between the outer and inner rings of the distributor disc.

4.05 The distributor disc has two rings. The inner ring is solid. The outer ring is broken into ten segments corresponding to the start, stop, and the eight intelligence pulses.

(a) In the stop position, the outer brush rests on the stop segment, and the current flows in the signal circuit which is

closed. (The signal path is from one side of the line through the start segment, the inner ring, the brushes, the stop segment, the common terminal, and the break contact to the other side of the line.) Thus a marking condition exists. Assume that the D key is depressed. The (--3--7-) code combination is set up in the keyboard contacts.

(b) The distributor clutch is tripped, and the brush holder begins its revolution. While the brush is on the start segment, the circuit is open, no current flows, and a spacing element is transmitted. While it is on the no. 1 segment, the circuit is again open. Likewise the circuit is open for the no. 2 pulse. On the no. 3 segment the circuit is closed, current flows and a marking element is transmitted. For the nos. 4, 5, and 6 segments the circuit is open, transmitting spacing elements. The circuit closes for the no. 7 element and opens for the no. 8. When

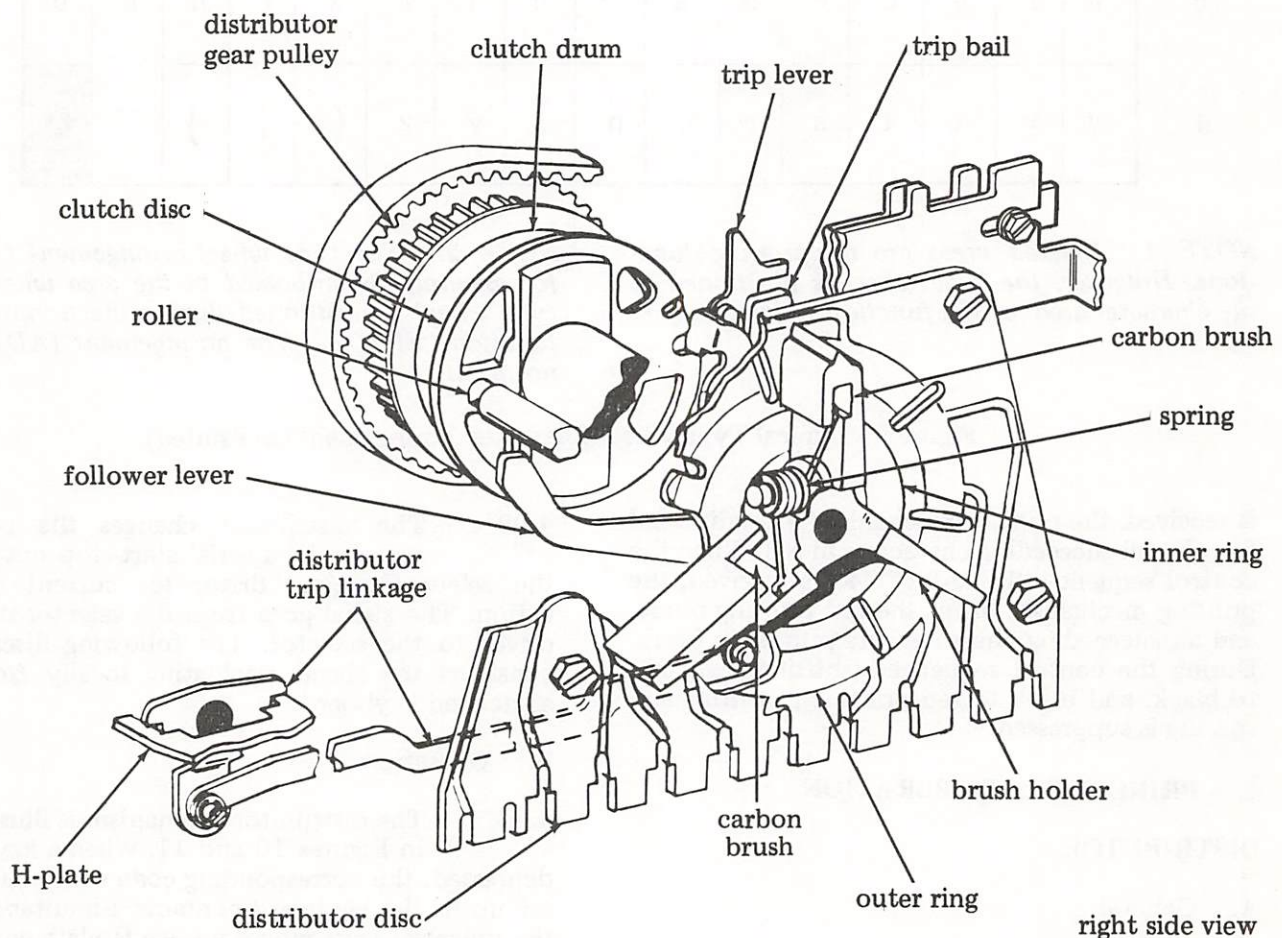

Figure 10 - Distributor Mechanism

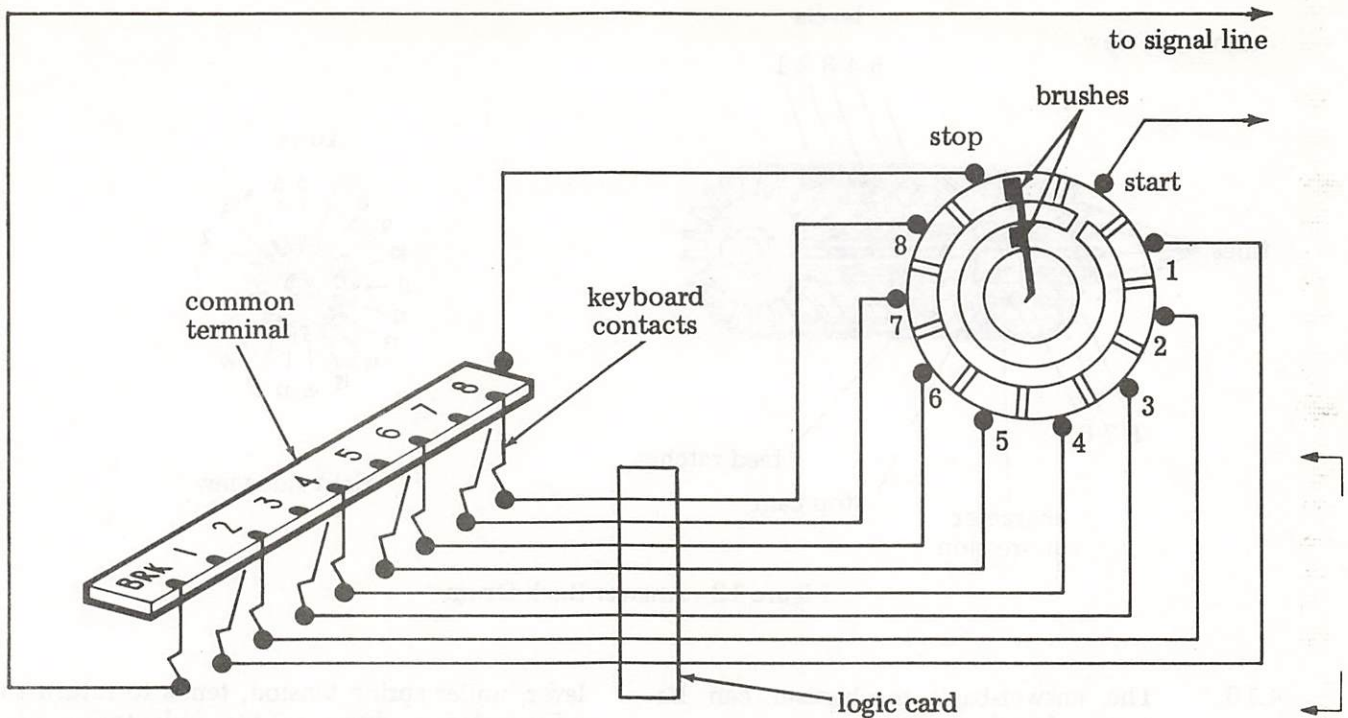

Figure 11 - Signal Wiring for 38 Typing Unit Distributor

the brush reaches the stop segment, the distributor clutch is disengaged, and the line again becomes marking.

ANSWER-BACK MECHANISM

4.06 The answer-back mechanism illustrated in Figures 12 through 15 automatically transmits a predetermined sequence of characters for identification purposes.

A. Answer-Back Drum

4.07 A drum is coded with characters making up the answer-back sequence. When the answer-back mechanism is actuated, it rotates the drum, which sets up the code combinations in a set of answer-back contacts. The distributor converts the positions of the contacts to start-stop signals for transmission. After the answer-back sequence has been transmitted, the answer-back mechanism returns itself to its unoperated condition. For reasons that will be described, provisions are made for shunting the signal line during sensing of the first answer-back character of each cycle; and to prevent the answer-back from being actuated by the local generation of the answer-back call character.

4.08 The answer-back drum illustrated in Figure 12 has 11 levels as follows:

- (a) Five numbered levels

- (b) Feed ratchet
- (c) Stop cam
- (d) Character suppression
- (e) Three more numbered levels

4.09 Viewing it from the numbered end, the answer-back drum has 21 rows, ST (start) and 1 through 20. The feed ratchet serves to rotate the drum. The stop cam has tines which can be removed at various points so that the length of the answer-back message can be varied. The character suppression level is used to shunt the first answer-back character from the signal line. By breaking off tines in the various rows at the numbered intelligence levels, the drum may be coded to generate the proper answer-back characters. For example, if the first character of an answer-back message to be transmitted is the letter D code combination (--3--7-), tines at the no. 3 and no. 7 levels should be broken off in the appropriate row where the answer-back message is to start. The second character of the message would be coded into the next succeeding row.

NOTE 1: All answer-back messages should be preceded by the "carriage return" and "line feed" code combinations.

NOTE 2: For details on answer-back drum coding refer to Section 574-422-700TC.

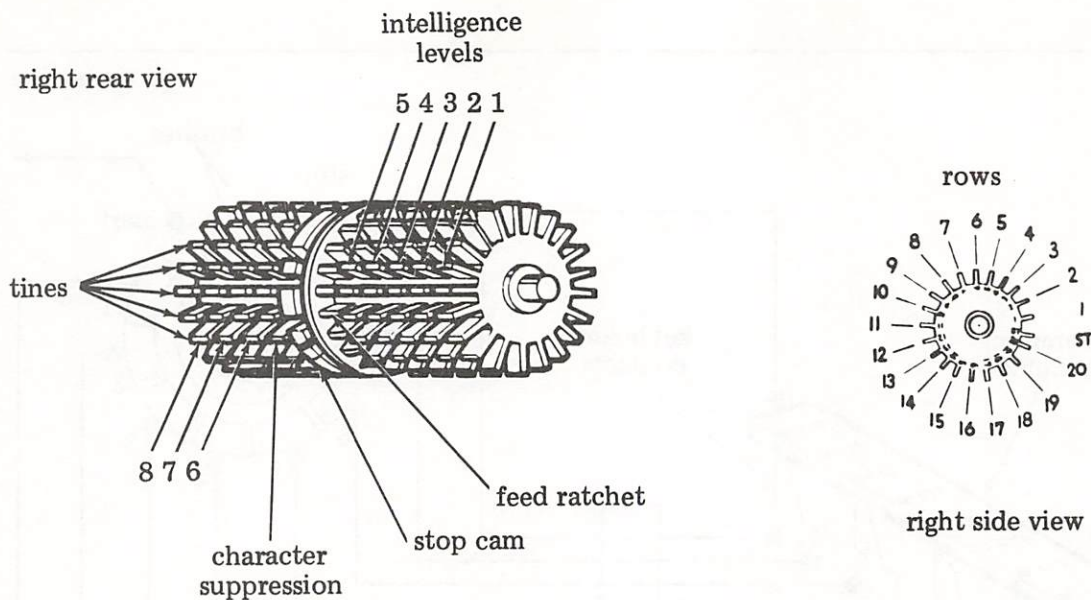

Figure 12 - Answer-Back Drum

4.10 The answer-back mechanism can be actuated in three ways.

- (a) Remotely, by the reception of a pre-determined call character.
- (b) Locally, by depressing the HERE IS key.
- (c) Automatically, by actuating the answer-back trip magnet mechanism from some external equipment, such as a data set.

B. Remote Actuation (Figure 13)

4.11 When the answer-back call character is received by the typing unit, the answer-back function lever moves up to engage its function pawl. As the function lever and pawl are moved down by the function bail, the pawl pivots the answer-back bail. In pivoting, the answer-back bail moves a trip link forward. The trip link pivots the control lever out of the indentation on the stop cam. The control lever, through the stop bail, moves the trip lever rearward, out of engagement with the shoe lever, allowing the distributor clutch to engage.

4.12 When the distributor clutch begins to rotate, a cam roller moves up and permits the feed lever to pivot rearward against the control lever. The feed pawl attached to the feed lever moves rearward to engage the next tooth on the drum ratchet. Near the end of the function cycle the function pawl is stripped from its function lever by the stripper bail. The control

lever, under spring tension, tends to return to its unoperated position in the indentation of the stop cam. This would terminate the answer-back operation by disengaging the distributor clutch. However, since the feed pawl is engaged with the next tooth on the ratchet, the spring tension on the control lever is not enough to overcome the combined tension of the feed lever spring and the drum detent. Thus the mechanism remains in its operated condition throughout the distributor cycle.

4.13 Near the end of the distributor cycle, the cam roller on the distributor clutch moves the feed lever and feed pawl forward, and the pawl acts on the ratchet to rotate the drum one tooth. The stop cam on the drum now prevents the control lever and trip lever from returning to their stop position. The distributor clutch thus continues to cycle and rotates the answer-back drum.

4.14 The answer-back contacts are wired in parallel with the keyboard contacts to the segments of the distributor disc. As the drum rotates during the answer-back operation, the contact wires, under spring tension, sense each row of tines. If a tine has been broken off at a given level in a row, the associated wire moves forward to its marking position against a common terminal. On the other hand, if a tine is present, it holds the wire away from the terminal in its spacing position. As the distributor clutch cycles, the distributor converts the positions of the contacts to sequential start-stop signals for transmission.

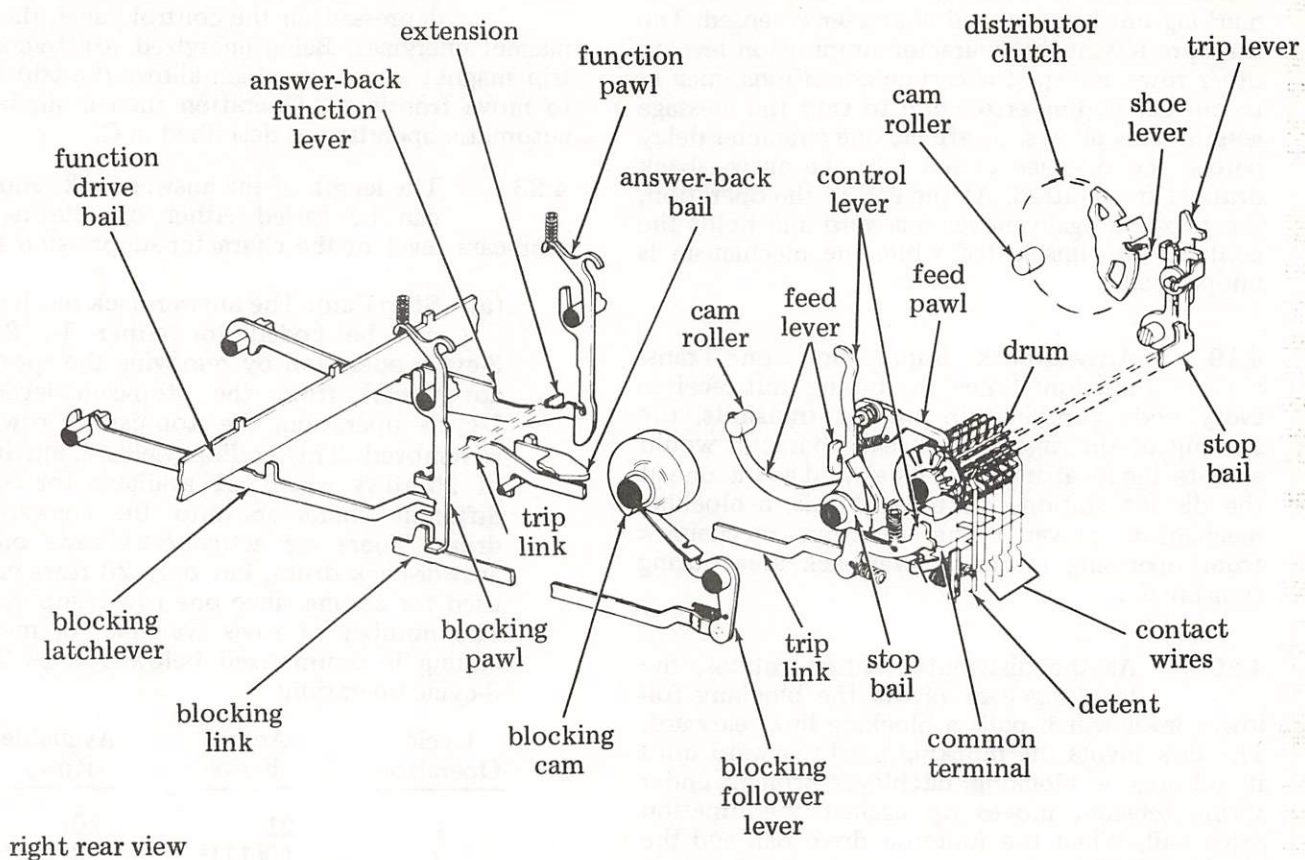

Figure 13 - Answer-Back Mechanism Remote Actuation

4.15 The drum continues to rotate until the next indentation in the stop cam is presented to the control lever. The latter then moves into the indentation and returns the associated parts to their unoperated position. The shoe lever then strikes the trip lever and disengages the distributor clutch. The mechanism is thus returned to its unoperated condition.

C. Automatic Actuation (Figure 14)

4.16 The answer-back mechanism of a distant station may be actuated by completing a connection through the local data set or some other equipment. The trip magnet on the distant station is energized. Being energized it attracts the trip magnet armature which allows the trip lever to move forward. A tab on the trip lever pivots the control lever out of the indent of the stop cam allowing the clutch to engage. As the clutch rotates the blocking cam also rotates. A blocking follower rides the blocking cam and rotates clockwise. By means of a tab the blocking follower rotates the trip lever which latches against the de-energized armature extension. It remains in this position until the magnet is again energized.

4.17 Since the answer-back, keyboard, and tape reader (where used) contacts are wired in parallel with the distributor disc, the answer-back contacts must all be in their spacing position when the mechanism is unoperated, so that they do not interfere with keyboard or tape reader transmission. Therefore, because the answer-back feed mechanism does not feed the drum until near the end of the first cycle, the first character sensed should be all spacing to prevent garbling of the regular message sent from the keyboard and/or tape reader. However, an all "spacing" character is undesirable in some systems. Therefore, a way is provided for shunting transmission from the signal line during the sensing of the first answer-back character.

4.18 As mentioned, the trip link moves forward when the answer-back sequence is initiated and remains there until it is terminated. In this position it permits a character suppression contact wire to sense the drum character suppression level. The character suppression contact is wired so that it shunts transmission from the outgoing signal line when it is closed. The time at the character suppression level of the first character of each answer-back

cycle must always be broken off in order to accomplish this. Thus the character suppression contact wire is selected and keeps the line marking until the second character is sensed. The tines are left in the character suppression level in other rows, except for certain conditions, such as to correct coding errors and to vary the message length. This allows, in effect, one character delay before the message coded into the answer-back drum is transmitted. At the end of the operation, the trip link again moves rearward and holds the contact wire unselected while the mechanism is unoperated.

4.19 Answer-back Suppression on Transmission: Since the typing unit receives every code combination that it transmits, the sending of the answer-back call character would actuate the local answer-back as well as the one at the distant station. To prevent this, a blocking mechanism prevents the function mechanism from operating in the answer-back area during transmission.

4.20 As the distributor clutch rotates, the blocking cam pivots the blocking lower lever which pulls a blocking link rearward. The link pivots the blocking pawl rearward until it releases a blocking latchlever which, under spring tension, moves up against the function drive bail. When the function drive bail and the blocking latchlever move up during the function cycle, the blocking latchlever cams the blocking pawl further rearward where an extension on the pawl is over an extension on the answer-back function lever. The function lever is thus prevented from moving up far enough to be latched by its pawl and initiate the answer-back sequence.

4.21 During the latter part of the distributor cycle, the blocking cam allows the blocking link to move frontward to its unoperated position. As the function drive bail moves down during the middle portion of the function cycle, it drives the blocking latchlever downward to the point where the blocking pawl is permitted to pivot frontward to its unoperated position. Thus every time a character is initiated locally, the distributor clutch cycles and operates the blocking mechanism which prevents the answer-back function lever from sensing the codebars and initiating the answer-back sequence regardless of what character is processed by the typing unit. On the other hand, when remotely initiated characters are received, the distributor clutch does not cycle, the blocking mechanism is not operated, and the function lever is permitted to sense the codebars and initiate the answer-back sequence upon receipt of the predetermined call-character signal.

D. Local Actuation (Refer to Figure 14)

4.22 When the HERE IS pushbutton is depressed on the control panel, the trip magnet energizes. Being energized it attracts the trip magnet armature which allows the trip lever to move frontward. Operation then is similar to automatic operation as described in C.

4.23 The length of the answer-back sequence can be varied either by altering the stop-cam level or the character-suppression level.

(a) Stop Cam: The answer-back mechanism can be coded for either 1-, 2-, or 3-cycle operation by removing the appropriate tine(s) from the stop-cam level. In 1-cycle operation, the stop cam in row "6" is removed. This coding yields a maximum of 20 rows which are available for coding different characters into the answer-back drum. There are actually 21 rows on the answer-back drum, but only 20 rows can be used for coding since one row is suppressed. The number of rows available for message coding is summarized below for 1-, 2-, or 3-cycle operation:

| Cycle Operation | Actual Rows | Available Rows |
|-----------------|-------------|----------------|
| 1 | 21 | 20 |
| 2 | 10(11)* | 9(10)* |
| 3 | 7 | 6 |

*Alternately, one then the other.

When multiple-cycle operation is employed, the answer-back sequence must be coded in each segment of the answer-back drum so that the same message will be transmitted each time the answer-back mechanism is initiated.

(b) Character Suppression: Quite often, due to message length, messages coded into the answer-back drum do not require the use of every available row for coding. Unneeded rows are eliminated from the message transmission by removing the unneeded character suppression tine(s). The answer-back drum will continue through its complete cycle, but the transmission of the coded characters from the unneeded rows will be shunted from the signal line.

NOTE: The character-suppression tine in the last row of a cycle should not be removed on 38 typing units used in systems where a response to each answer-back actuation signal must always be obtained. If the tine is removed, the answer-back mechanism will not respond to consecutive answer-back actuation signals. This is due to the operating characteristics of the typing unit which, when the character-suppression tine in the last

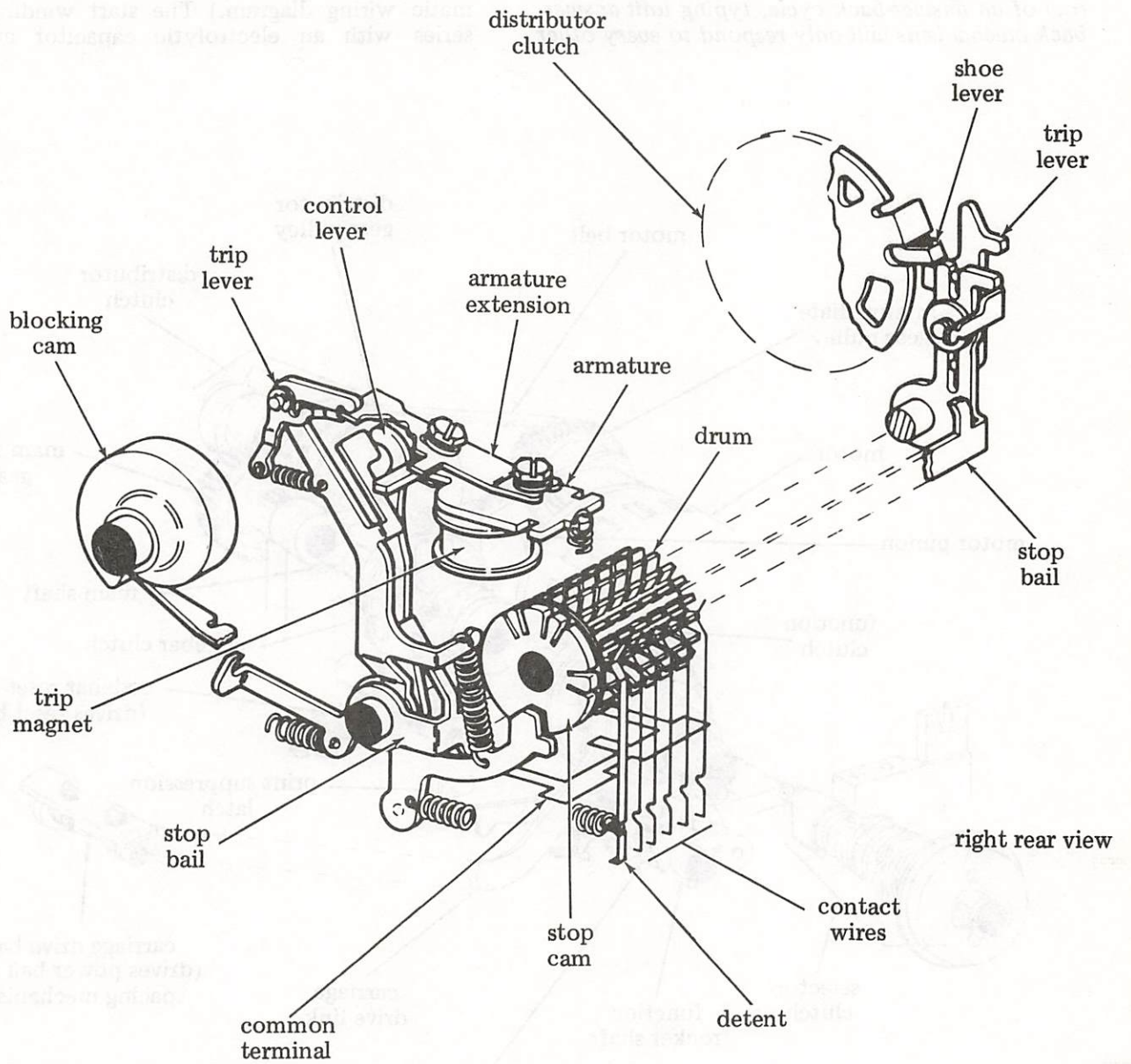

Figure 14 - Answer-Back Mechanism Automatic Actuation

row of a cycle is removed, leaves the answer-back blocking pawl blocking at the end of the answer-back drum cycle of operation. The answer-back blocking pawl will remain blocking until after another character is received through the selector mechanism. The subsequently received character causes the function mechanism to reset the answer-back blocking pawl to its unblocking position. After being reset and upon receipt of an answer-back actuation signal, the answer-back mechanism will be triggered. Hence, with the character-suppression time removed from the last row of an answer-back cycle, typing unit answer-back mechanisms will only respond to every other

answer-back actuation signal unless an intervening character is received through the selector mechanism.

MOTOR AND DRIVE MECHANISMS

A. Motor and Intermediate Gearing (Figure 15)

4.24 The motor used on the 38 typing unit has a run winding and a start winding connected in parallel. (See the appropriate schematic wiring diagram.) The start winding is in series with an electrolytic capacitor and the

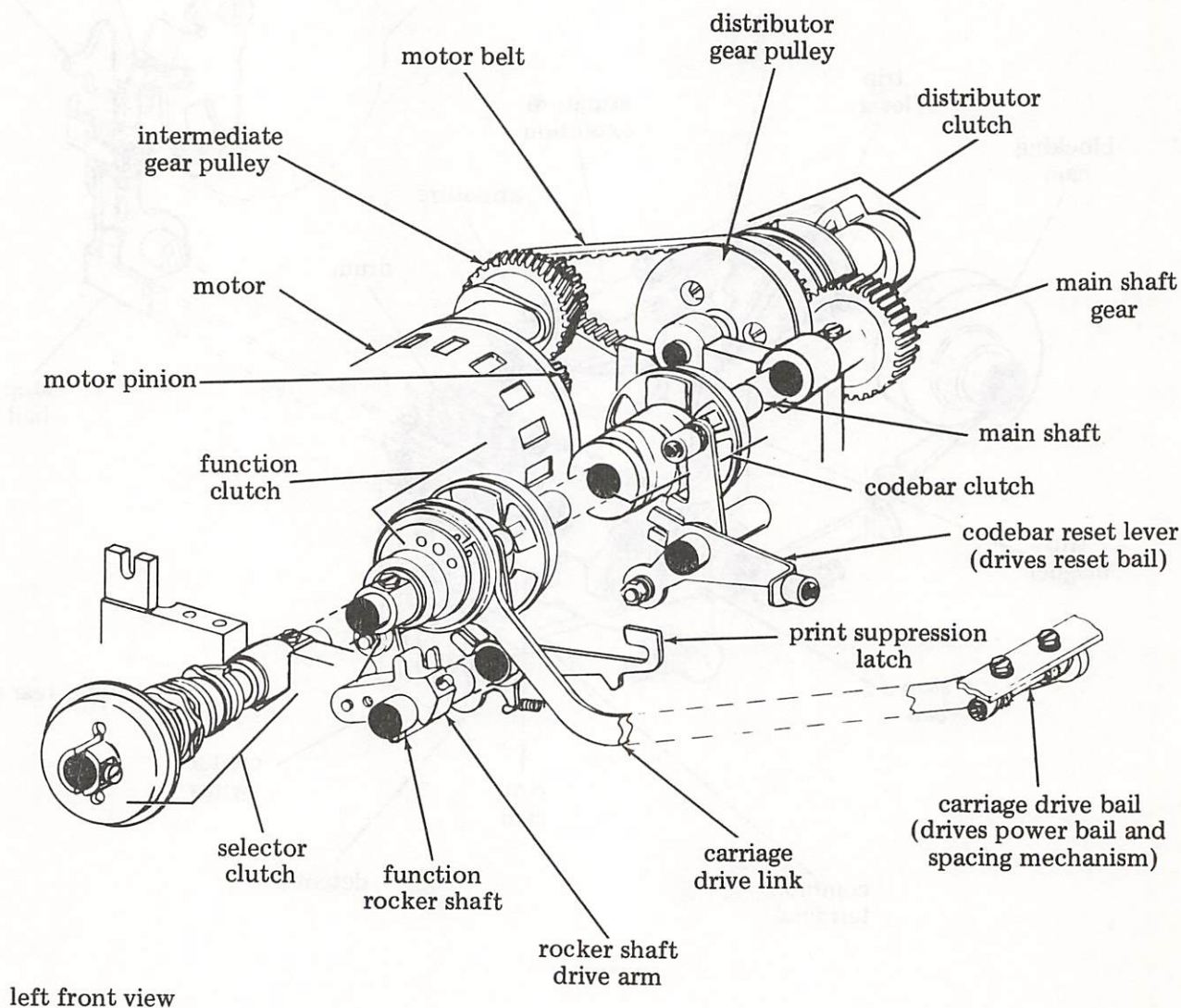

Figure 15 - Motor and Drive Mechanisms

contacts of a current-sensitive start relay. The run winding is connected to a run capacitor. When the motor circuit is closed, the initial surge of current energizes the relay coil, closing the relay contacts. The magnetic flux produced by the operating and start windings starts the motor turning. As the rotor accelerates, the current, through the windings, capacitor, and relay decreases. When it drops to a predetermined level, the relay coil opens the contacts and removes the start coil from the circuit. Using the operating coil alone, the motor continues to accelerate until it reaches synchronous speed.

4.25 The rotary motion produced by the motor is transferred through a motor pinion, an intermediate gear pulley, and a motor belt to a distributor gear pulley. The latter drives a main shaft gear and also a distributor clutch, which provides motion for the keyboard and distributor mechanism.

B. Main Shaft

4.26 The main shaft illustrated in Figure 16 receives motion from the motor, and by means of clutches, distributes it to drive all the mechanisms in the typing unit except the distributor mechanism. The distributor mechanism is driven by the motor directly as explained in 4.25.

In friction feed typing units, the main shaft drives three clutches: the selector clutch, the function clutch, and the codebar clutch. In sprocket feed typing units the main shaft drives an additional clutch — the form feed clutch.

C. Clutches

4.27 The clutches used on the 38 typing unit are all metal internal expansion clutches. A clutch is illustrated in Figure 17. This type of clutch functions like brakes. When the clutch is tripped (engaged) two shoes expand against a notched drum. The force of the expanded shoes against the clutch drum is enough to engage the drum. As the drum rotates, the whole clutch and any mechanism attached to it will rotate.

4.28 The clutch drum is attached to and rotates with a shaft. In the stop (or disengaged) position, a trip lever and a latch lever hold the shoe lever, two shoes, a cam disc, and a cam sleeve stationary. When the trip lever moves away from the shoe lever, the shoe lever, under spring tension, moves away from the stop-lug on the cam disc. By means of two lugs, the shoe lever expands the shoes until they contact the notched surface of the drum. The drum causes the shoes to rotate. By means of a lug on the cam disc the

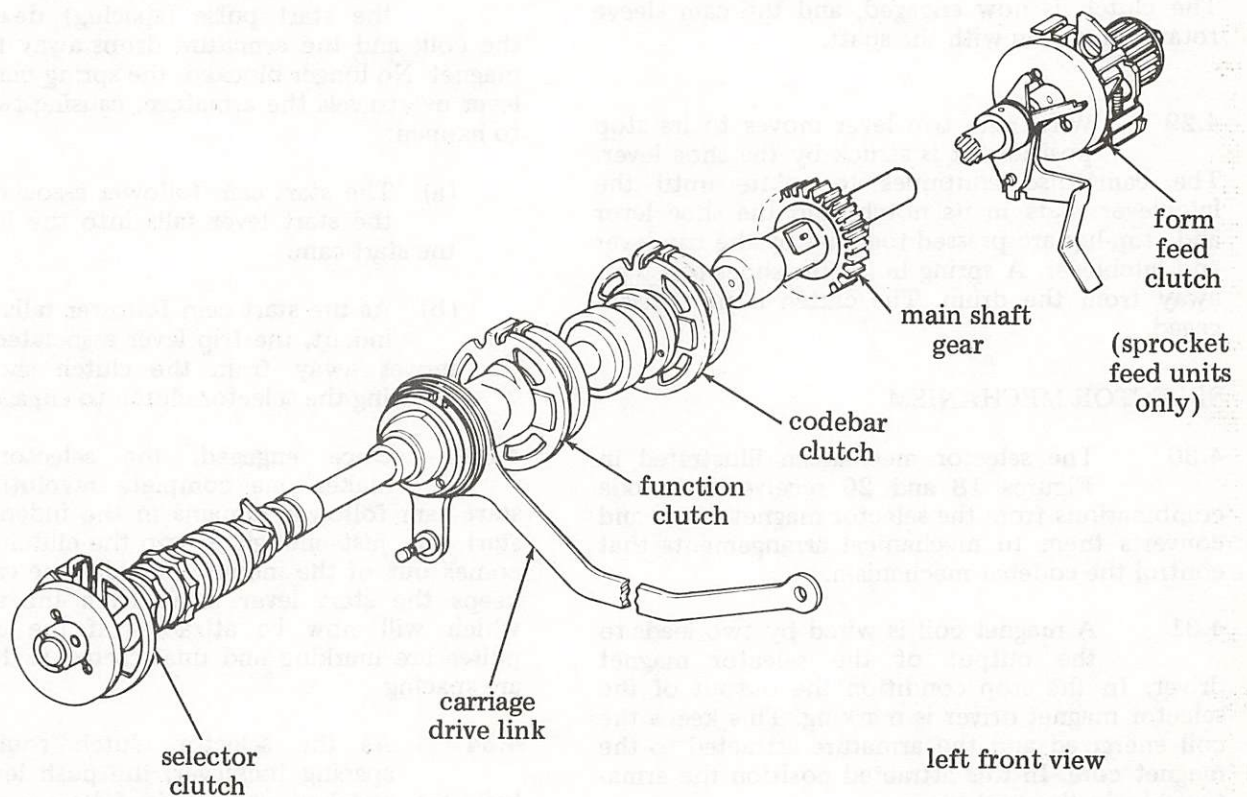

Figure 16 - Main Shaft

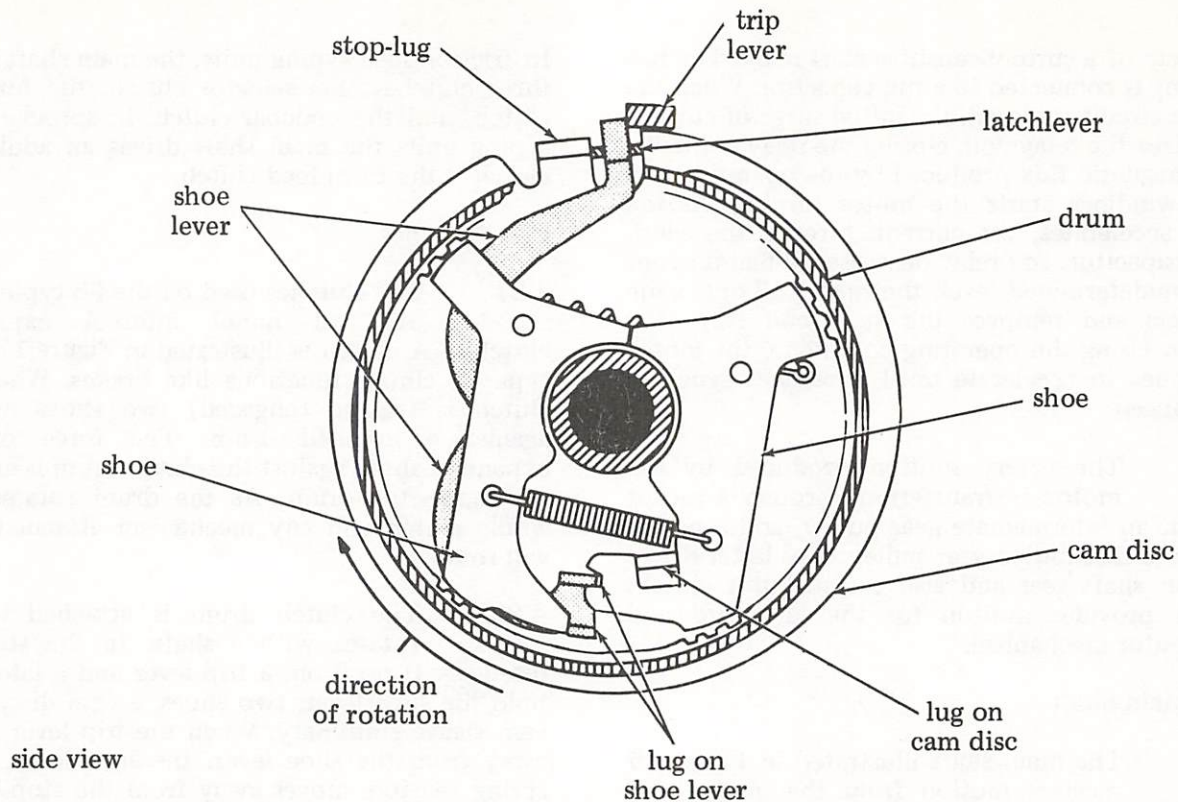

Figure 17 - Internal Expansion Clutch

shoes rotate the disc and the sleeve attached to it. The clutch is now engaged, and the cam sleeve rotates in unison with the shaft.

4.29 When the trip lever moves to its stop position, it is struck by the shoe lever. The cam disc continues to rotate until the latchlever seats in its notch, and the shoe lever and stop-lug are pressed together by the trip lever and latchlever. A spring holds the shoes together, away from the drum. The clutch is now disengaged.

SELECTOR MECHANISM

4.30 The selector mechanism illustrated in Figures 18 and 20 receives the code combinations from the selector magnet driver and converts them to mechanical arrangements that control the codebar mechanism.

4.31 A magnet coil is wired by two leads to the output of the selector magnet driver. In the stop condition the output of the selector magnet driver is marking. This keeps the coil energized and the armature attracted to the magnet core. In this attracted position the armature blocks the start lever.

4.32 When a code combination is received, the start pulse (spacing) de-energizes the coil, and the armature drops away from the magnet. No longer blocked, the spring biased start lever overtravels the armature, causing two things to happen:

- (a) The start cam follower associated with the start lever falls into the indent of the start cam.
- (b) As the start cam follower falls into the indent, the trip lever associated with it moves away from the clutch shoe lever, allowing the selector clutch to engage.

4.33 Once engaged, the selector clutch makes one complete revolution. The start cam follower remains in the indent of the start cam just enough to trip the clutch. It then comes out of the indent and rides the cam. This keeps the start lever away from the armature which will now be attracted if the incoming pulses are marking and unattracted if the pulses are spacing.

4.34 As the selector clutch rotates, the spacing locklever, the push lever reset bail, the codebar clutch trip follower arm, and

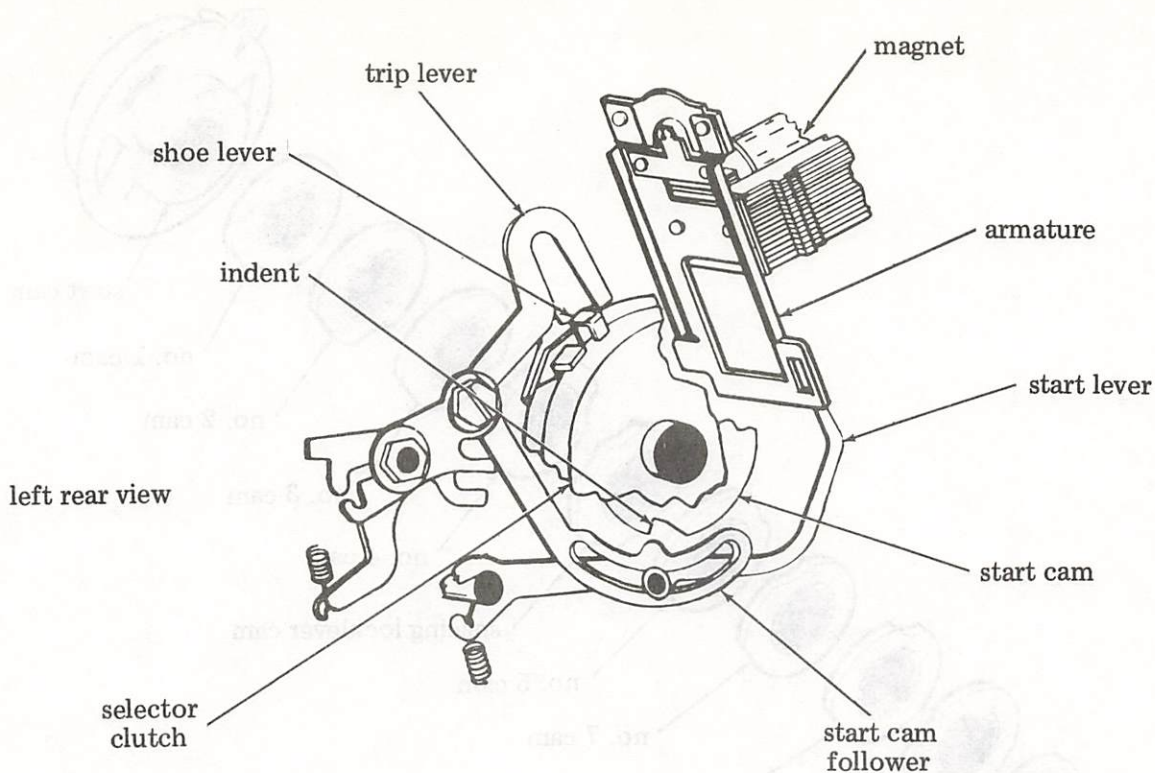

Figure 18 - Selector Trip Mechanism

eight selector levers ride individual cams under spring tension.

4.35 Early in the codebar cycle, the high part of the push lever reset cam pivots the push lever reset bail. In its motion, the bail resets all the spring biased push levers selected in the previous cycle. Once reset, the push levers can be positioned either marking or spacing as the intelligence pulses are received.

4.36 The selector cam sleeve illustrated in Figure 19 has twelve cam surfaces. The cam surfaces are positioned in a staggered fashion so that a sampling sequence can take place. As mentioned in 4.32 and 4.33, the start cam performs its function, and soon after the push lever reset cam is operated. Following these, the spacing locklever cam and the eight intelligence cams operate in sequence.

NOTE: The sampling sequence for the intelligence cams is as follows: no. 1, 2, 3, 4, 5, 6, 7, and 8. However, the physical arrangement of the cams is: 1, 2, 3, 4, 5, 7, 6, and 8 as viewed from left to right.

4.37 If the intelligence pulse is spacing it de-energizes the magnet coil and the armature is in the unattracted position. The spacing locklever moves up, holding the armature

in this position during the sampling interval. The selector lever is prevented from moving up into the indent of its cam by the armature, and the push lever remains in its unselected (spacing) position in front of the selector lever (Figure 20).

4.38 If the intelligence pulse is marking the armature is attracted, moving out of the way of the selector lever, blocking the spacing locklever. The selector lever moves up into the indent of its cam, locking the armature in its marking position during the sampling interval. This permits the spring biased push lever to move rearward under the selector lever.

4.39 As the code combination is received, each intelligence pulse is sampled in turn, and the corresponding selector levers and push levers are positioned accordingly. The contours of the selector cams are such that near the end of the cycle they drive the selector levers and selected push levers down to their marking position. In this position, the blocking levers with their slotted portions are up. The blocking levers associated with the unselected push levers remain in the spacing position in which their slotted portion is down (Figure 20).

4.40 Near the end of the cycle, the trip follower arm is moved rearward by its cam and trips the codebar clutch.

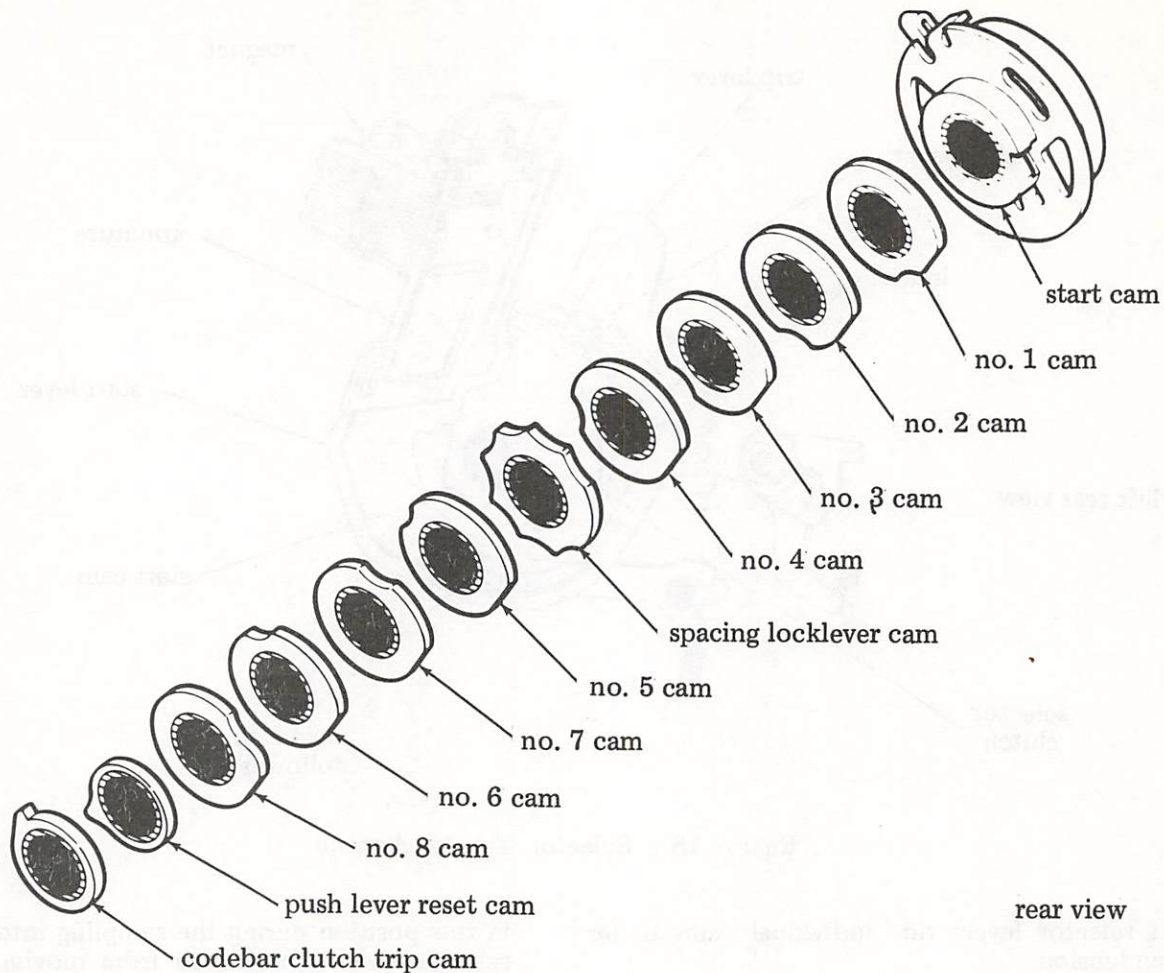

Figure 19 - Selector Cam Sleeve

4.41 When the stop pulse (marking) is received at the end of the code combination, the armature moves to its marking position above the start lever, where it prevents the start cam follower from falling into the indent of its cam. In this position the follower holds the trip lever down so that, when the selector clutch completes its cycle, its shoe lever strikes the trip lever, and the clutch is disengaged.

4.42 As an example, assume that the letter D (--3--7-) code combination is received by the typing unit. The start pulse (spacing) trips the selector clutch, which begins its cycle. The stripper bail strips all previously selected push levers from the selector levers. The intelligence pulses are sampled in order, and the no. 3 and no. 7 push levers are selected. Near the end of the cycle the selector clutch cams the no. 3 and no. 7 push levers down, and they pivot the no. 3 and no. 7 blocking levers up to their marking position. The trip cam causes the trip follower arm to trip the codebar clutch. The stop pulse (marking)

disengages the selector clutch, and the selector returns to its stop position.

RANGE FINDER

4.43 For optimum operation of the typing unit, the selector must sample the code elements at the most favorable time. The range finder illustrated in Figure 21 provides a means of determining this time by establishing a range of operating margins.

4.44 When the range finder knob is loosened, a pointer may be moved along a range scale by a handle. This changes the angular position of the trip levers and latchlevers with respect to the main shaft, and thus changes the position where the selector clutch begins and ends its cycle. The effect of this operation is to change the time in the cycle when the selector samples each code pulse.

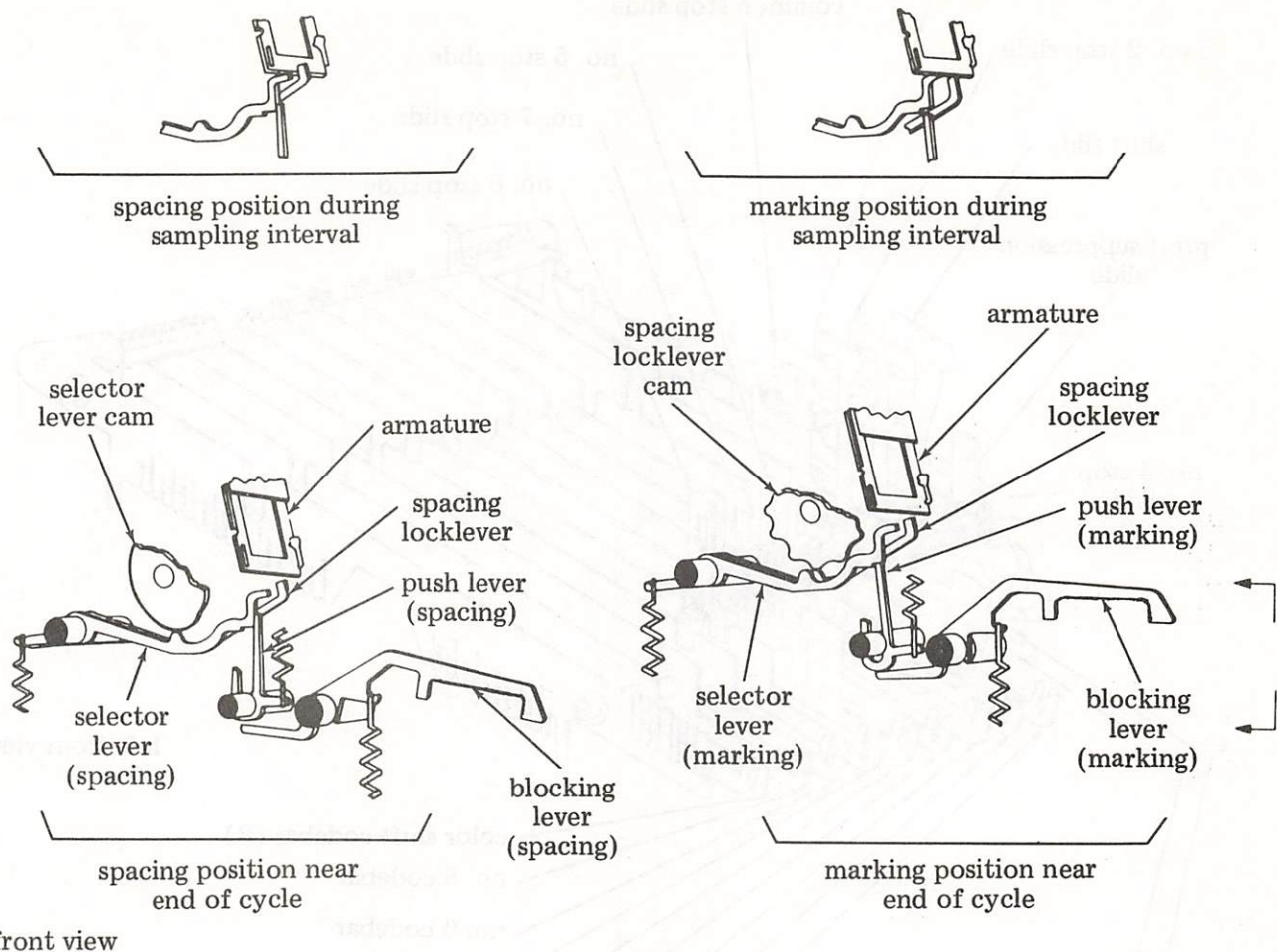

Figure 20 - Selector Mechanism

4.45 Rotating the pointer counterclockwise from 60, the center of the scale, causes the selector to sample the trailing portion of the pulse. Rotating the pointer clockwise causes the selector to sample the leading edge. To establish the margins of the operating range, the pointer is moved first in one direction, then in the other, until errors in printing occur. The pointer is then set at the center of the range and the knob tightened.

CODEBAR MECHANISM

4.46 A character to be printed is determined basically by the code combination set up on eight codebars (Figure 22). In order to position the codebars, the selection must first be set up in the selector blocking levers. The codebars must then be allowed to sense the blocking levers.

4.47 At the point when the selection is completed, the selector codebar clutch trip lever, in following its cam surface in the selector, rises and trips the codebar clutch. The

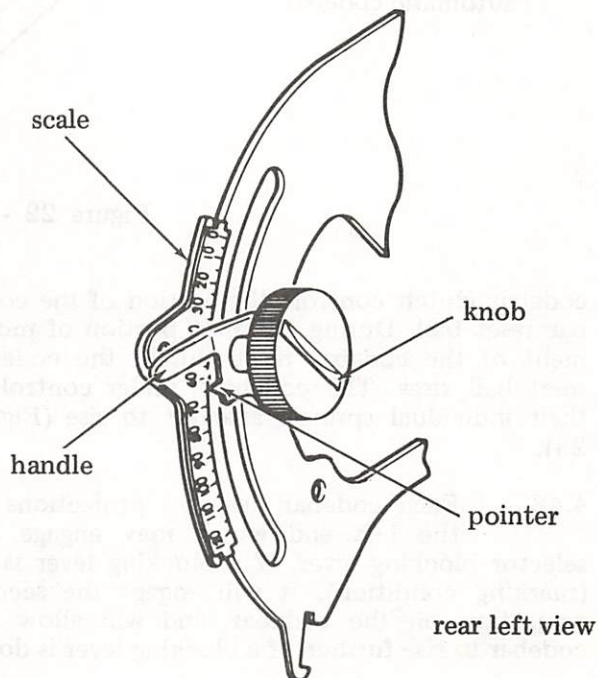

Figure 21 - Range Finder

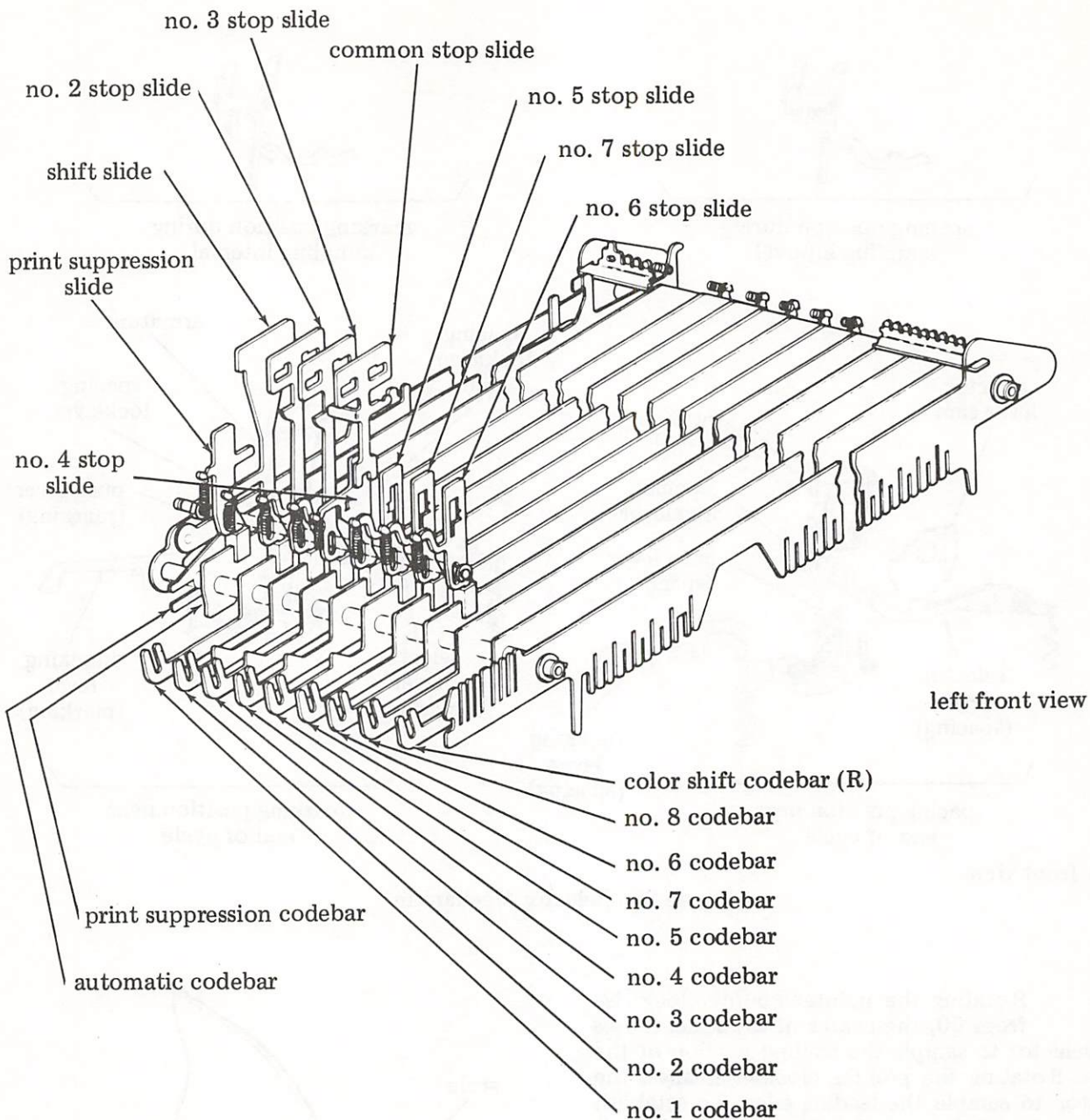

Figure 22 - Codebar Arrangement

codebar clutch controls the motion of the codebar reset bail. During the first portion of movement of the codebar reset clutch, the codebar reset bail rises. The codebars, under control of their individual springs, attempt to rise (Figure 23).

4.48 Each codebar has two projections on the left end which may engage the selector blocking lever. If a blocking lever is up (marking condition), it will engage the second projection on the codebar, and will allow the codebar to rise further. If a blocking lever is down

(spacing condition), it will engage the first projection on the codebar, and will not permit the codebar to rise (Figure 23).

4.49 A code selection is therefore transferred from the selector mechanism to the codebar mechanism in such a manner that a codebar associated with a marking pulse moves up, and a codebar associated with a spacing interval stays down. At the proper point during the rotation of a codebar reset clutch, a second cam surface trips the function clutch.

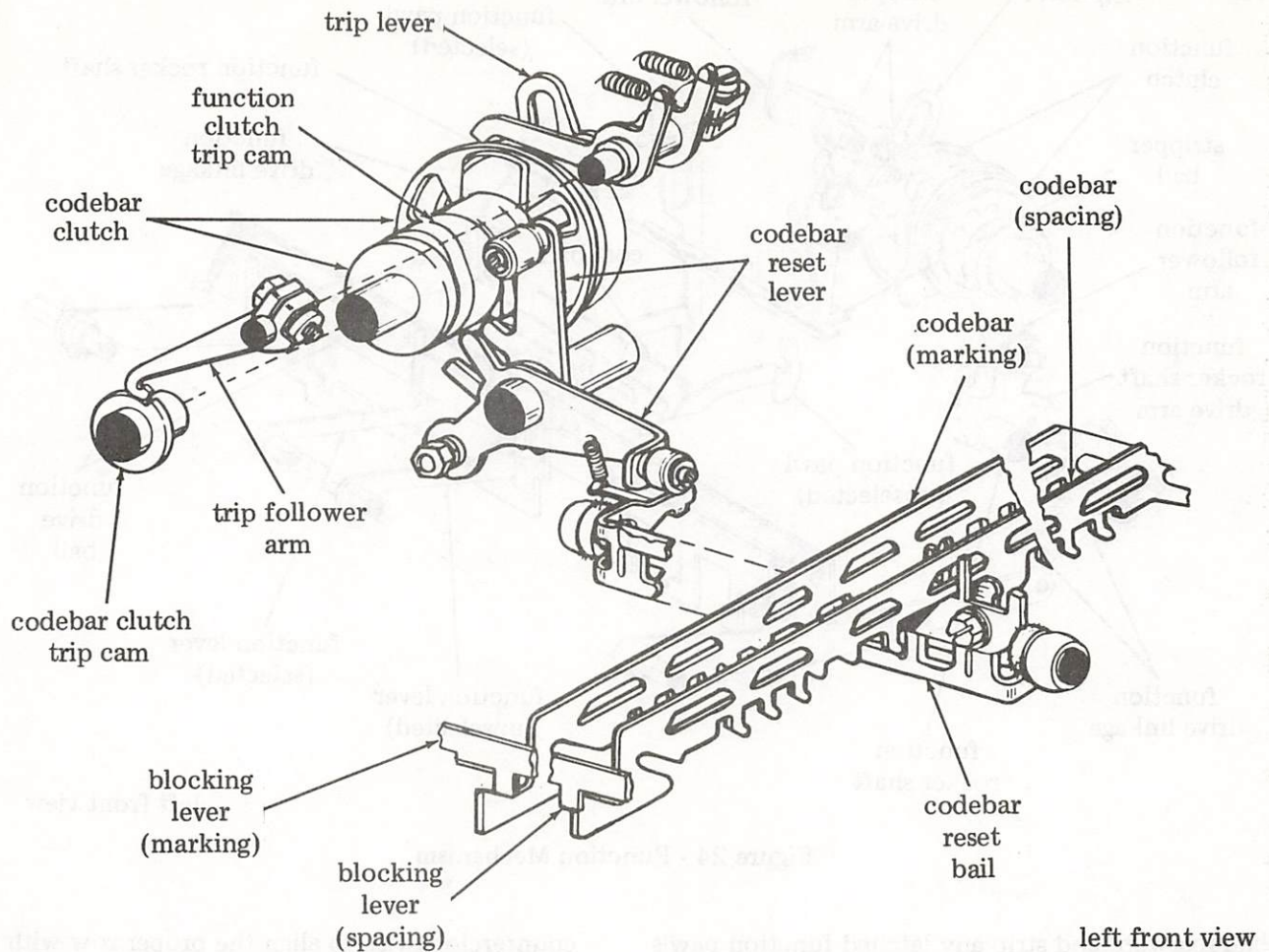

Figure 23 - Codebar Mechanism

FUNCTION MECHANISM

4.50 The function mechanism illustrated in Figure 24 enables the typing unit to perform functions at the receipt of the proper code combinations. Functions are operations supplementary to printing a message, such as carriage return and line feed.

4.51 Early in the codebar cycle, a cam pivots the function trip follower arm, which moves the function trip lever out of engagement with its shoe lever. The function clutch engages and makes one complete revolution. The function drive cam, through a follower arm and drive arm, causes the function rocker shaft to rock. The function rocker shaft, through two drive linkages, moves a function drive bail up during the first part of the cycle and down during the middle portion (Figure 24).

4.52 The underside of the codebars are coded by a series of notches and projections. Under the codebars are a number of

function levers which pivot on the same shaft as the function drive bail, and are connected to the bail by springs. As the bail moves up, the springs pull the function levers up so they sense the codebars. If a lever encounters one or more projections, it is retained in its down position against the tension of its spring. If the slots line up such that an opening is provided for a function lever, the lever moves all the way up to its selected position.

4.53 In most cases, when a function lever moves up to a certain level, it is latched by an associated function pawl. Then, when the function drive bail pulls the lever and latched pawl down during the middle portion of the cycle, the pawl provides the motion to effect the function.

4.54 Near the beginning of the function cycle, a cam pivots a drive arm which moves the function stripper bail frontward. Near the end of the cycle the cam permits the drive arm, under spring tension, to move the stripper

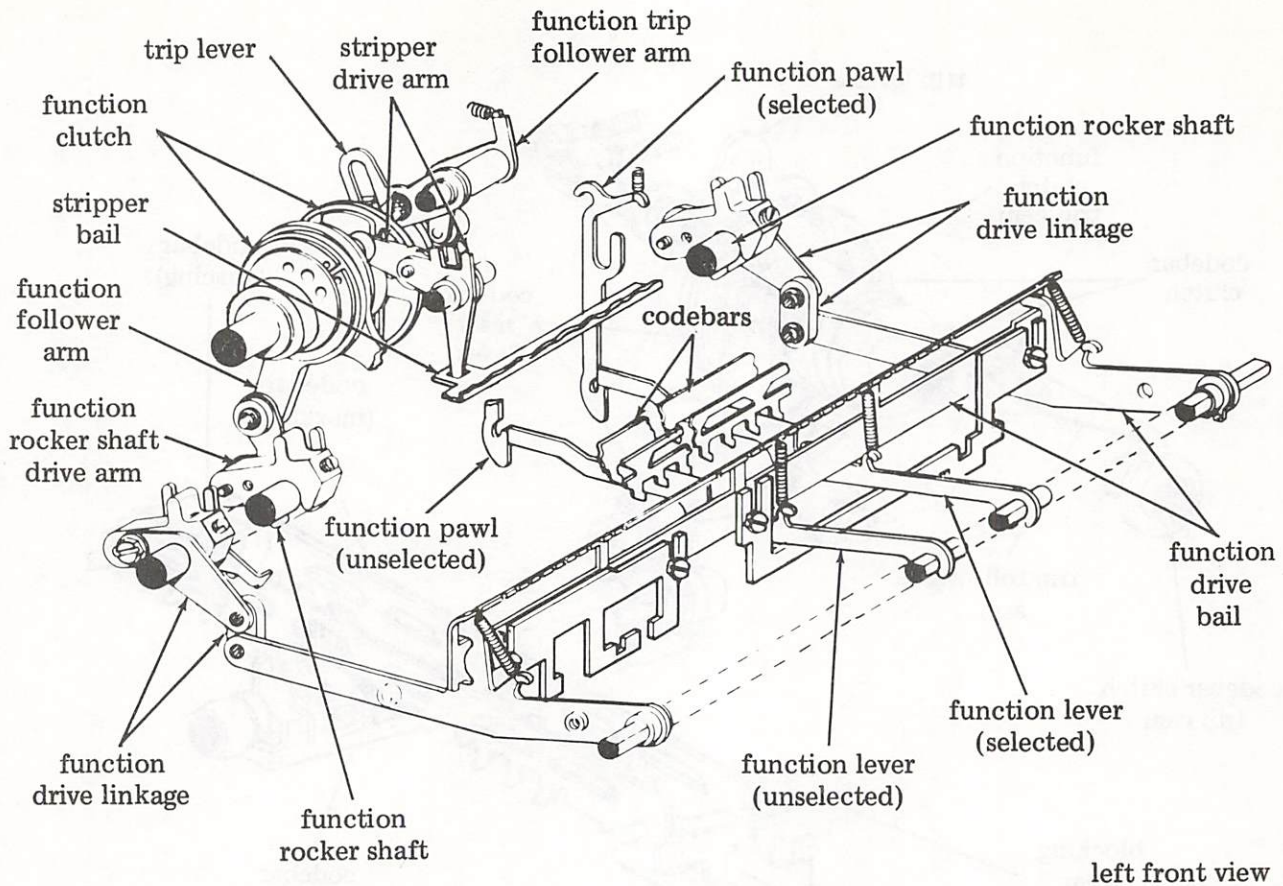

Figure 24 - Function Mechanism

bail rearward and strip any latched function pawls from their selected function levers.

4.55 The operation of the individual function levers and pawls is covered under the individual functions.

PRINTING MECHANISM

A. Type Wheel

4.56 The characters on the type wheel are arranged in sixteen positions around, and six positions vertically (Figure 9). The printing area shown in Figure 9 is the area where the selected character must be if it is to be printed when the print hammer strikes the type wheel. As shown in Figure 9, the borderline between the fields is under the printing area when the typing unit is in the stop condition.

4.57 During the first part of each function cycle, vertical and rotary positioning mechanisms impart separate but simultaneous motions to the type wheel to select the proper character. The rotary positioning mechanism rotates the type wheel either clockwise or

counterclockwise to align the proper row with the printing area. The vertical positioning mechanism raises the type wheel to the place for the proper character to print in the printing area. During the last part of the function cycle, the type wheel is returned to its stop position.

B. Motive Force

4.58 As the function clutch rotates, the associated eccentric cam starts an oscillating motion through the carriage drive link to the carriage drive bail (Figure 15). The bail pivots rearward during the first part of the cycle, and frontward to its stop position during the latter part. In doing this, it causes the power bail on the carriage to pivot first clockwise (as viewed from the left), then counterclockwise. The power bail has two rollers that move along the drive bail and permit it to receive the motion regardless of the carriage position along the printing line (Figure 25).

C. Rotary Positioning

4.59 Referring to Figure 26, the rotary positioning bail is held against the power bail by a spring. Connected to the rotary

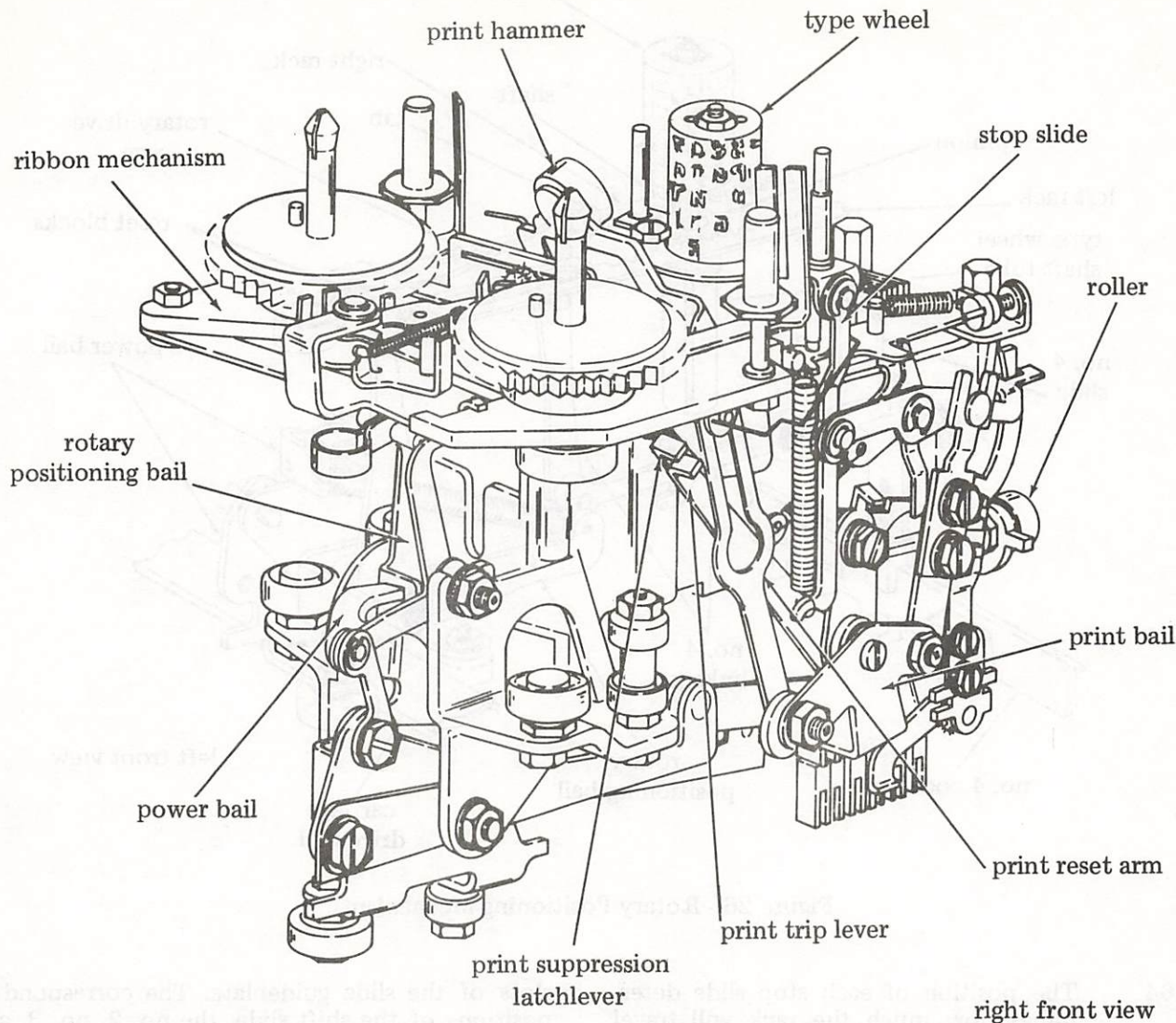

Figure 25 - Print Carriage Mechanism

positioning bail (at the top) is the rotary drive arm which pulls back on one of two racks. These racks are meshed with the pinion on the top hub of the type wheel shaft and tube.

4.60 As the power bail rotates, the rotary positioning bail rotates. The rotary drive arm is engaged with one of the racks and causes it to move, turning the pinion with which it is meshed (Figure 26). The pinion, being an integral part of the tube, turns the tube. The tube turns the cross pin fastened to the type wheel shaft and type wheel.

4.61 This motion continues until the end of one of the racks strikes a stop slide (Figure 27). At this time, the type wheel is correctly positioned in the rotational direction.

D. Degree of Rotation

4.62 How far the type wheel rotates in either direction is determined by the no. 1, no. 2, and no. 3 codebars. The no. 1 codebar controls the position of the shift slide, while the no. 2 and no. 3 codebars control the positions of the no. 2, no. 3, and common stop slides. These stop slides ride the codebars, and are up when the codebars are marking and down when the codebars are spacing (Figure 27).

4.63 The function of the stop slides is to stop either rack in its rearward travel. When a rack is stopped, the rotary drive bail stops, and the continuing motion of the power bail is dissipated by the spring.

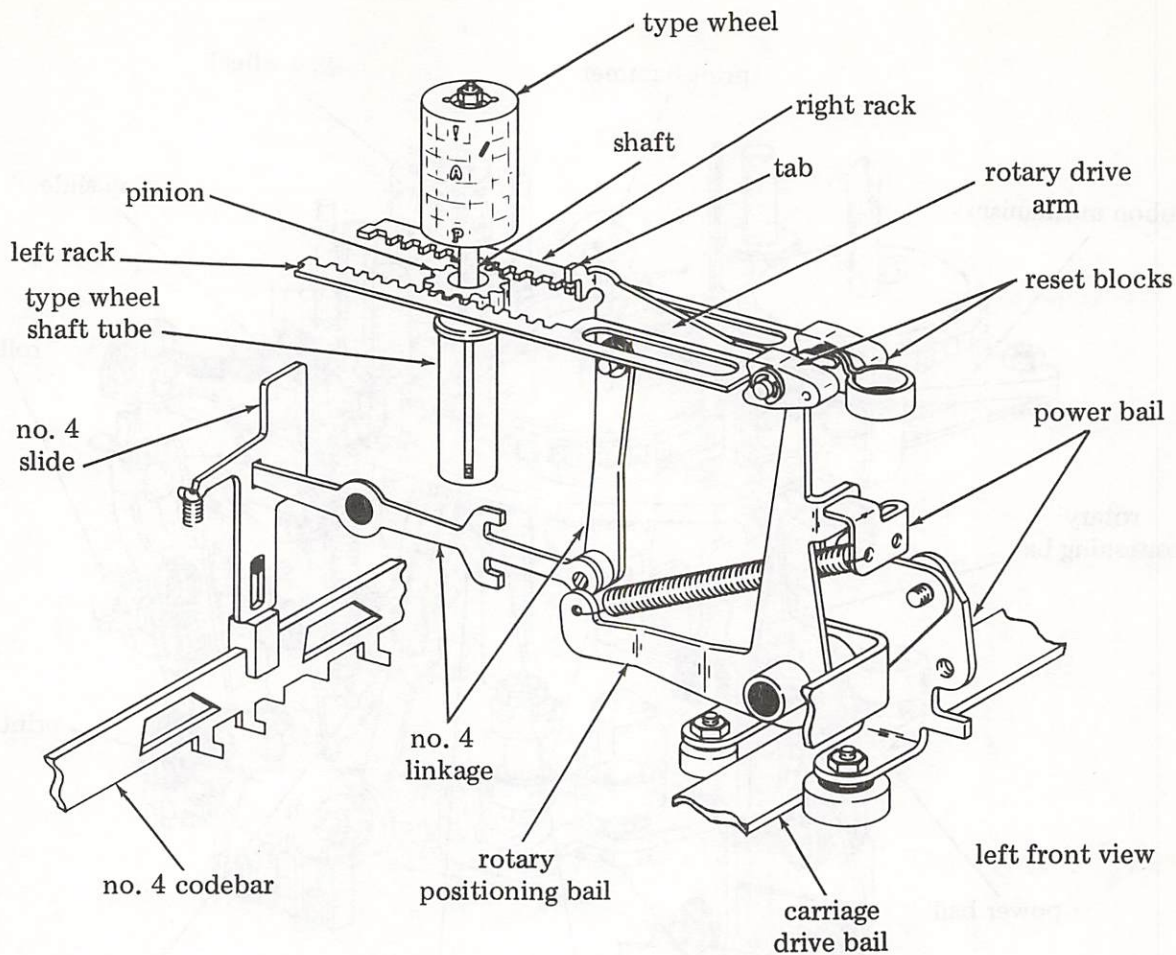

Figure 26 - Rotary Positioning Mechanism

4.64 The position of each stop slide determines how much the rack will travel before it is stopped. When a stop slide is down, it blocks the rack; when it is up, the rack will pass through a slot in the slide and continue to travel until blocked by another slide. The shift slide has no slot. It will block the rack whether it is up or down (Figure 27).

4.65 Depending on the position of the shift slide, the rack will travel to position either the odd or even rows of the type wheel. When the shift slide is up, the even rows are selected; when it is down, the odd rows are selected.

4.66 As mentioned in 4.62, the shift slide is controlled by the no. 1 codebar. When the no. 1 pulse is spacing, the no. 1 codebar and the shift slide are down. In this position, the shift slide is blocked by the front stop surface of the rotary stop plate (Figure 28). The no. 2, no. 3, and common stop slides remain locked in the

slots of the slide guideplate. The corresponding positions of the shift slide, the no. 2, no. 3, and common stop slide, will effect 7, 5, 3, and 1 rows of type wheel rotation respectively.

4.67 When the no. 1 pulse is marking, the no. 1 codebar and the shift slide are up. In this position, the shift slide is up, blocked by the rear stop surface of the rotary stop plate (Figure 28). The two slide guideplates, under spring tension, move to the rear. This positions all four stop slides to the rear effecting one additional row of type wheel rotation. Thus, the shift slide, the no. 2, no. 3, and common stop slides will effect 8, 6, 4, and 2 rows of type wheel rotation respectively.

E. Vertical Positioning

4.68 The vertical positioning mechanism, illustrated in Figure 29, positions the type wheel so that the proper character in the selected row is in the printing area at the time of printing.

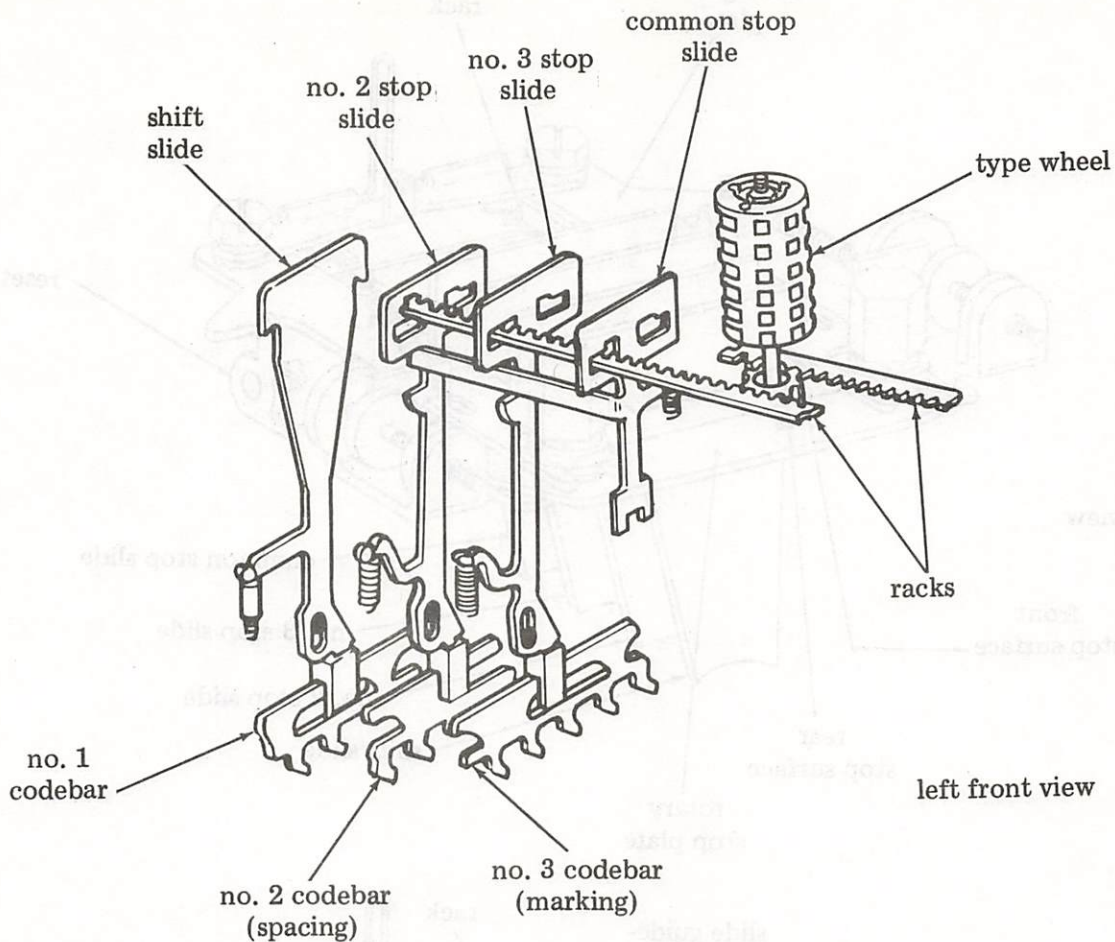

Figure 27 - Rotary Positioning Stop Slides

4.69 Vertical positioning is determined by the no. 5, no. 6, and no. 7 codebars, along with their associated stop arms. The marking codebars that effect printing in the first through sixth rows of the type wheel are as follows:

| <u>TYPE WHEEL ROW</u> | <u>CODEBAR (MARKING)</u> |
|-----------------------|--------------------------|
| 1 | 5, 6, and 7 Spacing |
| 2 | 5 and 6 |
| 3 | 7 |
| 4 | 5 and 7 |
| 5 | 6 and 7 |
| 6 | 5, 6, and 7 |

4.70 A vertical bail is held against the power bail by a spring. When the bails rock clockwise (as viewed from the left) during the first part of the function cycle, the vertical drive bail, through a drive arm, lifts the type wheel shaft and type wheel. How far the type wheel is

raised is determined by six stop arms that respond to the no. 5, no. 6, and no. 7 pulses. When the drive bail encounters an arm, it is stopped and its spring extends as the power bail continues to pivot. The type wheel shaft moves up and down the tube, and permits rotary motion to be transferred to the type wheel regardless of its vertical position.

4.71 When a code combination is received in which the no. 5, no. 6, and no. 7 pulses are spacing, the corresponding codebars and their respective slides remain down (spacing), and no motion is transferred to the stop arms. As the rear extension of the vertical drive bail rises, it strikes the C₁ stop arm, which is the longest (Figure 29). This permits the type wheel to be raised to the point where the first character in the selected row is in the printing area at the time of printing.

4.72 When the no. 5 and the no. 6 pulses are marking and the no. 7 pulse is spacing, the no. 5 and no. 6 codebars move their vertical slides up. The slides pivot the C₁, C₂, and 6 stop

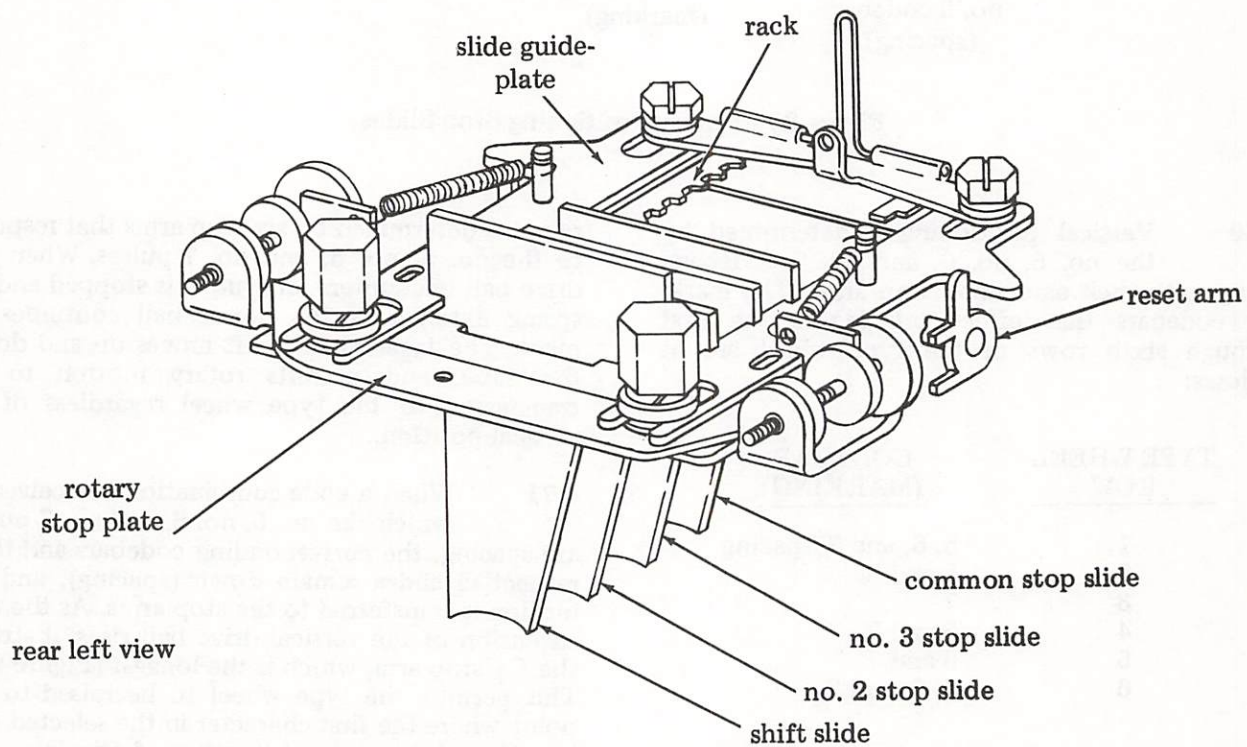
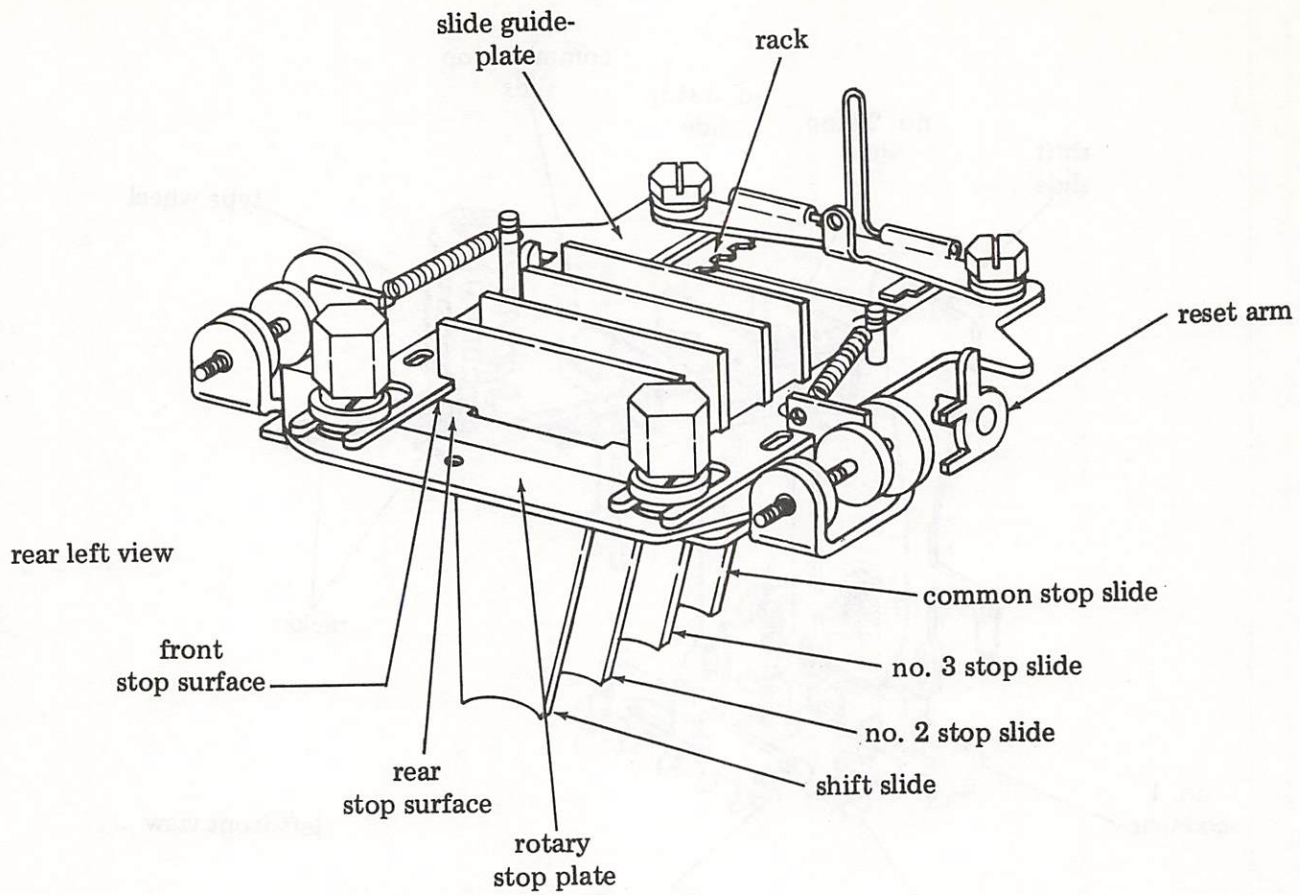

Figure 28 - Rotary Positioning Mechanism

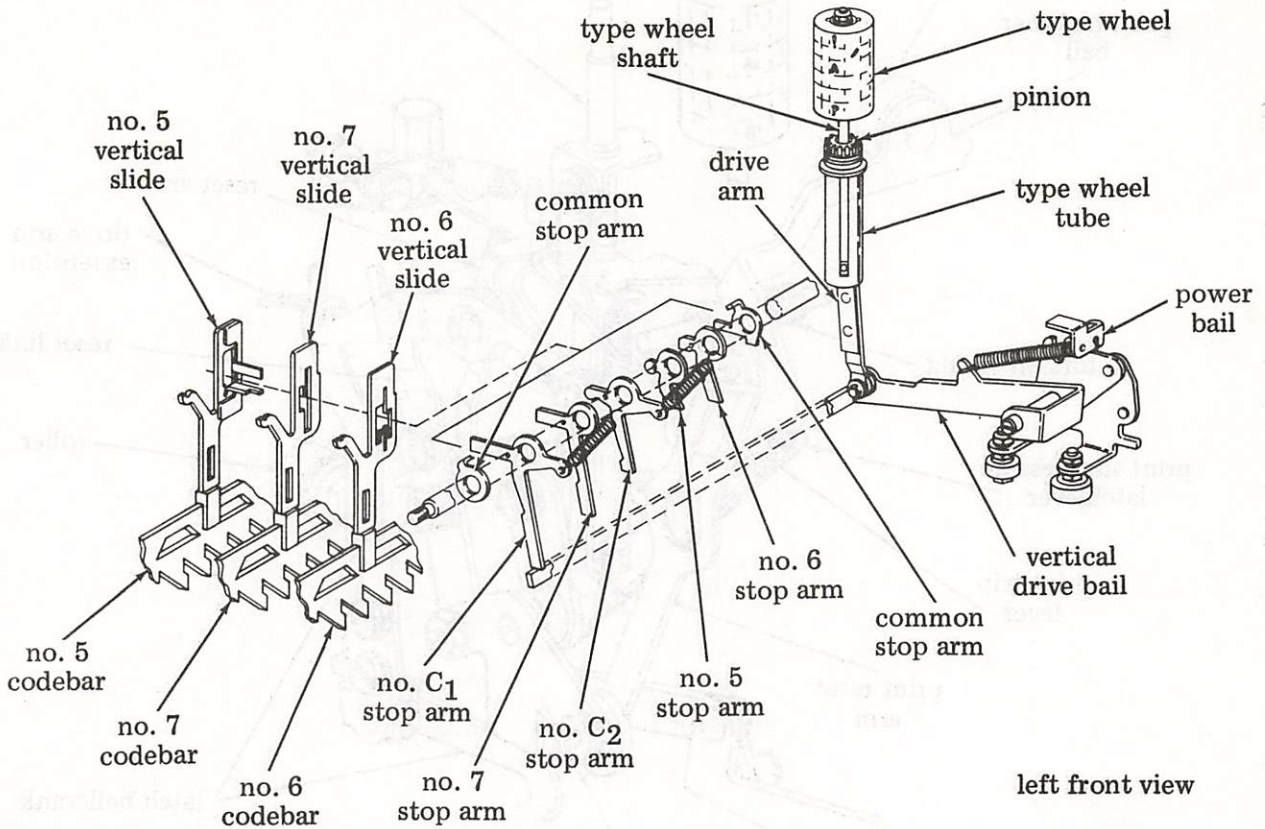

Figure 29 - Vertical Positioning Mechanism

arms rearward, out of the way of the drive bail. The bail strikes the no. 7 stop arm (the second longest), and the second character in the selected row is placed in the printing area.

4.73 When the no. 7 pulse is marking and the no. 6 and no. 5 are spacing, the no. 7 slide pivots the C_1 and no. 7 stop arms out of the way. The bail strikes the no. C_2 stop arm (the third longest), and the third character row is placed in the printing area.

4.74 When both the no. 5 and no. 7 pulses are marking and the no. 6 is spacing, three stop arms, C_1 , C_2 , and no. 7, are pivoted out of the way. The bail moves up until it strikes the no. 6 stop arm (the fourth longest), and the fourth character row is placed in the printing area.

4.75 When the no. 6 and no. 7 pulses are marking and the no. 5 is spacing, the C_1 , 7, C_2 , and 6 stop arms are pivoted out of the way. The bail moves up until it strikes the no. 5 stop arm (the second shortest), and the fifth character row is placed in the printing area.

4.76 When the no. 5, no. 6, and no. 7 pulses are marking, the C_1 , 7, C_2 , 6, and 5 stop arms are pivoted out of the way. The bail moves up and strikes the common stop arm (shortest), and the sixth character row is placed in the printing area.

F. Printing Mechanism

4.77 After the type wheel has been positioned, the printing mechanism illustrated in Figure 30 supplies the motion required to print the selected character. The motion is transferred through the proper levers, bails, springs, etc. to the rubber print hammer which strikes the type wheel forcing it against the ribbon and paper.

4.78 The print hammer is secured to the print hammer bail, and is located in front of the type wheel. The bail is latched by a lever extending down the right side of the carriage. When released, the print hammer flies forward under the action of the torsion spring, and hits the type wheel. Because the print hammer is made of a soft rubber, the type wheel is not damaged.

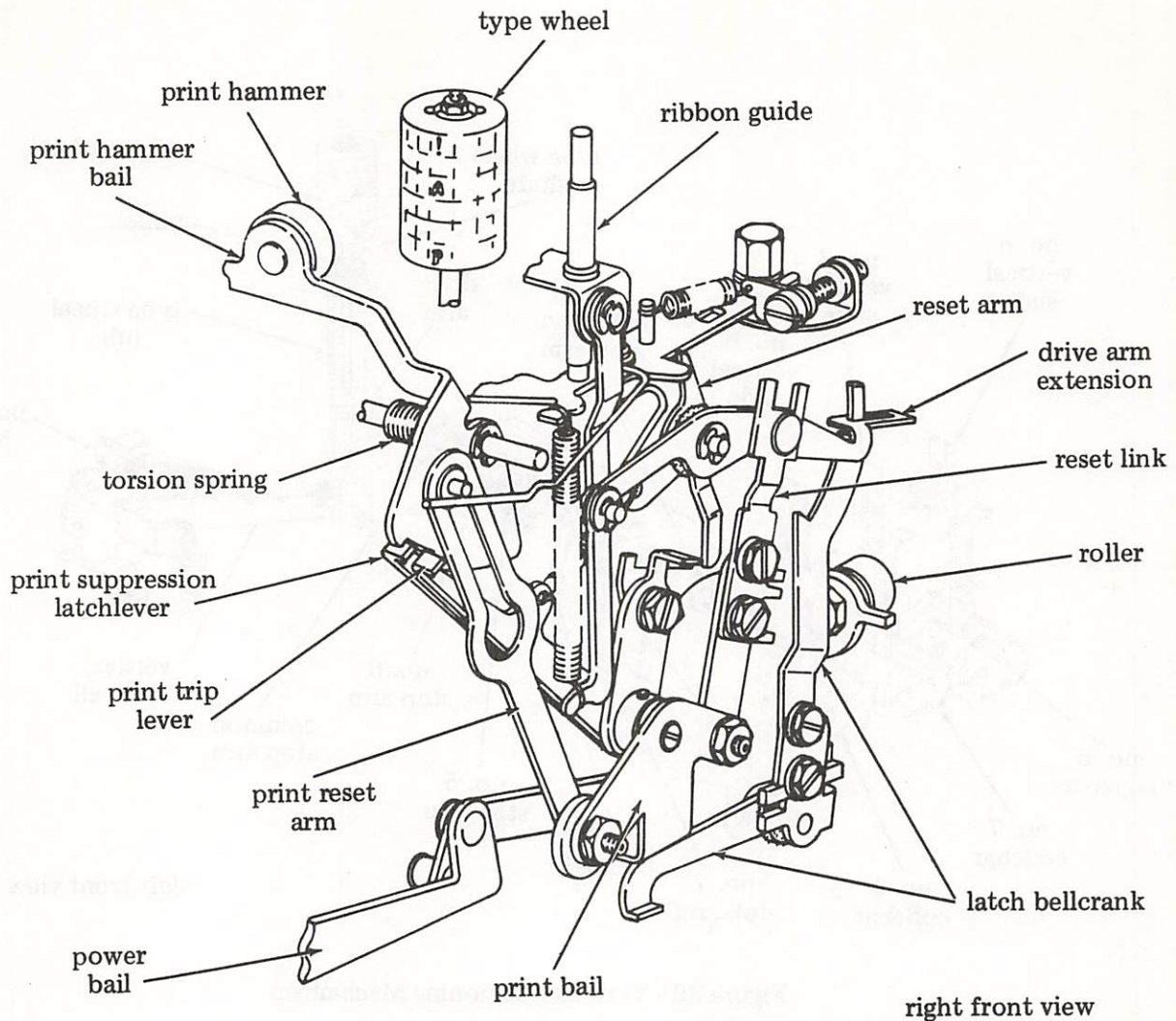

Figure 30 - Printing Mechanism

4.79 When the type wheel is struck, the type wheel and type wheel shaft rock forward and backward printing the selected character by impacting the ribbon and paper against the platen. Vertical and rotary positioning is not altered during printing.

4.80 During the last half of the cycle, the power bail returns the printing parts to their stop positions, and the print reset arm, attached to the print bail, returns the print hammer bail to its stop position. It is then latched by the print trip lever. Provisions are included to suppress printing during functions.

G. Printing Suppressed

4.81 The print suppression mechanism, illustrated in Figure 31, prevents printing whenever a function code combination is received.

4.82 As the codebars rise early in the codebar cycle, the print suppression codebar is held down by the print suppression latch. Early in the function cycle, after the function levers have been selected, the latch is pivoted away from the codebar by the print suppression cam on the function clutch.

4.83 If a function lever has not been selected, the print suppression codebar moves up and to the left, to its selected position. The print suppression slide follows the motion of this codebar and pivots the print suppression latchlever out of the way of the shoulder on the print hammer bail. Therefore, when the print trip lever releases the bail, its hammer is permitted to strike the type wheel and printing occurs.

4.84 If a function lever moves up to its selected position, it engages one of a series of notches in the print suppression codebar.

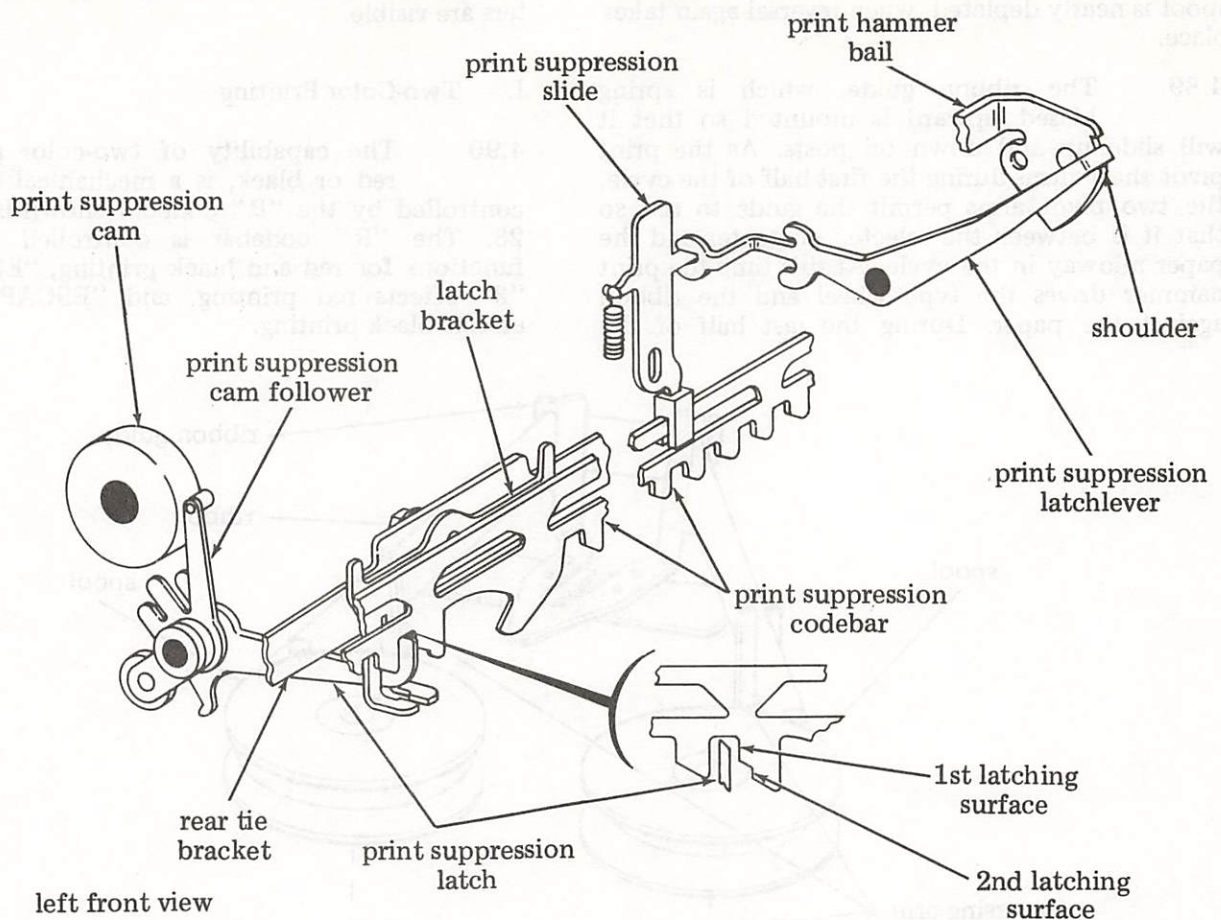

Figure 31 - Print Suppression Mechanism

When the latch releases the codebar, the selected function lever prevents it from moving all the way to its selected position. Therefore, the print suppression latchlever is not pivoted and catches the shoulder when the hammer bail is released by the trip lever. The hammer does not reach the type wheel, and printing is suppressed.

4.85 As the selected function lever moves down and withdraws from the notch in the print suppression codebar, the latch, which has been returned to its stop position, engages a second latching surface on the codebar. This prevents the codebar from rising when the function lever is withdrawn, causing printing to occur before the print hammer is completely reset in its stop position. The print suppression codebar is completely reset with the rest of the codebars at the end of the codebar cycle, and at that time, the latch engages the first latching surface.

H. Ribbon Mechanism

4.86 The ribbon mechanism (Figure 32) supplies the ink for printing. As the typing unit operates, the mechanism feeds the

ribbon from one spool to the other, and reverses the direction of feed when the spool is nearly depleted.

4.87 As the power bail rocks during the first part of the function cycle, it pivots the ribbon power lever which moves the ribbon drive lever rearward. The feed pawl rides on the drive lever and acts on a ratchet to rotate a ribbon spool. A check pawl drops into the succeeding tooth and detents the ratchet until it is again rotated during the next operation.

4.88 The mechanism continues to rotate one spool until the other is nearly depleted. An eyelet in the ribbon then engages the ribbon reversing arm. As the eyelet is pulled against the arm, the latter moves to a point where a detent spring shifts it to its alternate position, where one of its reversing extensions falls ahead of an extension on the feed pawl. As the pawl moves frontward during the last half of the cycle, it strikes the arm extension and is pivoted to its alternate position against the other ratchet. In doing so, it strikes an extension on the check pawl and pivots it to its alternate position against

the other ratchet. The depleted spool is now rotated to take up the ribbon until the other spool is nearly depleted, when reversal again takes place.

4.89 The ribbon guide, which is spring biased upward is mounted so that it will slide up and down on posts. As the print pivot shaft turns during the first half of the cycle, the two pivot arms permit the guide to rise so that it is between the selected character and the paper midway in the cycle. At this time the print hammer drives the type wheel and the ribbon against the paper. During the last half of the

cycle, the pivot arms retract the guide and ribbon to their stop position so that the printed characters are visible.

I. Two-Color Printing

4.90 The capability of two-color printing, red or black, is a mechanical function controlled by the "R" codebar shown in Figure 23. The "R" codebar is controlled by two functions for red and black printing; "ESCAPE" "3" effects red printing, and "ESCAPE" "4" effects black printing.

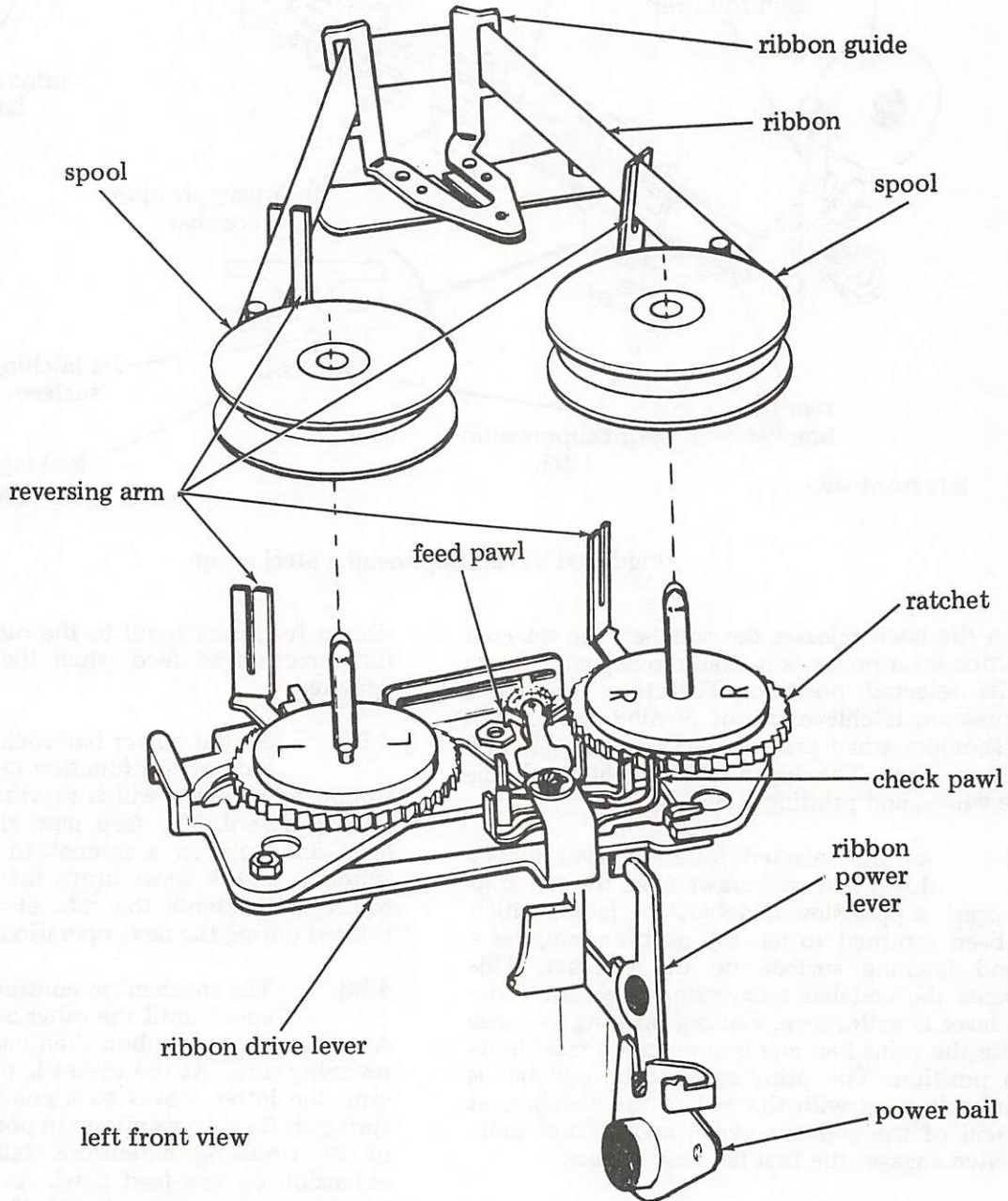

Figure 32 - Ribbon Mechanism

4.91 When the function "ESCAPE" "3" is received (local or remote), the "R" codebar moves up and engages the lower extension of the latch bellcrank (Figure 30). The latch bellcrank pivots, allowing the drive arm to move the ribbon guide up. Printing will then occur in the lower half of the ribbon, or red.

4.92 When the function "ESCAPE" "4" is received (local or remote), the "R" codebar remains down, and the latch bellcrank does not move. The latch bellcrank remains latched by the drive arm extension, preventing the ribbon guide from moving up. Printing then occurs in the upper half of the ribbon, or black.

SPACING MECHANISM

4.93 The spacing mechanism (Figure 33) positions the carriage so that the printed characters are horizontally in line on the paper. Each time a character is printed, the carriage is positioned one character to the right. Spacing is suppressed on all functions except "space" when spacing occurs and printing is suppressed. At the end of the printed line, spacing is suppressed and the typing unit overprints. When the "carriage return" function is received, the carriage is returned to the left margin.

NOTE: With the automatic carriage return-line feed feature, spacing is not suppressed at the end

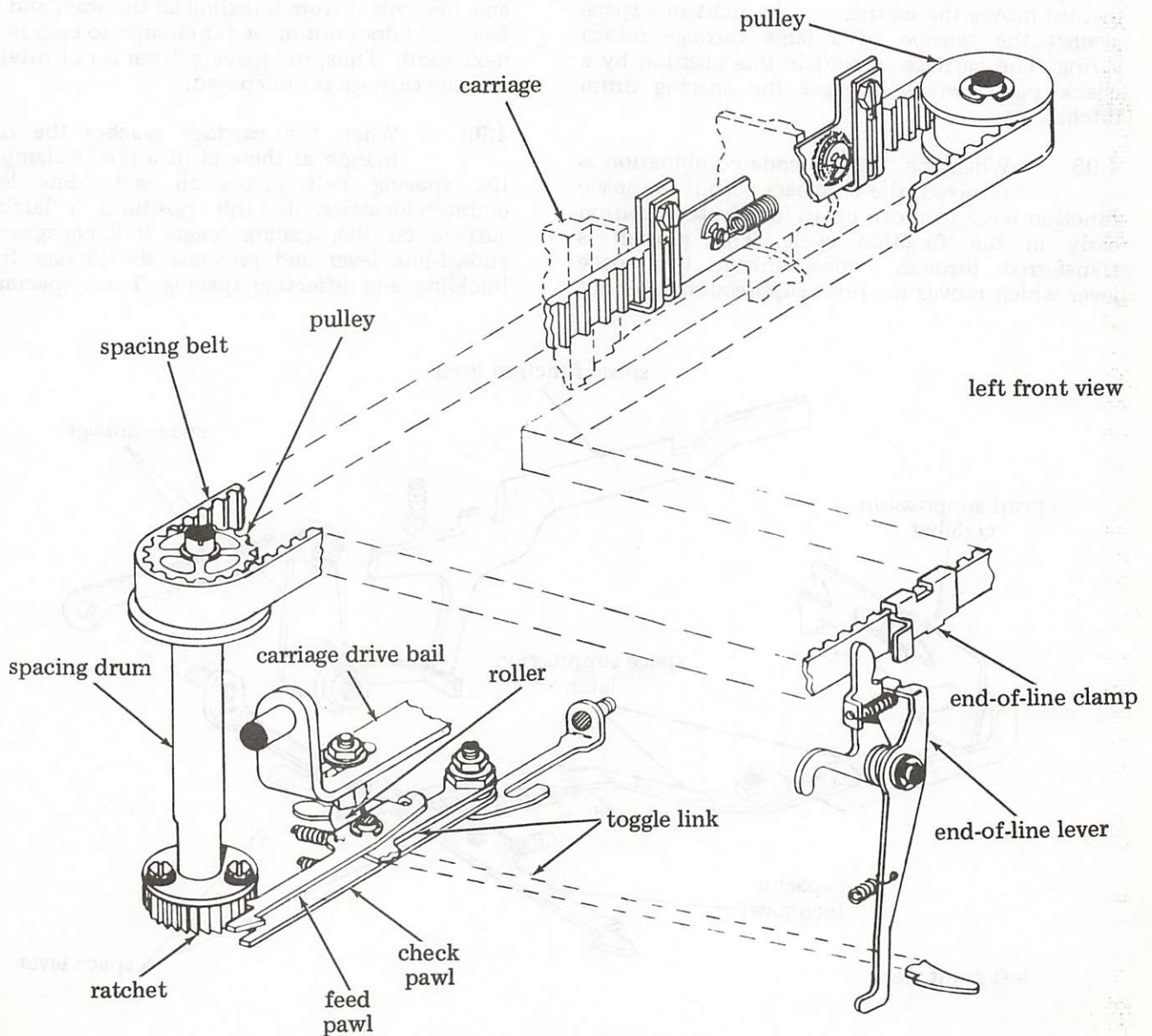

Figure 33 - Spacing Mechanism

of a line. Also, the typing unit does not overprint at the end of a line. The carriage is returned automatically to the left margin when it reaches a predetermined point.

4.94 As the carriage drive bail moves rearward during the first part of the function cycle, a small roller mounted near the left end permits a toggle linkage consisting of a spacing feed pawl and toggle link to buckle rearward under spring tension. The feed pawl moves to the right and engages the next tooth on the ratchet. The ratchet is part of the spacing drum. When the roller moves towards the front during the other part of the cycle, it unbuckles the toggle linkage, and the pawl is moved to the left and rotates the drum one tooth. This motion is imparted by a pulley at the top of the drum to a spacing belt which is looped around a pulley on the right side of the typing unit. The spacing belt in turn moves the carriage to the right one space against the tension of a large carriage return spring. The carriage is held in this position by a check pawl, which engages the spacing drum ratchet.

4.95 When the "space" code combination is received, the codebars permit the space function lever to move up to its selected position early in the function cycle. This motion is transferred, through a space linkage, to a space suppression latch which moves the print suppression latch out

of the way of the toggle linkage. The spacing linkage buckles completely and spacing takes place as described, while printing is suppressed.

SPACE SUPPRESSION

4.96 On every function except "space," spacing as well as printing must be suppressed (Figure 34). When a character to be printed is received, the print suppression codebar moves up and to the left. In doing so it pivots a space suppression latch so that it is moved to the right, out of the way of the toggle linkage. This permits the linkage to buckle and effect spacing.

4.97 On the other hand, when a function is received, the print suppression codebar remains down and to the right, and does not pivot the space suppression latch. In this position, the space suppression latch engages the toggle linkage and prevents it from buckling all the way, and the feed pawl does not move far enough to engage the next tooth. Thus, the spacing drum is not rotated, and the carriage is not spaced.

4.98 When the carriage reaches the right margin at the end of a line, a clamp on the spacing belt pivots an end-of-line lever counterclockwise. In this position, a latching surface on the spacing toggle link engages the end-of-line lever and prevents the linkage from buckling and effecting spacing. Thus, spacing is

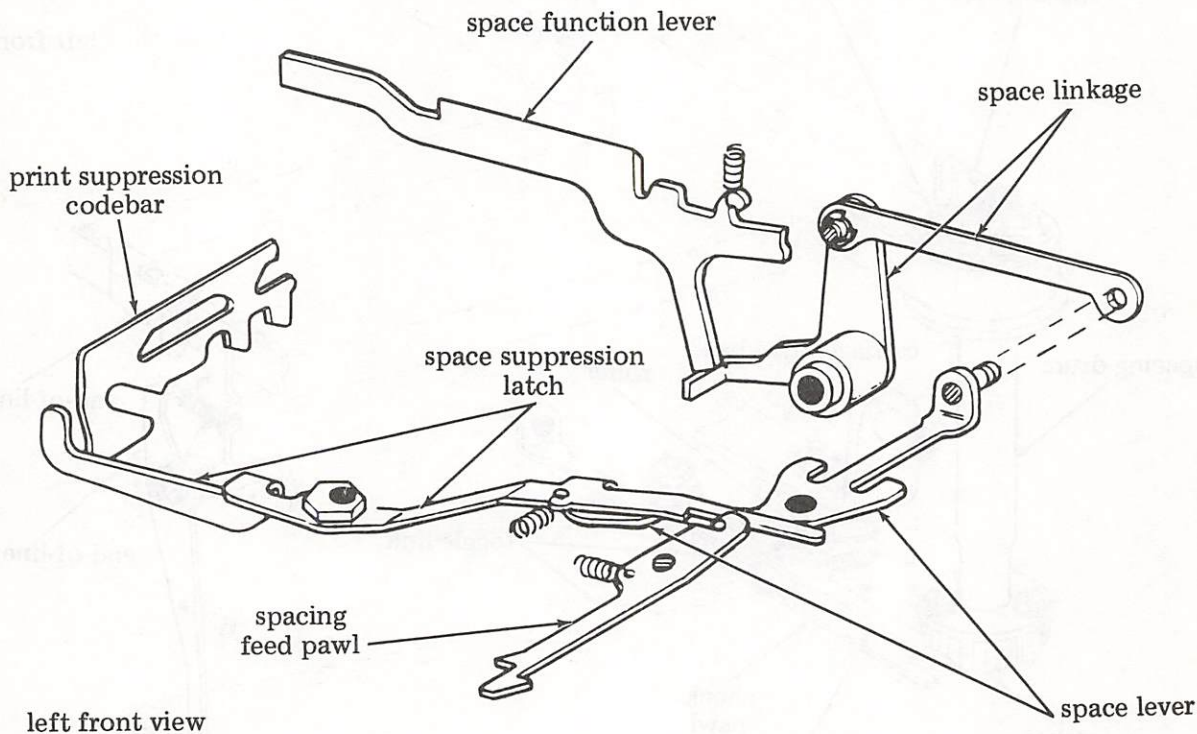

Figure 34 - Space Function and Space Suppression Mechanism

suppressed, and the typing unit overprints at the right margin until the "carriage return" code combination is received.

NOTE: With the automatic carriage return-line feed feature, spacing is not suppressed at the end of a line. Also, the typing unit does not overprint at the end of a line. The carriage is returned automatically to the left margin when it reaches a predetermined point.

CARRIAGE RETURN

4.99 When the "carriage return" code combination is received, the carriage return function lever moves up to its selected position, and engages the carriage return function pawl (Figure 35). As the function bail moves the lever and pawl down during the middle portion of the cycle, an extension on the pawl drives the carriage return actuating lever down also. This

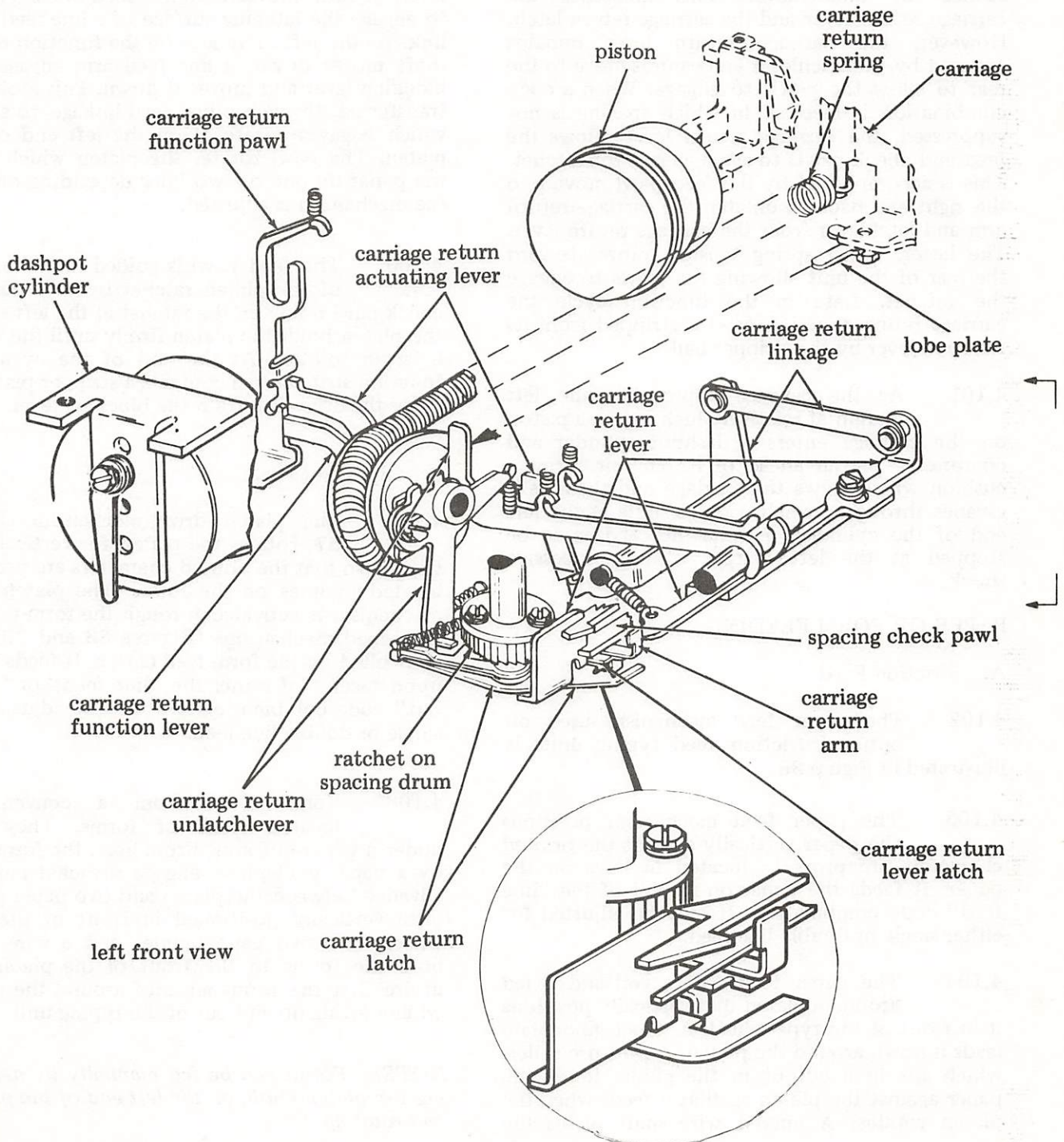

Figure 35 - Carriage Return Mechanism

motion is transferred by means of linkages to the carriage return lever. In moving frontward, the carriage return lever is latched by both the carriage return latchlever and carriage return latch.

4.100 In moving frontward, the carriage return lever also disengages the spacing pawl and check pawl from the spacing drum ratchet. The carriage return spring then pulls the carriage back to the left margin. As the carriage nears the left margin, a lobe plate on the carriage strikes the unlatchlever. This unlatches the carriage return lever and the carriage return latch. However, the carriage return lever remains engaged by the latchlever and cannot move to the rear to allow the pawls to engage. When a code combination is received in which spacing is not suppressed, the carriage return lever allows the feed and check pawls to again engage the ratchet. This is accomplished by the feed pawl moving to the right and back to unlatch the carriage return arm and latchlever from the carriage return lever. The latter, under spring tension, moves toward the rear of the unit allowing the pawls to engage the ratchet. Late in the function cycle the carriage return function pawl is stripped from its function lever by the stripper bail.

4.101 As the carriage approaches the left margin at relatively high speed, a piston on the carriage enters a dashpot cylinder and compresses the air ahead of it. The air forms a cushion which slows the carriage and then, as it escapes through a small, variable hole at the left end of the cylinder, permits the carriage to be stopped at the left margin without excessive shock.

PAPER OR FORM FEEDING

A. Friction Feed

4.102 The paper feed mechanism used on optional friction feed typing units is illustrated in Figure 36.

4.103 The paper feed mechanism positions the paper vertically so that the printed characters are properly located in lines on the paper. It feeds the paper on receipt of the "line feed" code combination. It may be adjusted for either single or double line feed.

4.104 The paper feeds off a roll and is led around a platen that vertically positions it in front of the type wheel. A paper guideplate leads it down around the platen. A pressure roller, which sits in a cutout in the guide, holds the paper against the platen so that it feeds when the platen rotates. A curved wire shaft biases the

pressure roller and the guideplate against the paper. The pressure is released by a lever on the right end of the shaft. The paper is held around the front of the platen by a wire guide and is led up out of the typing unit by a deflector guide. It can be manually fed by a knob on the left end of the platen.

4.105 When the "line feed" code combination is received, the codebars permit the line feed function lever to move up to its selected position early in the function cycle. The function lever, in turn, moves up a line feed blocking lever to engage the latching surface of a line feed drive link. As the left drive arm on the function rocker shaft moves down, a line feed arm engages the blocking lever and moves it down. This motion is transferred, through a line feed linkage, to a pawl which engages a ratchet on the left end of the platen. The pawl rotates the platen which feeds the paper up one or two lines depending on how the mechanism is adjusted.

4.106 The feed pawl is guided into the teeth of the platen ratchet by two posts. A check pawl riding on the ratchet at the left side of the platen holds the platen firmly until the platen is again rotated. At the end of the cycle, the function stripper bail contacts a stripper plate and strips the drive link from the blocking lever.

B. Sprocket Feed

4.107 The platen drive mechanism (Figure 37) rotates the platen for vertical positioning so that the printed characters are properly located in lines on the forms. The platen drive mechanism is activated through the form-out and form-feed mechanisms (Figures 38 and 39), and controlled by the form-feed clutch. It feeds forms upon receipt of either the "line feed" or "form-out" code combination and may be adjusted for single or double line feed.

4.108 Forms feed from a conveniently located stack of forms. They feed under a paper-out arm. From here, the forms, led by a paper guideplate, engage sprocket pins and advance between the platen and two paper guides until vertically positioned in front of the type wheel. The two paper guides and a wire guide hold the forms to the front of the platen and insure that the forms advance around the platen while moving up and out of the typing unit.

NOTE: Forms can be fed manually by depressing the platen knob, on the left end of the platen, and rotating it.

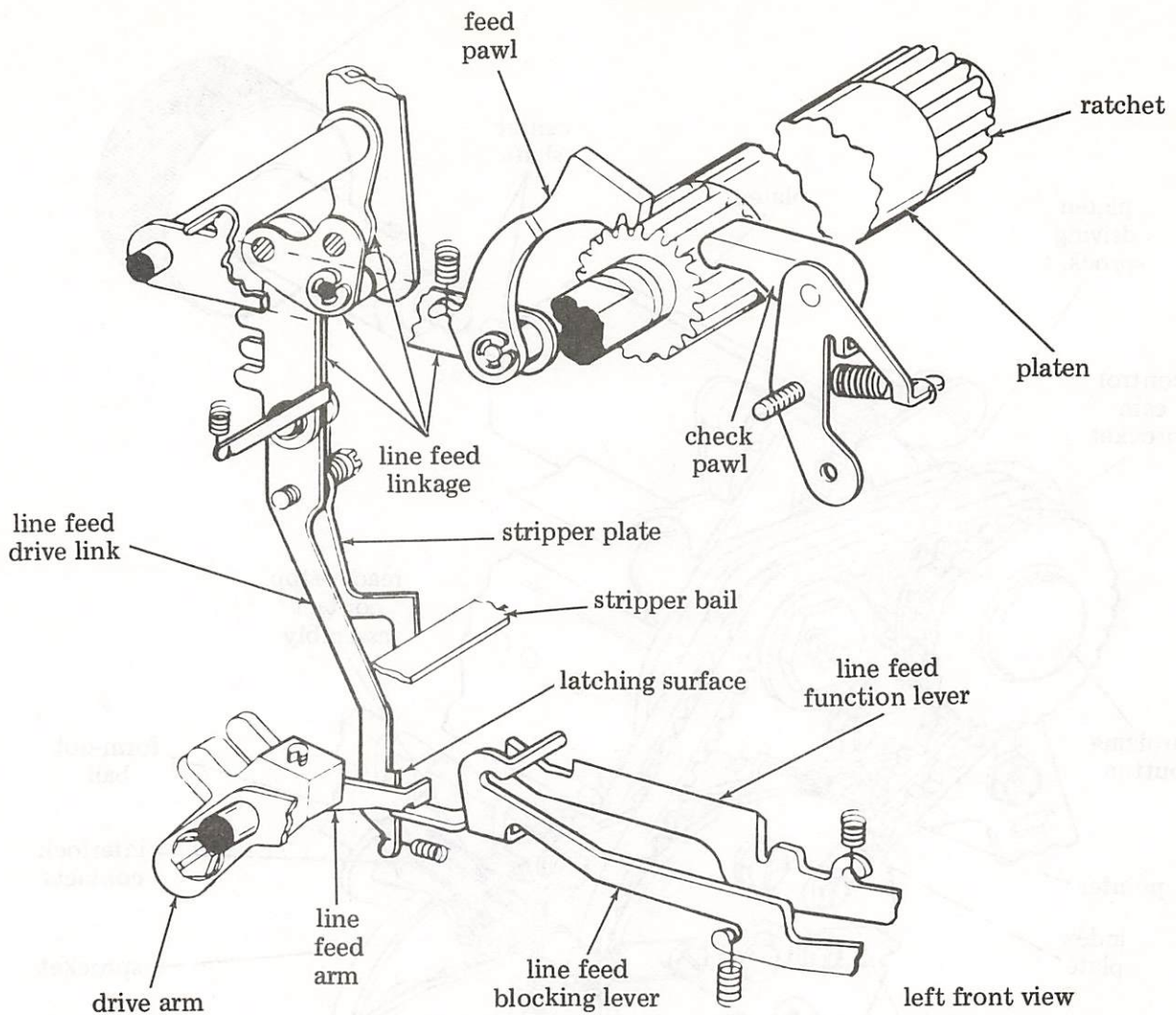

Figure 36 - Paper Feed Mechanism (Friction Feed)

4.109 Form Feed — Single Line Feed (Figure 38): With the line feed selector lever in single line feed position, the left stripper adjusting screw is positioned downward blocking the pivotal action of the stripper lever. During the function cycle the line feed pawl is pulled down, pulling the line feed extension lever down. Since the stripper lever can pivot a small amount, the line feed pawl is stripped by the strip lever extension soon after it has engaged, with the result that the line feed lever extension travels downward a small amount which is, however, sufficient to trip the form-out clutch and affect line feed. The form-out clutch will be disengaged again at the next trip point.

4.110 Form Feed — Double Line Feed (Figure 38): With the line feed selector in the double line feed position, the left stripper adjusting screw is moved up. This allows the stripper lever to pivot a greater amount (than for single line feed). During the function cycle the

line feed pawl is pulled down, pulling the line feed extension lever down. Because the stripper lever can pivot, the stripper lever extension will not strip the function pawl right away, but will allow it to move downward a greater amount than before (ie, in single line feed mode). This additional travel of the line feed pawl results in the line feed lever tripping the form-out clutch for a longer time, affecting double line feed.

4.111 The number of lines the form advances depends on how much the clutch rotates before it is disengaged. If the clutch becomes disengaged at the first shoe lever, the form will advance one line; if the clutch becomes disengaged at the second shoe lever, the form will advance two lines; and so on. The amount of clutch rotation depends on how soon the strip pawl comes in contact with the line feed lever. This time will depend upon the distance between the strip pawl and the line feed lever. When the distance is small the clutch will trip and engage

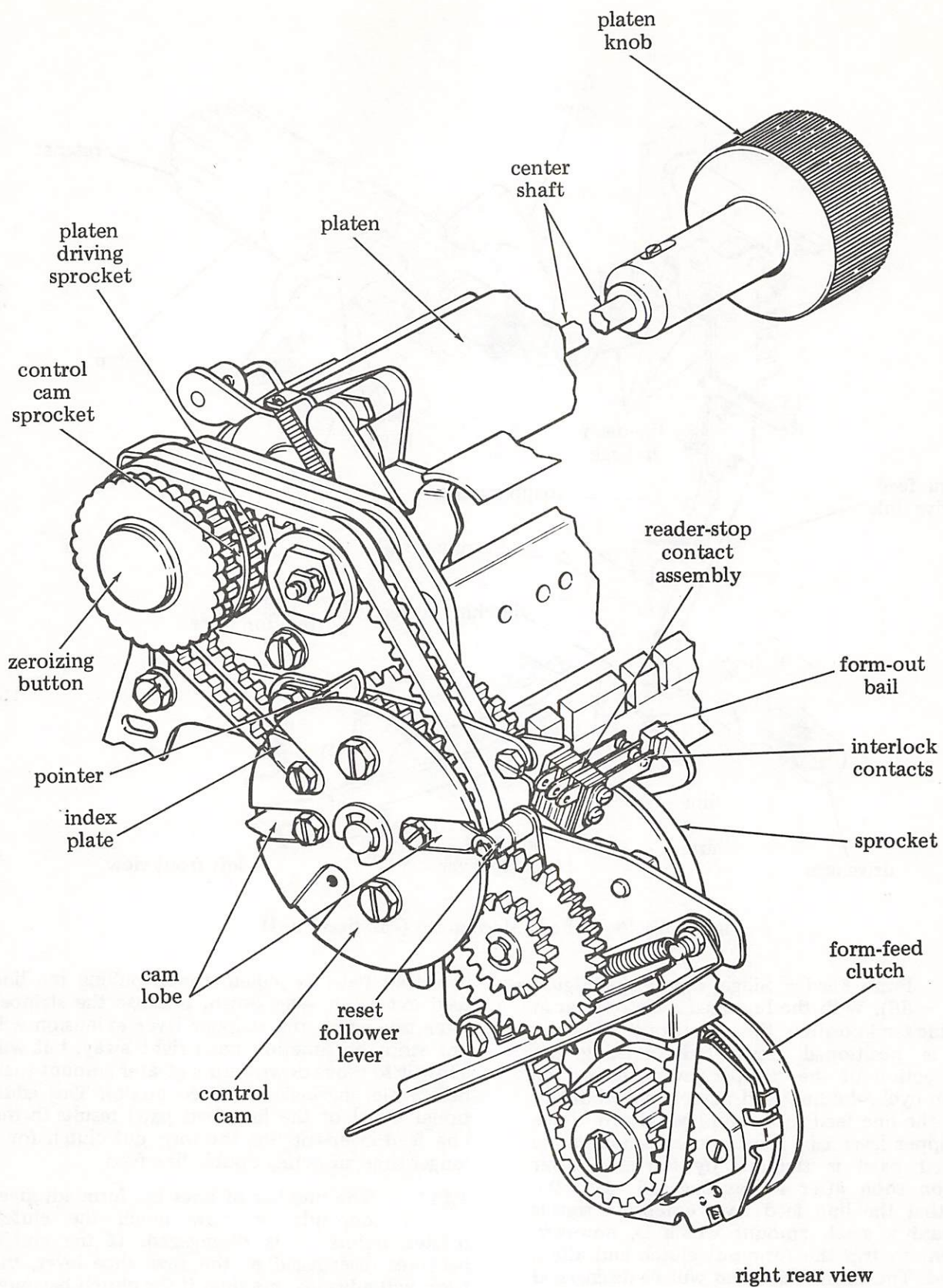

Figure 37 - Platen Drive Mechanism (Sprocket Feed)

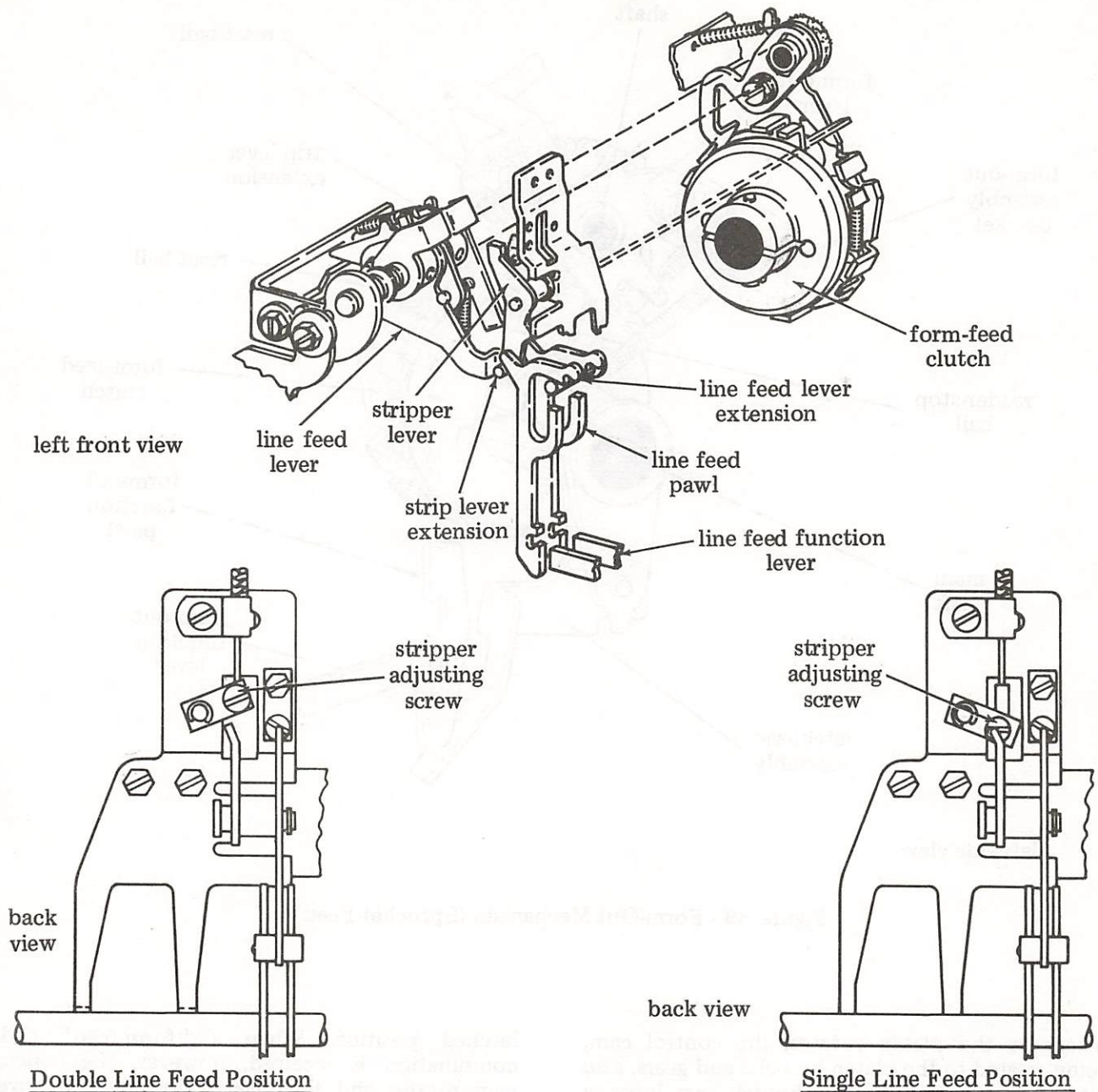

Figure 38 - Form-Feed Mechanism (Sprocket Feed)

sooner, rotating a greater amount before it is disengaged. Double line feed will result. If the distance is greater the clutch will trip and engage later, rotating a smaller amount before it is latched. Single line feed will result.

4.112 **Form Out:** When the typing unit receives the "form-out" code combination, the form-out function lever (Figure 39) moves up to engage the form-out function pawl. During the function cycle the pawl is pulled down. This action pivots the latchlever assembly which becomes disengaged from the form-out lever. Due to spring tension the form-out lever pivots to the rear. An extension on the form-out

lever pivots the trip lever extension which in turn moves the clutch trip lever away from the clutch shoe lever. The form-feed lever engages and remains engaged throughout the form-out cycle.

4.113 When engaged, the clutch drives the platen drive mechanism which consists of belts, gears, and sprockets. The platen drive mechanism is illustrated in Figure 37.

4.114 As long as the form-out lever stays pulled to the rear by spring tension, the form will advance except as regulated by the control cam of the platen drive mechanism.

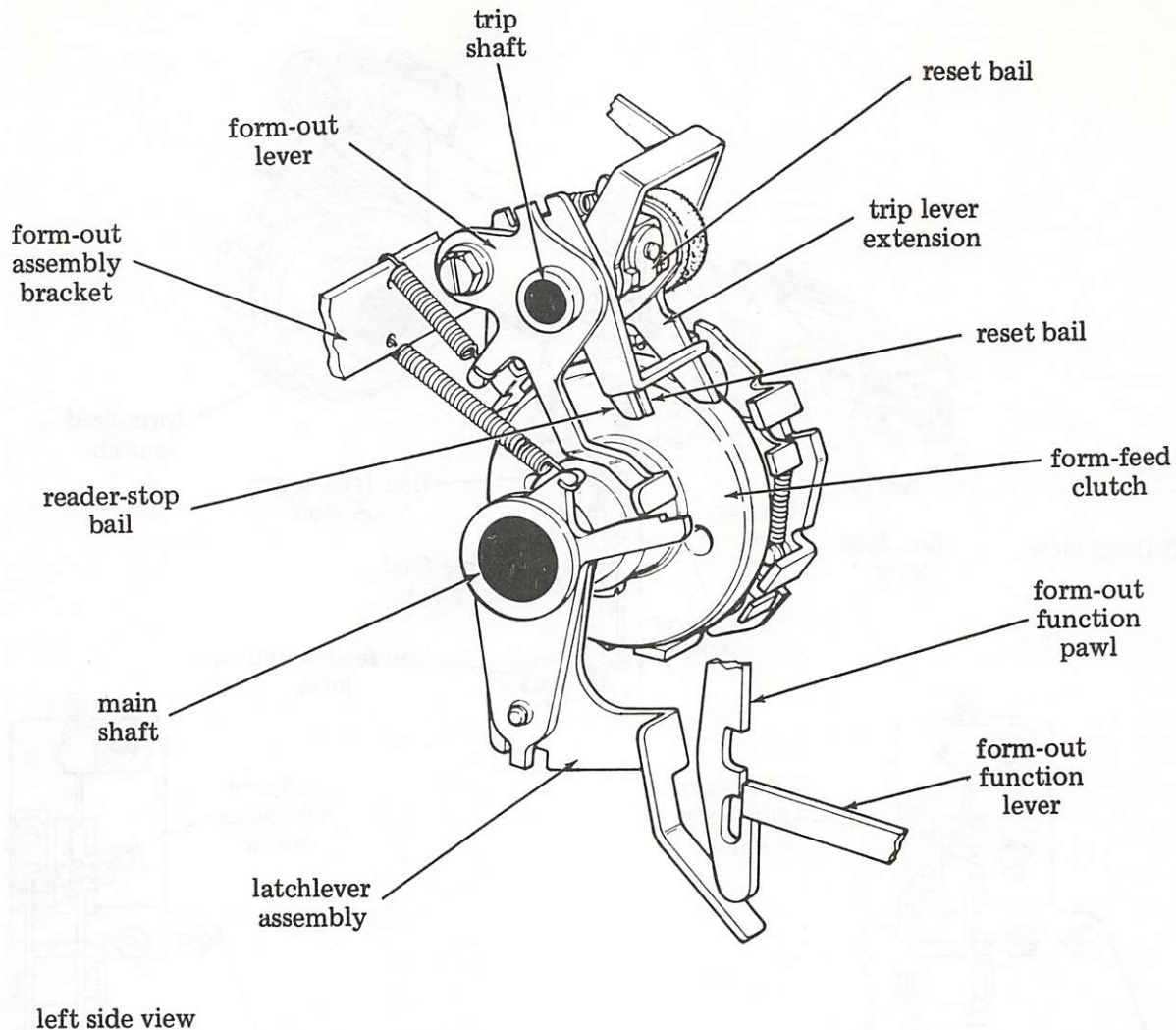

Figure 39 - Form-Out Mechanism (Sprocket Feed)

Whenever the platen rotates, the control cam, being related to the platen by belts and gears, also rotates. The rotating cam, through cam lobes, a reset follower lever, and a reset bail, initiates the action to terminate the advance of the platen and thus the form-out cycle.

4.115 When a cam lobe contacts the reset follower lever and rotates it toward the rear, a reset bail also rotates and pivots the form-out lever extension away from the trip lever extension. The trip lever engages a shoe lever and disengages the clutch, terminating form-out.

4.116 With the form-out just terminated, the reset follower lever remains on the high part of a cam lobe, and the form-out lever is blocked by the reset bail from rotating to its

latched position. When a "form-feed" code combination is received, however, the control cam rotates and the reset follower lever moves from the high part of the cam lobe. This causes the reset bail to rotate downward and move away from the form-out lever extension. As a result, the form-out lever is permitted to latch. The typing unit can now receive another "form-out" command.

NOTE: It is in order to allow the cam lobe to clear the reset follower lever that a "form-feed" command is given before another form-out cycle can begin.

4.117 The gearing on the platen drive mechanism varies to accommodate various size forms.

4.118 When the platen drive mechanism advances the form one or two lines during "form feed" the cam lobe rotates an equivalent distance. Then, when "form-out" is received the rest of the form will be advanced with the cam lobe merely rotating until it strikes the reset follower lever.

4.119 The control cam can have three lobes with the result that the form may be advanced one-third the distance for which the gears were installed. For example, if the gears on the platen drive mechanism were designed to advance a form of a certain length, by installing cam lobes, this length can be varied to smaller lengths.

4.120 When an Automatic Send-Receive Teletypewriter Set receives a "form-out" code combination, the form-out bail (Figure 37) is rotated toward the front by the form-out lever extension. This action causes the interlock contacts of the reader stop contact assembly to be operated with the following results:

(a) A pair of normally closed contacts are opened during the "form-out" function. This stops the tape reader from transmitting and prevents characters "on the fly" from being printed.

(b) A pair of normally open contacts are closed. This keeps the typing unit motor operating in case the typing unit is turned off before the form-out cycle is completed. Thus, synchronization of the forms is maintained.

4.121 The form can be manually advanced any length by pressing the platen knob inward and rotating the knob (Figure 37).

MARGIN BELL AND END-OF-LINE BELL

A. Margin Bell

4.122 As the carriage moves to the right during printing, the carriage upper rear roller makes contact with and depresses a latch which is secured to a lever mounted on the rear rail. As the latch is depressed, the lever is rotated and moves the automatic carriage return-line feed codebar to the right a short distance, where a notch in the codebar permits the bell function lever to move up to its selected position, where it is latched by its function pawl. During the middle portion of the function cycle, the lever moves the pawl down against the pressure of the latter spring. When the stripper bail strips the pawl late

in the function cycle, the pawl moves up and causes a clapper mounted on a wire spring to snap up and ring a gong.

B. End-of-Line Bell

4.123 End-of-line bell operation proceeds in the same manner as above, except that a projection on the carriage picks up the automatic carriage return-line feed codebar at a predetermined point and moves the codebar to the right a short distance until a notch in the codebar permits the bell function lever to move up to its selected position.

BACKSPACE MECHANISM

4.124 The backspace mechanism is part of the APL (A Programming Language) sets. It is also available as a separate option. The function of the backspace mechanism is to backspace the printing carriage one character so that overstrike characters can be generated.

4.125 The backspace mechanism (Figure 40) achieves backspace by moving the feed pawl and check pawl away from the ratchet. The entire backspace function is accomplished in two parts; half a character backspaced during the first part of the printer cycle, and half in the second part of the printer cycle.

4.126 When the backspace function is received, the feed pawl and check pawl are completely disengaged from the ratchet allowing the carriage to move to the left half a character, after which the backspace pawl engages the ratchet. As the printer completes its cycle, the backspace pawl is moved away from the ratchet and the carriage moves to the left the other half character.

4.127 When the backspace code combination is received, the backspace function lever rises and picks up its pawl which is then driven downward. This action of the function pawl is transferred to an actuating lever by means of an extension on the backspace function pawl. As this actuating lever moves downward, it rotates the carriage return lever through the backspace and carriage return bails and the carriage return link. This movement of the carriage return lever is sufficient to free the feed pawl and check pawl from the spacing ratchet, but not enough movement is imparted to latch up the carriage return function.

4.128 As the backspace function pawl approaches its lowest point of travel, the pawl is stripped off by the stripper bail. This stripping action causes the feed pawl and check pawl to return to the spacing ratchet.

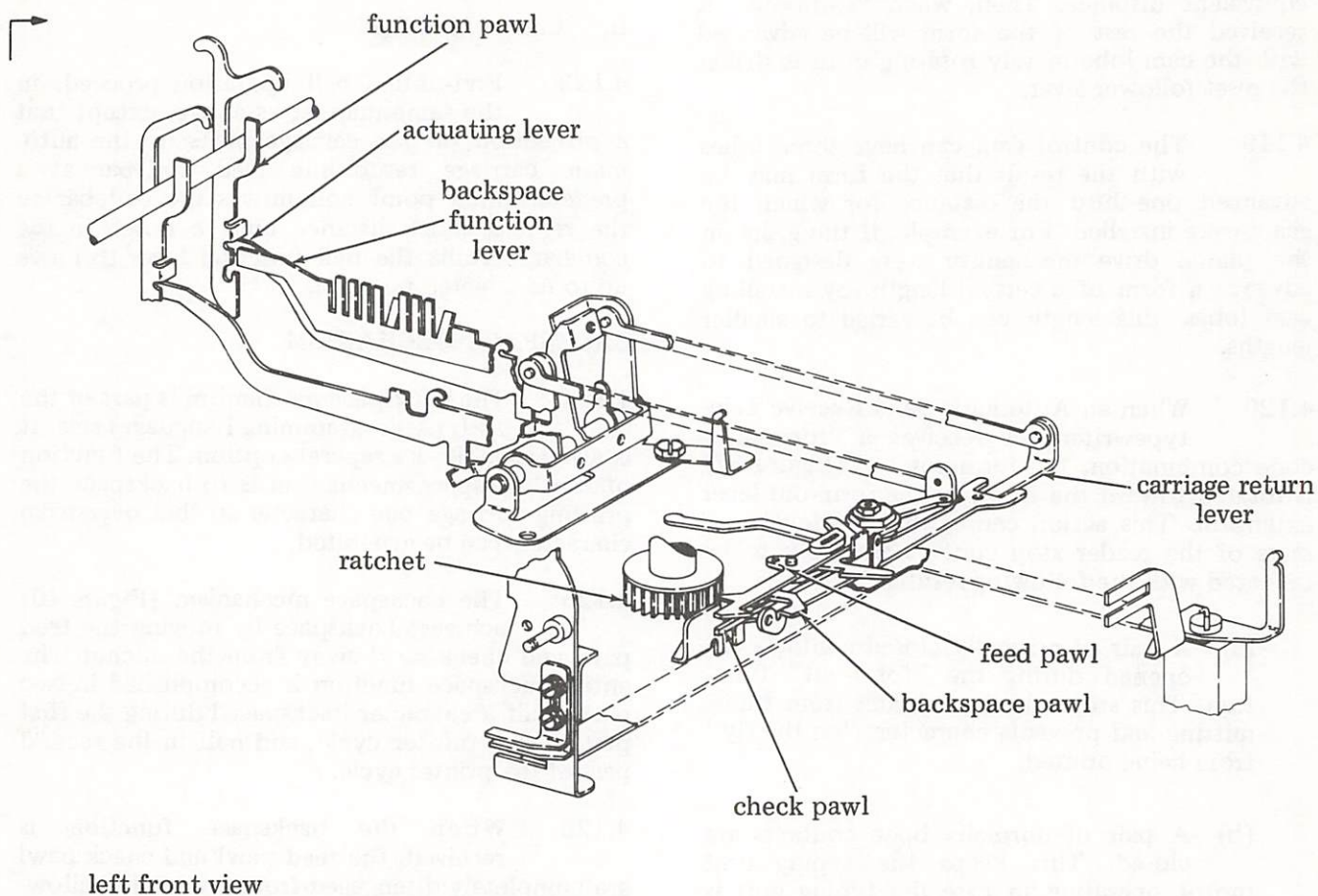

Figure 40 - Backspace Mechanism

4.129 During a carriage return function, the backspace pawl is held away from the spacing ratchet so that should a carriage return-backspace sequence be sent, the printer does not malfunction.

5. OPTIONS

AUTOMATIC CARRIAGE RETURN/LINE FEED

5.01 With this customer-activated option, carriage return and line feed will automatically occur after the 132nd character on wide

platen units, and after the 72nd character on standard platen units. To enable the automatic carriage return/line feed feature, the disabling clips on the function lever guide must be removed (Figure 41) as follows:

| | |
|-------------------------|----------------|
| Narrow platen friction: | slot A |
| Narrow platen sprocket: | slots A and L |
| Wide platen: | slots A and AD |

NOTE: The function box casting should be used as a guide for locating the proper slots in the function lever guide.

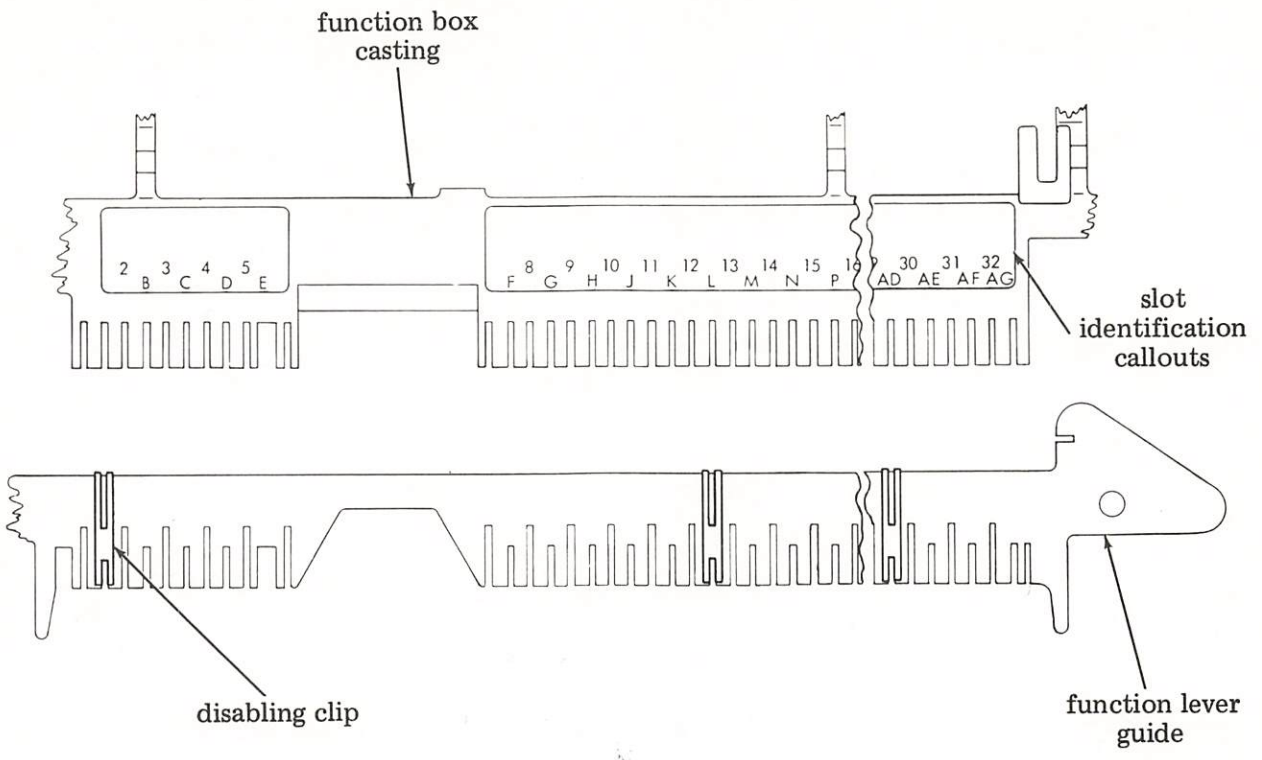

Figure 41 - Disabling Clip Location

38 PRINTER
 LUBRICATION

| CONTENTS | PAGE | CONTENTS | PAGE |
|----------------------------------------|------|----------------------------------------------------------------------------------------------------------------------------------------------------------------------------------------------------------------------------------------------------------------------------------------------------------------------------------------------------------------------------|------|
| 1. GENERAL | 1 | Trip lever | 8 |
| 2. BASIC UNIT | 2 | Trip shaft | 3 |
| COMMON MECHANISMS | 2 | Type wheel mechanism | 16 |
| Armature | 18 | SPROCKET FEED | |
| Automatic codebar | 9 | MECHANISMS | 21 |
| Blocking levers | 18 | Cam, pulley, and gear | |
| Carriage area | 13 | combination | 22 |
| Carriage rear rail | 17 | Form-out mechanism | 23 |
| Carriage return and | | Line feed clutch | 24 |
| spacing levers | 12 | Paper feed area | 20 |
| Codebars | 9 | Platen mechanism | 21 |
| Codebar clutch | 4 | Platen drive area | 22 |
| Dashpot | 14 | 3. VARIATION TO BASIC UNIT | 24 |
| Disc and brushes | 6 | Answer-back area | 24 |
| Distributor area | 6 | Answer-back mechanism | 25 |
| Drive arm | 15 | Backspace mechanism | 26 |
| Drive mechanism | 11 | Trip magnet | 25 |
| Function area | 8 | 1. GENERAL | |
| Function clutch | 3 | 1.01 This section provides lubrication procedures for the Model 38 Printer. It is reissued to make some corrections, to change the lubrication interval, and to include lubricating instructions for the backspace mechanism. Marginal arrows indicate the changes and additions. To remove the printer as a unit from the teletypewriter, refer to Section 574-400-702TC. | |
| Function levers | 9 | 1.02 Lubrication of the printer is presented by mechanisms. Photographs show numbered callouts which correspond to paragraphs containing line drawings. The line drawings show the specific points of each mechanism to be lubricated. | |
| Function rocker shaft | 5 | 1.03 References to front, rear, left, right, etc, are made viewing the printer from its normal operating position. | |
| Function shaft area | 5 | 1.04 Lubricate the printer before placing it in service, and just before placing it in storage. After about 100 to 200 operating hours, | |
| Intermediate gears | 4 | | |
| Latchlever | 7 | | |
| Latchlever and trip lever | 19 | | |
| Main shaft area | 2 | | |
| Motor area | 4 | | |
| Print hammer | 15 | | |
| Pushlevers and stripper bail | 18 | | |
| Reset arm | 15 | | |
| Reset bail | 10 | | |
| Ribbon guide spring | 17 | | |
| Ribbon mechanism | 16 | | |
| Rocker and pawls | 10 | | |
| Selector area | 17 | | |
| Selector clutch | 19 | | |
| Selector levers | 19 | | |
| Slides | 14 | | |
| Slide guideplates | 14 | | |
| Spacing area | 11 | | |
| Space bellcrank | 11 | | |
| Spacing mechanism - 1 | 12 | | |
| Spacing mechanism - 2 | 13 | | |
| Stop bail | 7 | | |
| Stripper drive lever | 9 | | |

→ relubricate printer. Thereafter, lubricate every 750 operating hours or six months, whichever occurs first.

CAUTION: DISCONNECT POWER BEFORE APPLYING ANY LUBRICANT. DO NOT USE SOLVENTS TO CLEAN PLASTIC PARTS OR PROTECTIVE FINISHES. USE A SOFT DRY CLOTH. IF NECESSARY, USE A SOFT DAMP CLOTH WITH MILD DETERGENT, THEN RINSE AND BUFF WITH A SOFT DRY CLOTH.

1.05 Whenever the printer is disassembled, apply an equally well-mixed coat of KS7470 oil and KS7471 grease to the areas indicated below:

- Eccentric Cams (2.02 and 2.04)
- Adjusting Tab (2.11)
- Cam Roller (2.13)
- H-Plate (2.13)
- Codebar Shafts (2.17 and 2.18)
- Spacing Gear (2.23)
- Selector Cam (2.44)
- Platen Shaft (2.46)

NOTE: Whenever clutches are disassembled, apply a thin coat of KS7471 grease to the shoe lever spring loops, and KS7470 oil to the internal mechanisms.

1.06 The following symbols, and their meaning, apply to the lubrication points in each paragraph:

| <u>SYMBOL</u> | <u>MEANING</u> |
|---------------|--------------------------------------------|
| D | Dry — no lubricant permitted |
| G | Grease — apply KS7471 grease as instructed |
| O | Oil — apply KS7470 oil as instructed |

1.07 Lubricate the printer thoroughly. Saturate all felt washers and oilers, and apply oil to each end of all springs. Apply oil to points where it will adhere and not run off. Avoid overlubrication. Keep electrical contacts and wire insulations free of lubricants. In general, apply oil to hollow shafts, wicks, and locations where parts rub, slide, or move with respect to each other. Apply grease to gear teeth and points of heavy pressure.

2. BASIC UNIT

COMMON MECHANISMS

2.01 Main Shaft Area

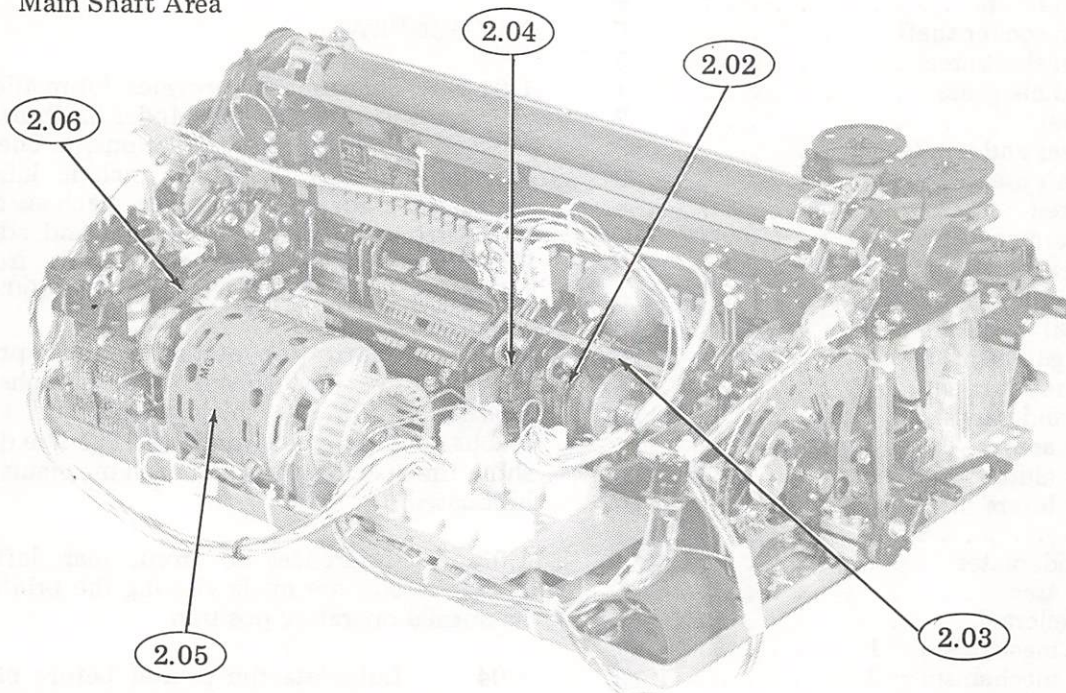

left rear view

2.02 Function Clutch

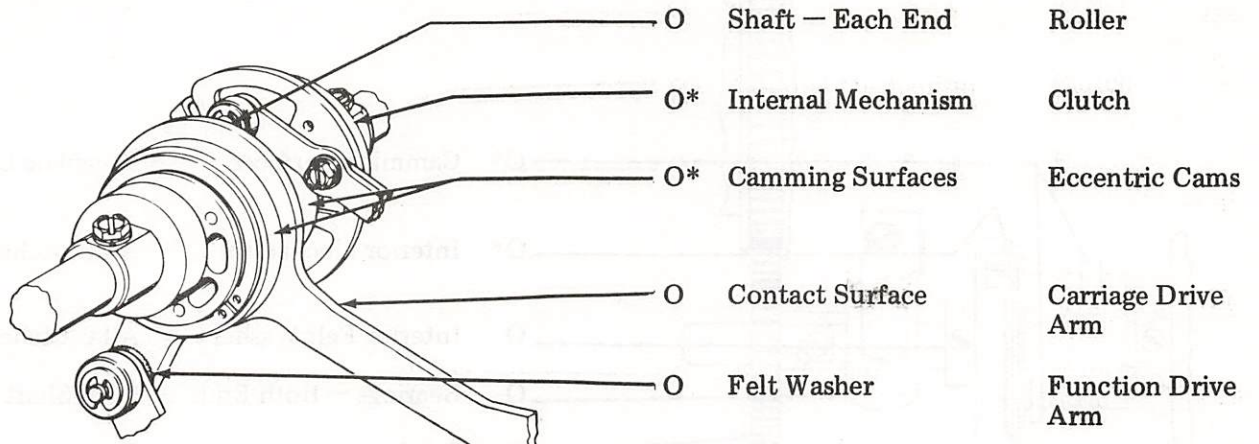

*Refer to 1.05.

left front view

2.03 Trip Shaft

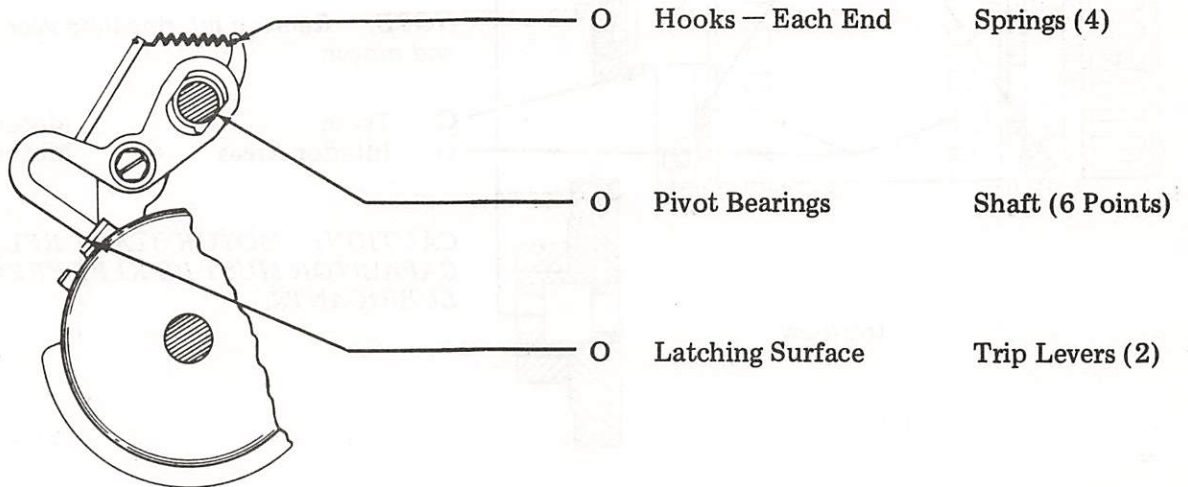

left side view

2.04 Codebar Clutch

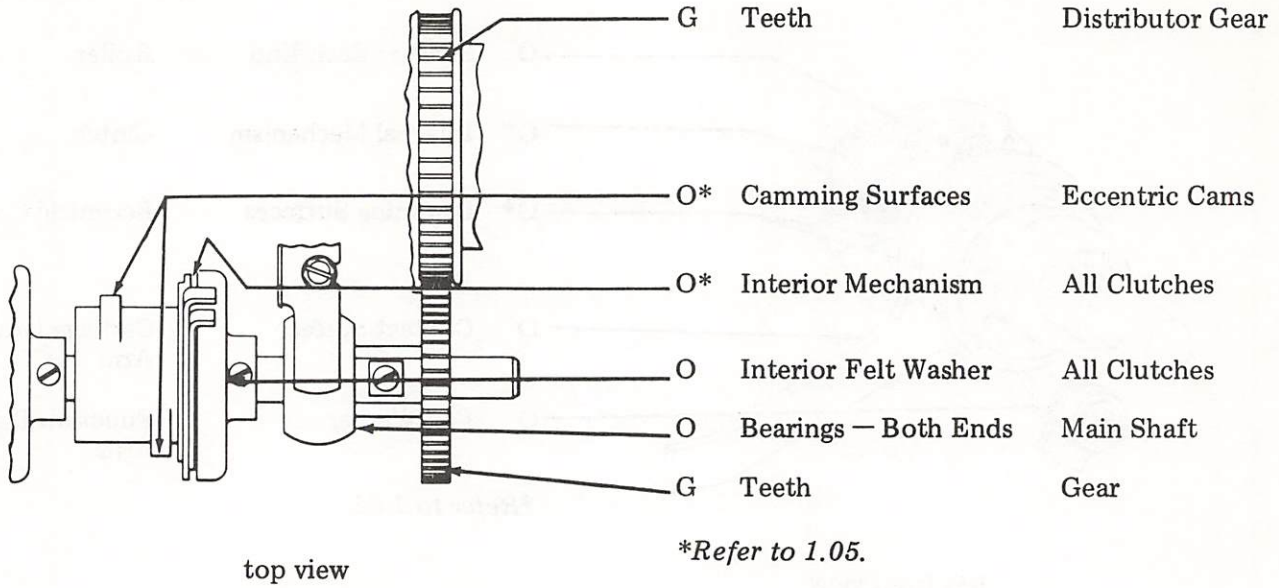

2.05 Motor Area

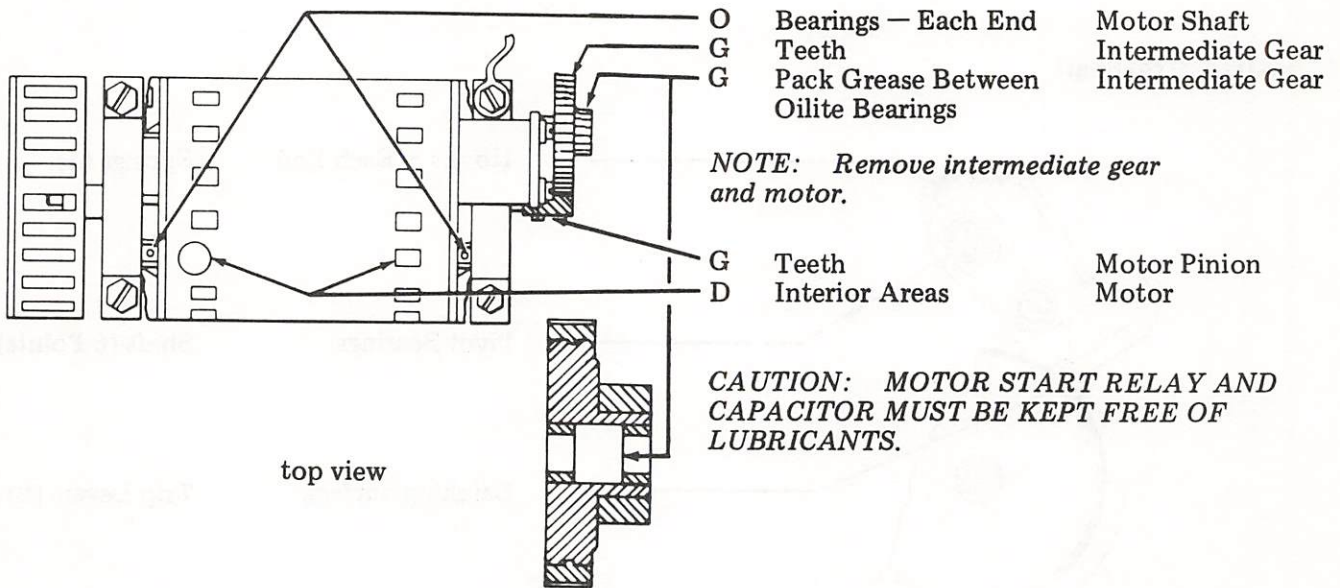

2.06 Intermediate Gears

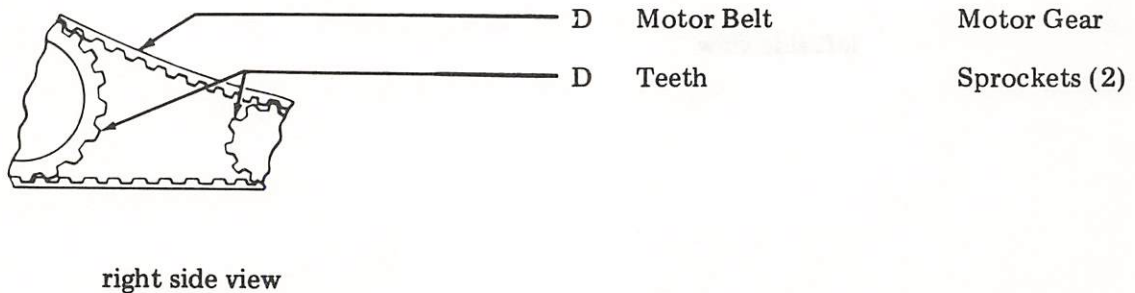

2.07 Function Shaft Area

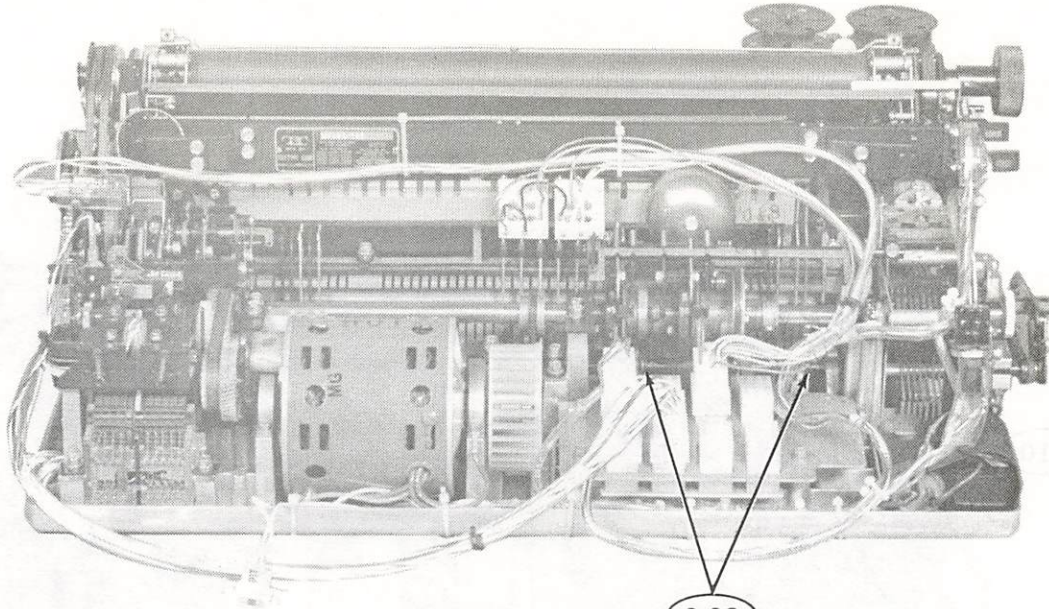

rear view

2.08 Function Rocker Shaft

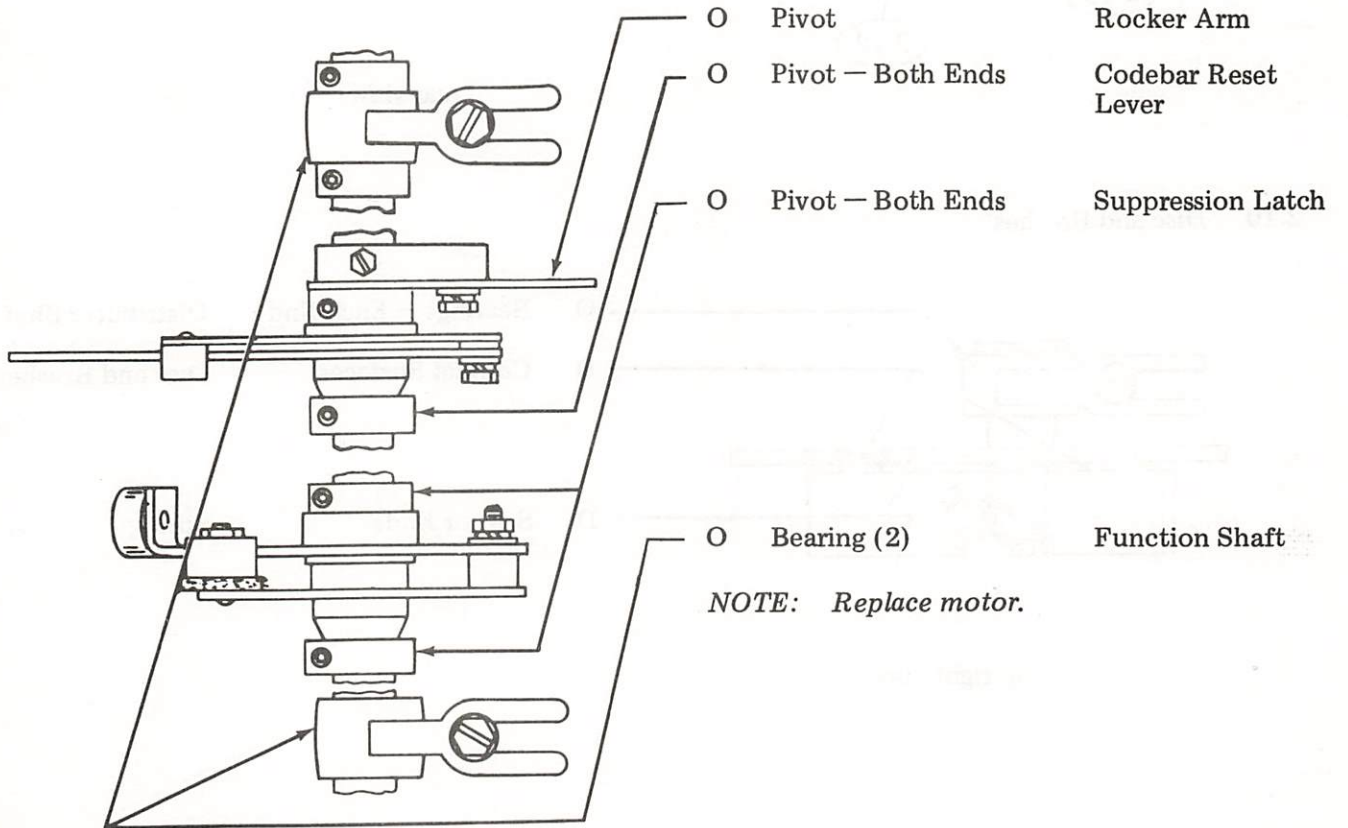

top right view

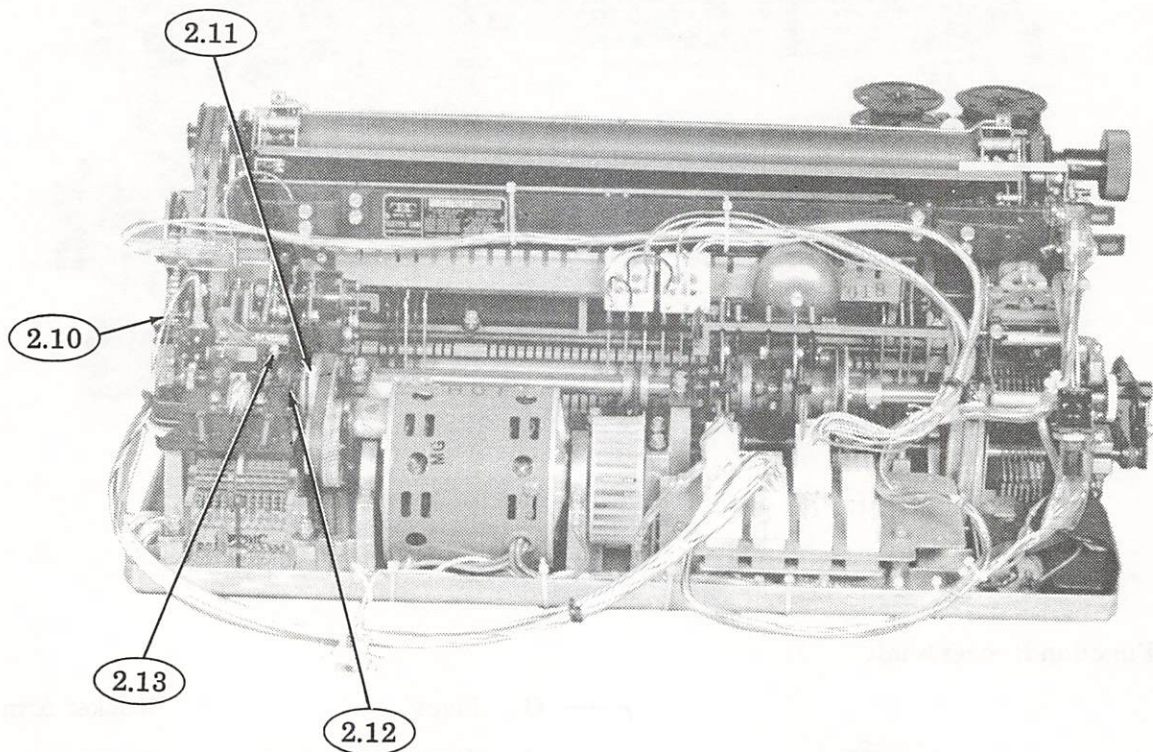

rear view

2.10 Disc and Brushes

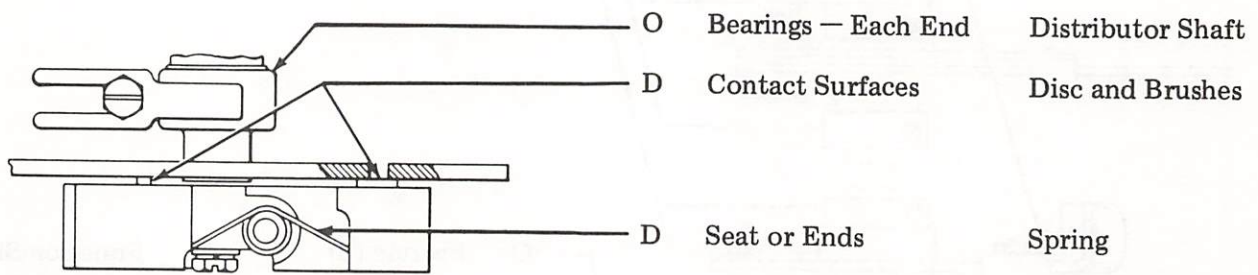

top right view

2.11 Stop Bail

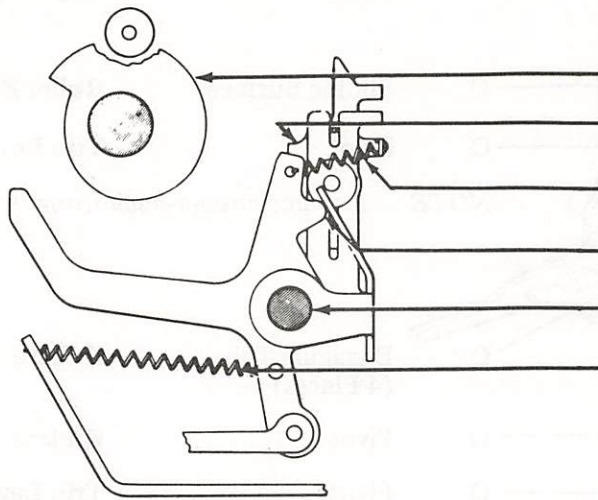

NOTE: Remove answer-back drum.

- O Camming Surface Distributor Clutch
- O Latching Surface Stop Bail
- O Hooks — Each End Stop Bail Spring
- O* Contact Surface Adjusting Tab
- O Pivots (2) Stop Bail
- O Hooks — Each End Follower Lever Spring

*Refer to 1.05.

right side view

2.12 Latchlever

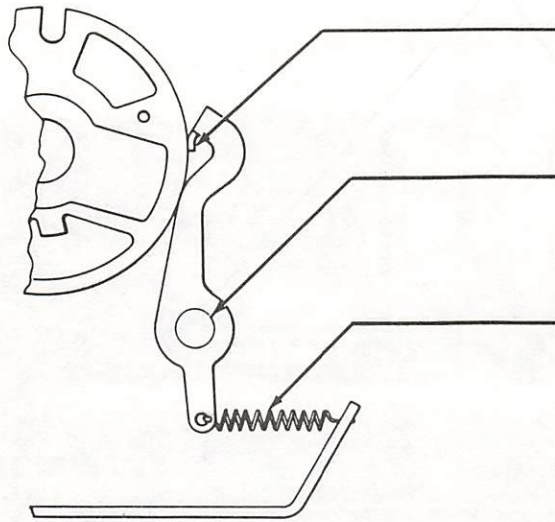

- O Latching Surface Latchlever
- O Pivot Trip Shaft
- O Hooks — Each End Spring

right side view

2.13 Trip Lever

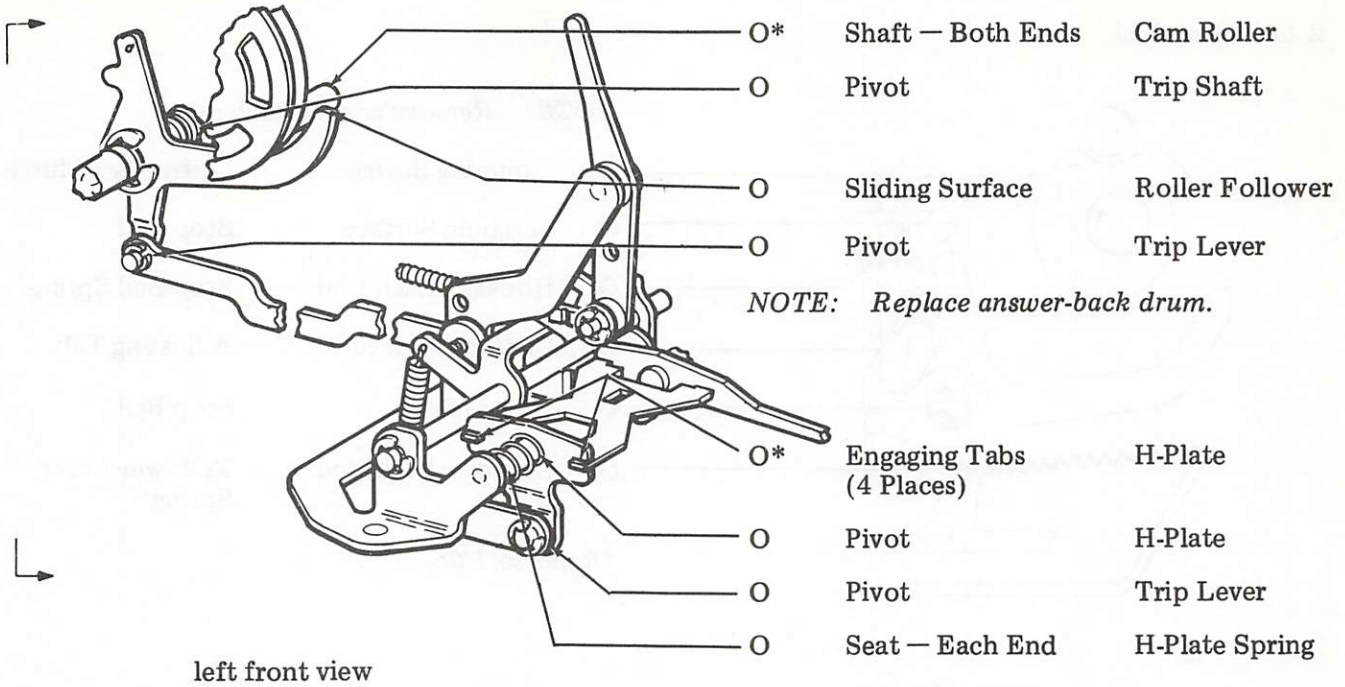

*Refer to 1.05.

2.14 Function Area

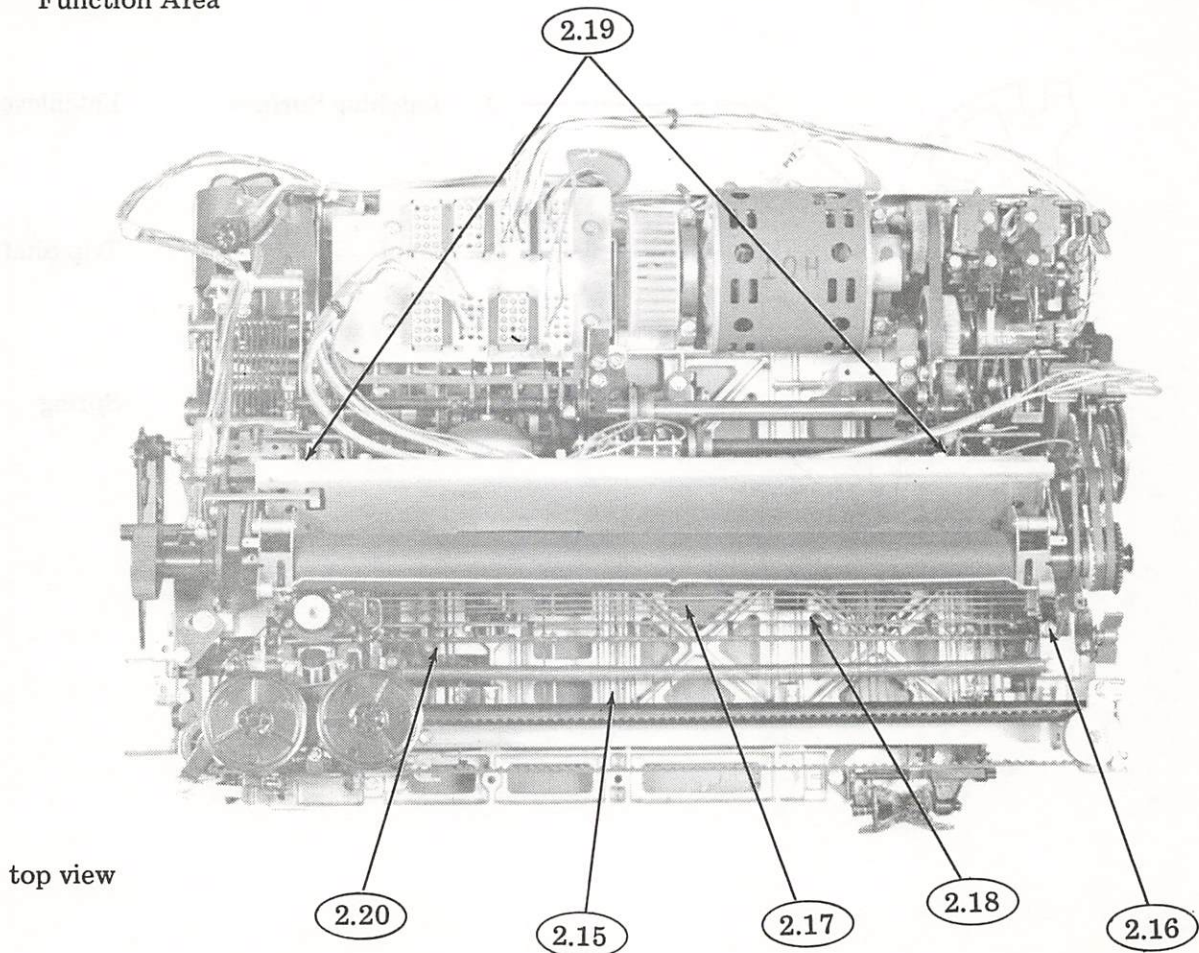

2.15 Function Levers

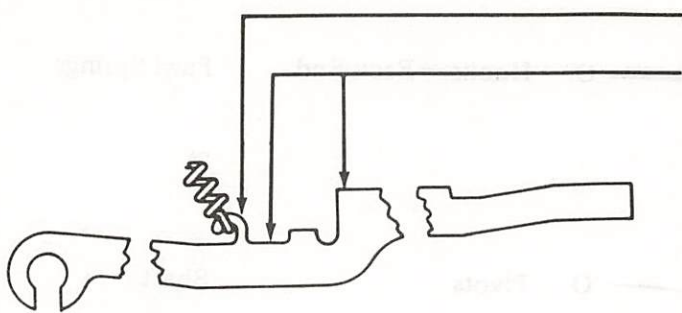

right side view

- O Hooks — Each End Springs
- O Engaging Surfaces Function Levers

2.16 Stripper Drive Lever

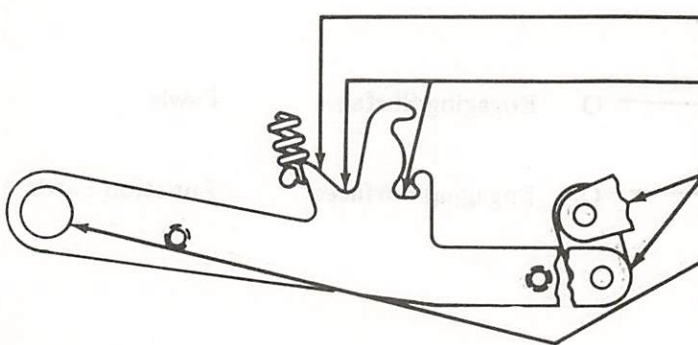

right side view

- O Hooks — Each End Springs
- O Engaging Surfaces Stripper Drive Lever
- O Pivots Stripper Drive Link
- O Felt Washers (2) (Each End of Shaft) Front Function Shaft

2.17 Codebars

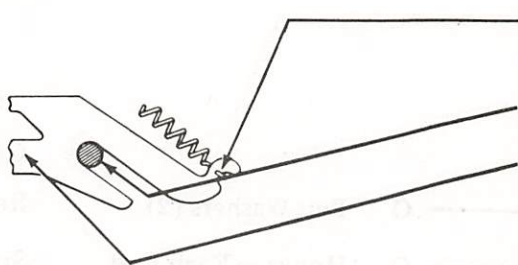

front view

- O Hooks — Each End Springs
- O* Pivots Codebar Shaft
- D Area Between Codebars

*Refer to 1.05.

2.18 Automatic Codebar

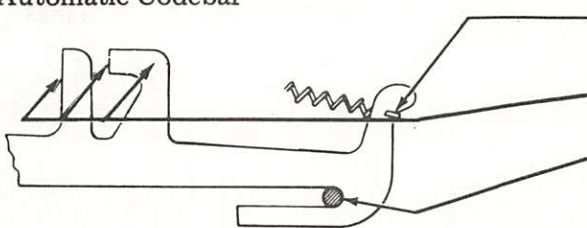

front view

- O Hooks — Each End Spring
- O Blocking Contact Tab (1 of 3)
- O* Pivot Codebar Shaft

*Refer to 1.05.

2.19 Rocker and Pawls

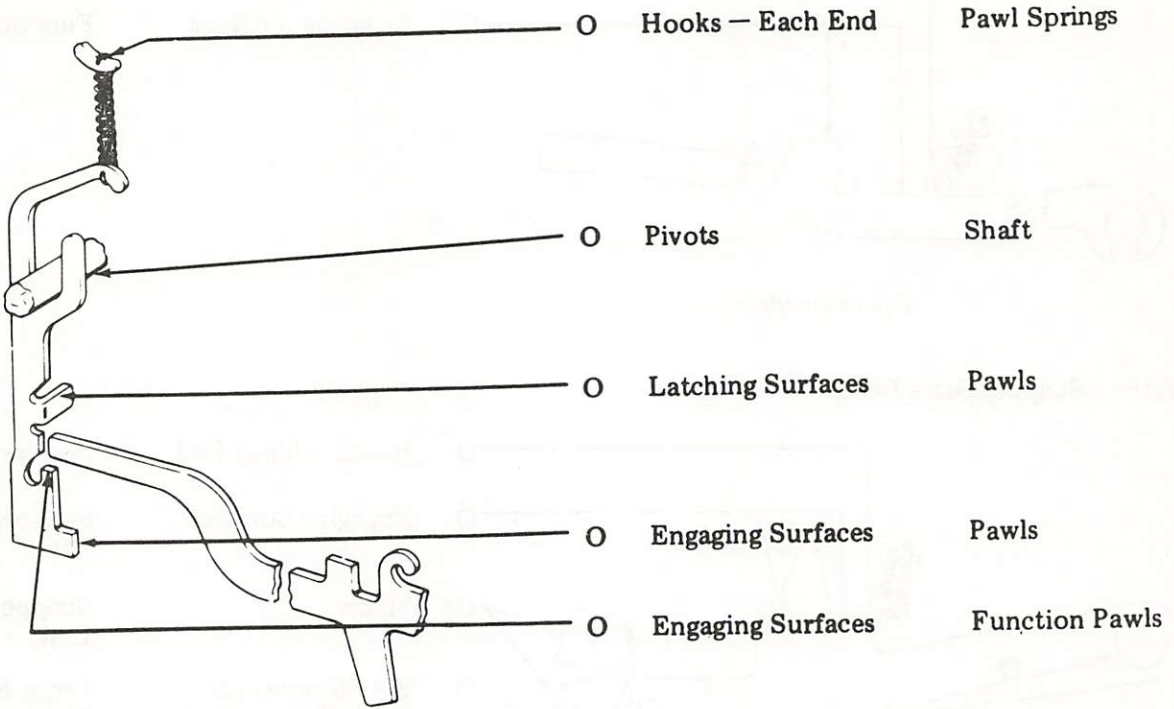

left front view

2.20 Reset Bail

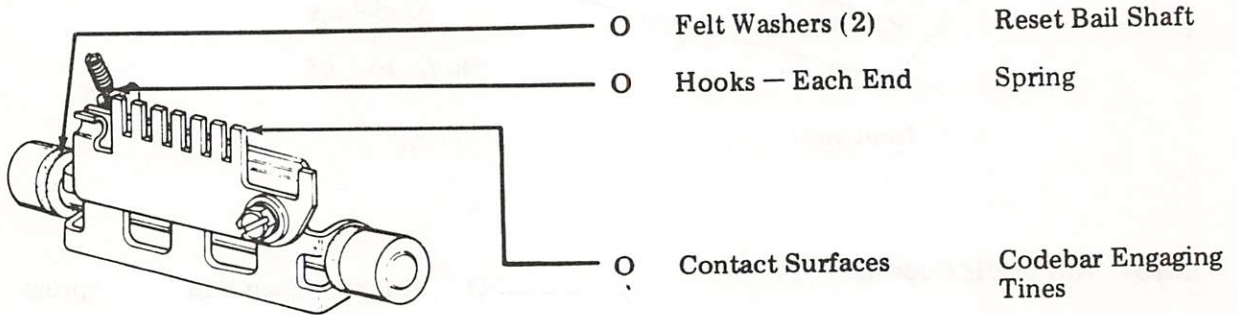

left front view

2.21 Spacing Area

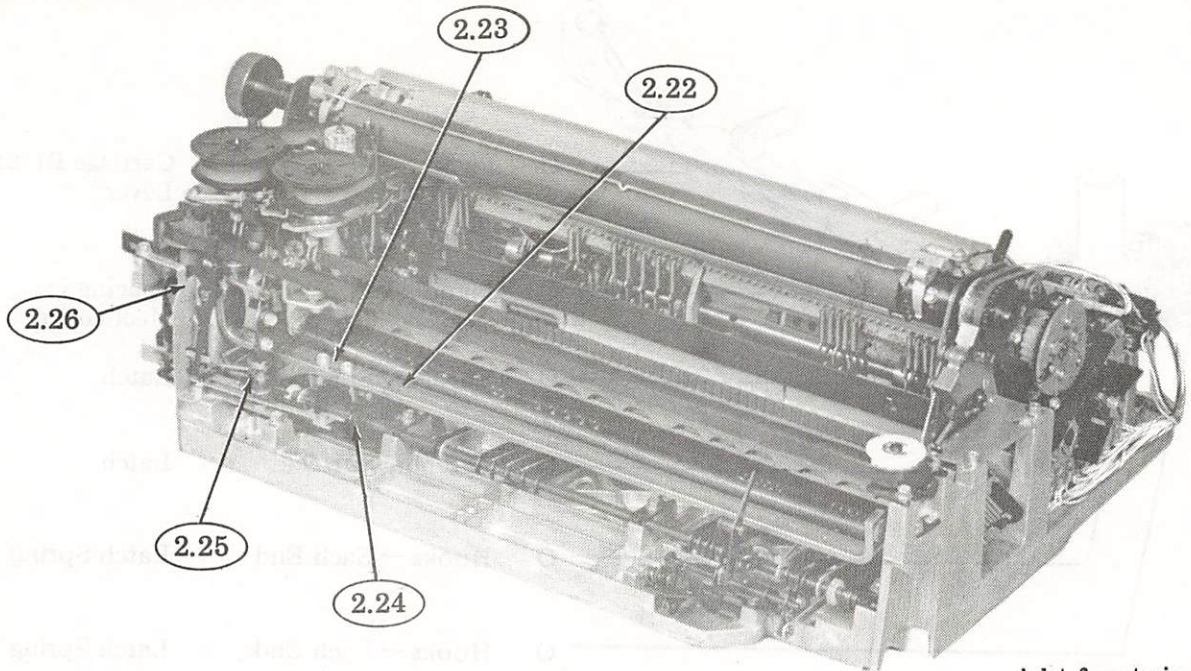

right front view

2.22 Space Bellcrank

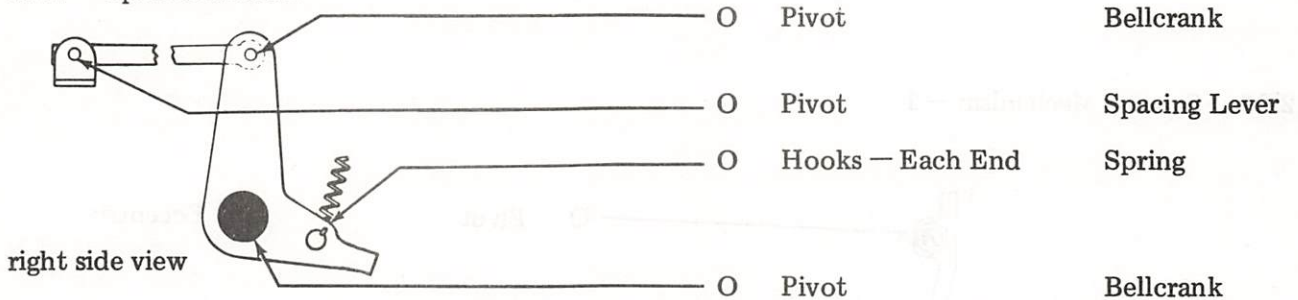

right side view

2.23 Drive Mechanism

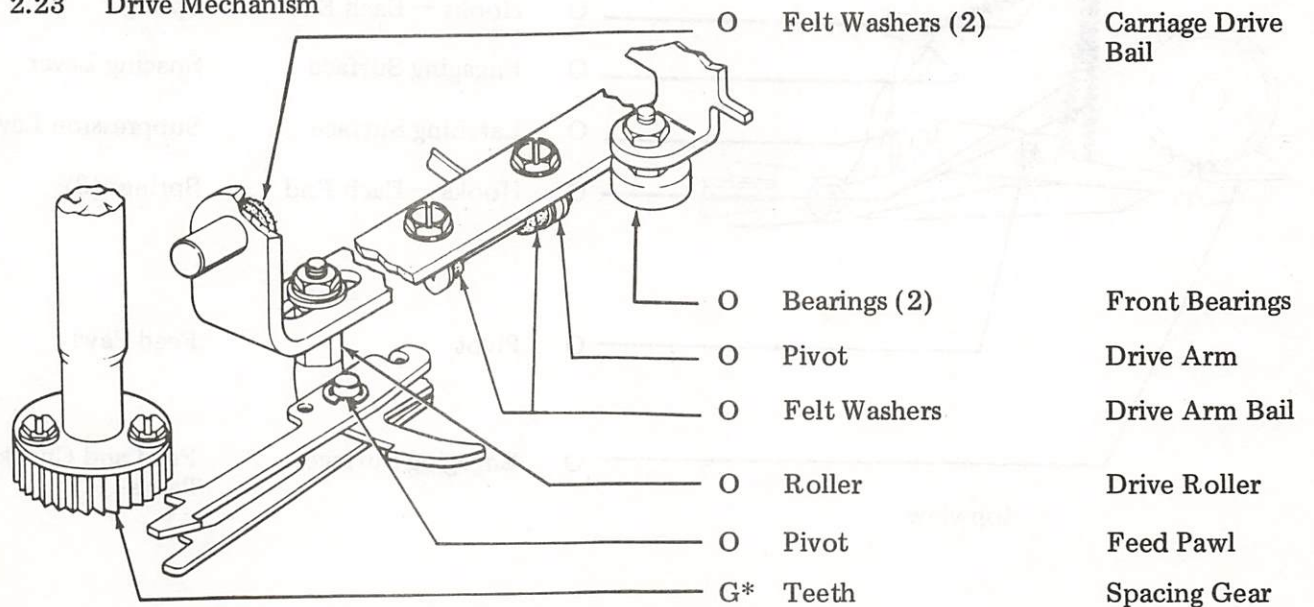

left front view

*Refer to 1.05.

2.24 Carriage Return and Spacing Levers

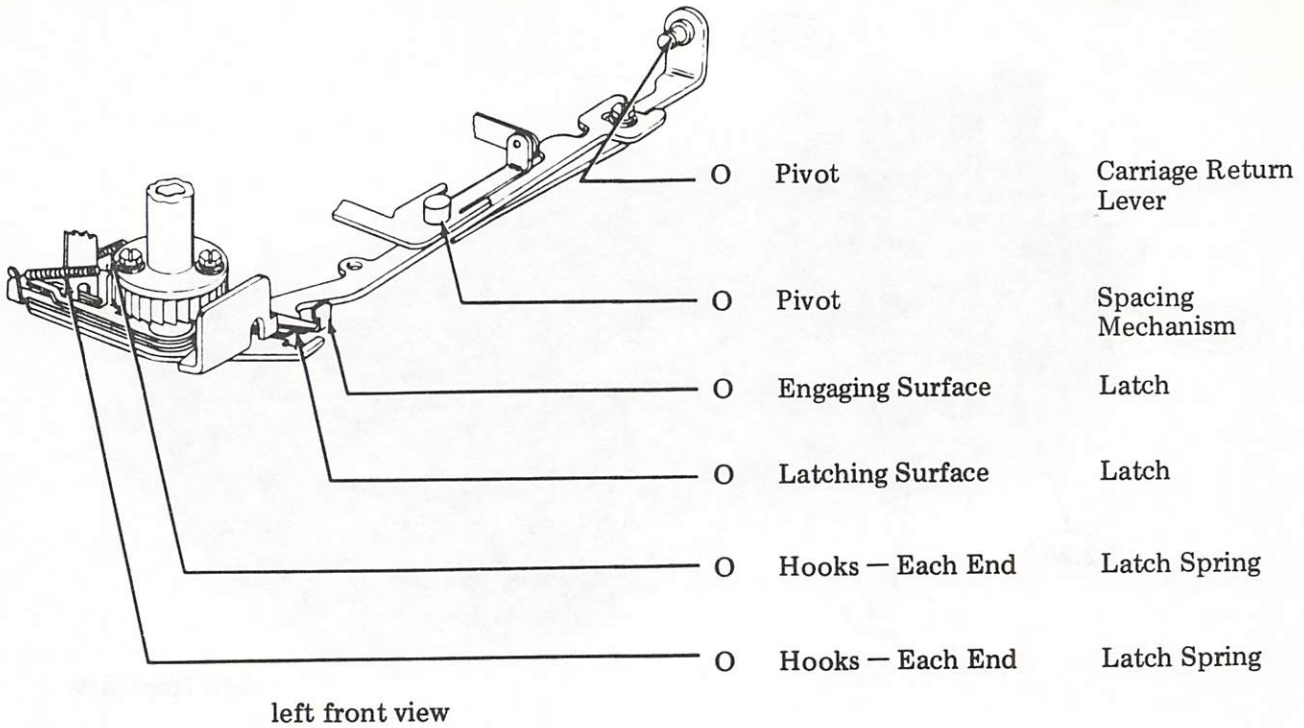

2.25 Spacing Mechanism — 1

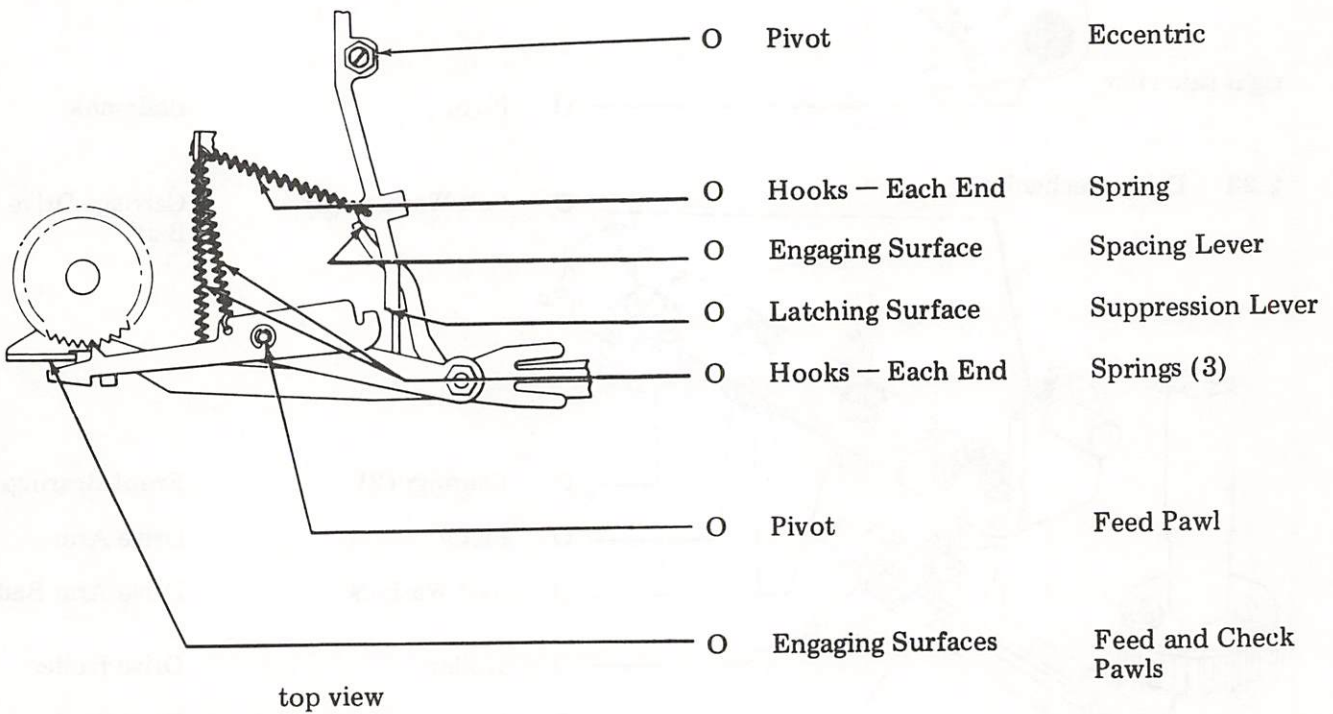

2.26 Spacing Mechanism — 2

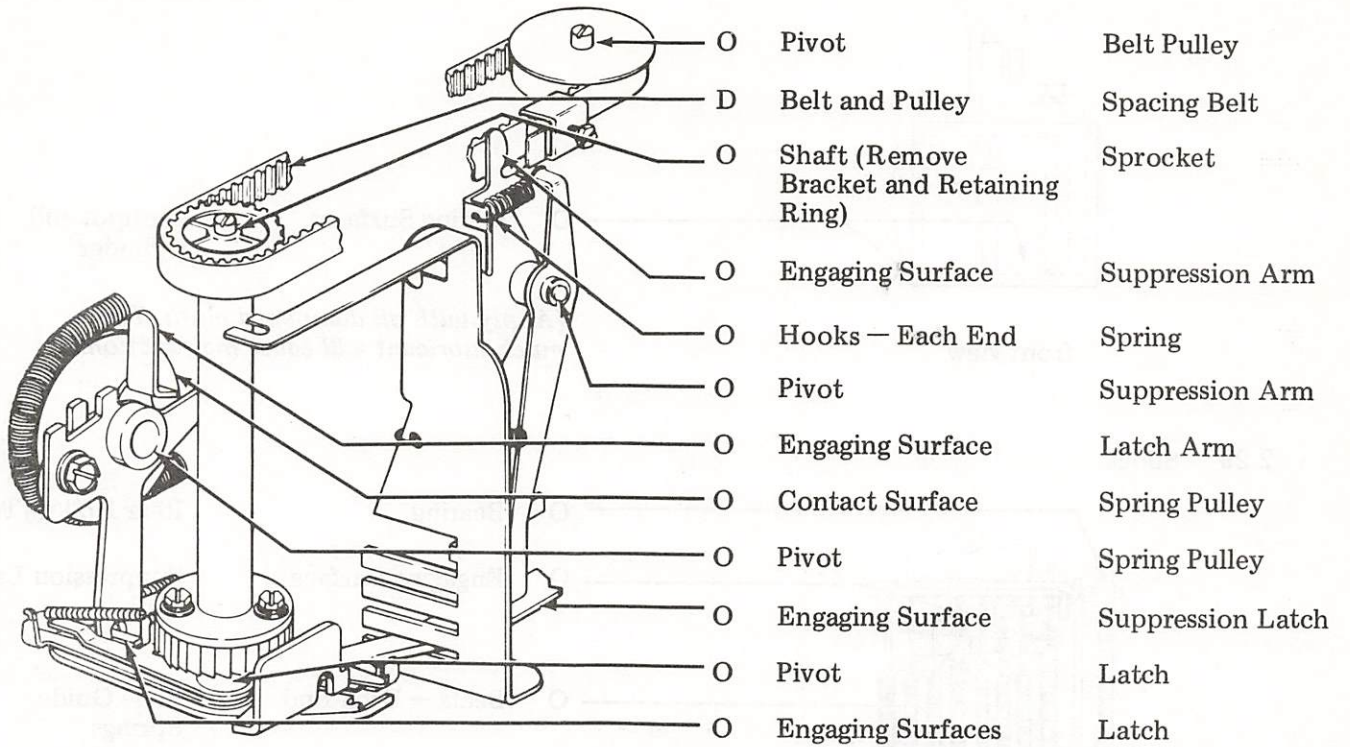

left front view

2.27 Carriage Area

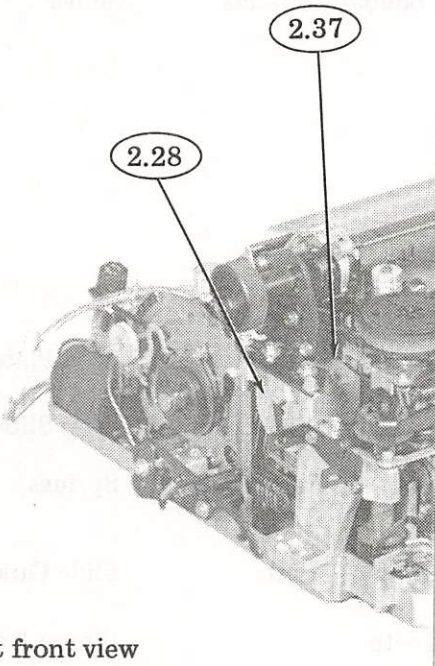

left front view

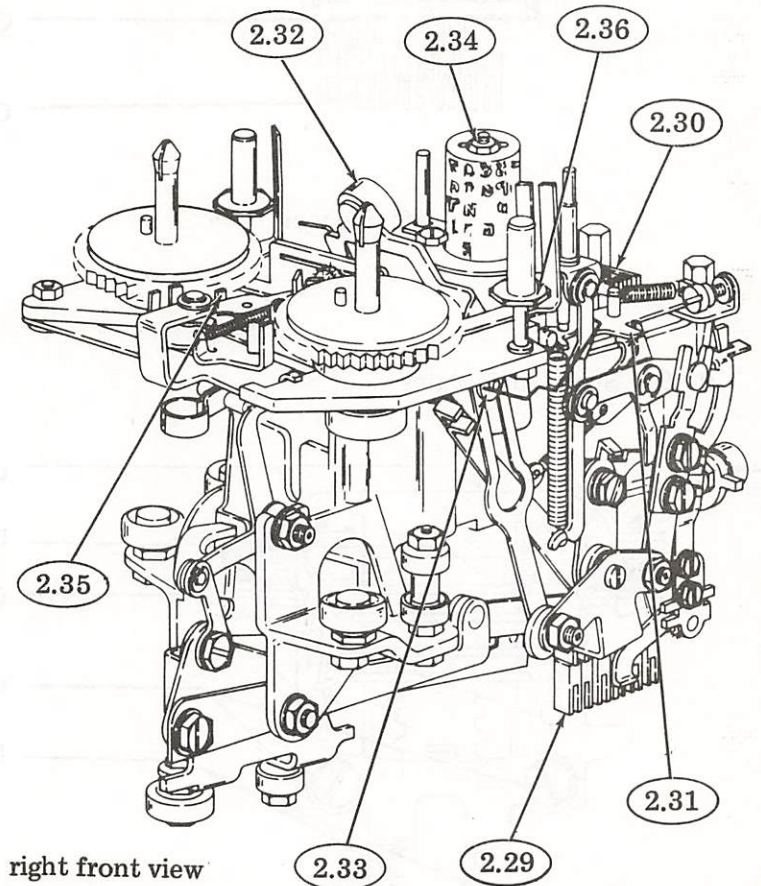

right front view

NOTE: Remove ribbon mechanism and carriage return spring before lubricating. For disassembly and reassembly, refer to Section 574-422-702TC.

2.28 Dashpot

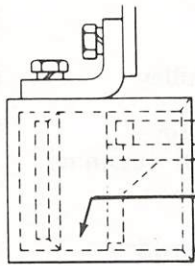

front view

O Sliding Surfaces Dashpot and Cylinder

(Apply with oil dampened cloth. Too much lubricant will cause malfunction.)

2.29 Slides

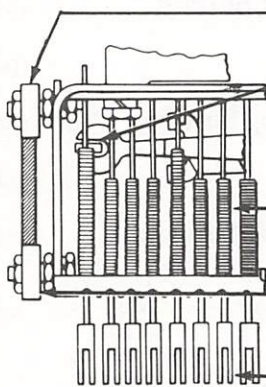

left side view

O Bearing Rear Roller (Top)
 O Engaging Surface Suppression Latch Fork
 O Seats - Each End Slide Guide Springs
 O Bearing Rear Roller (Bottom)
 O Codebar Contacts Slides

2.30 Slide Guideplates

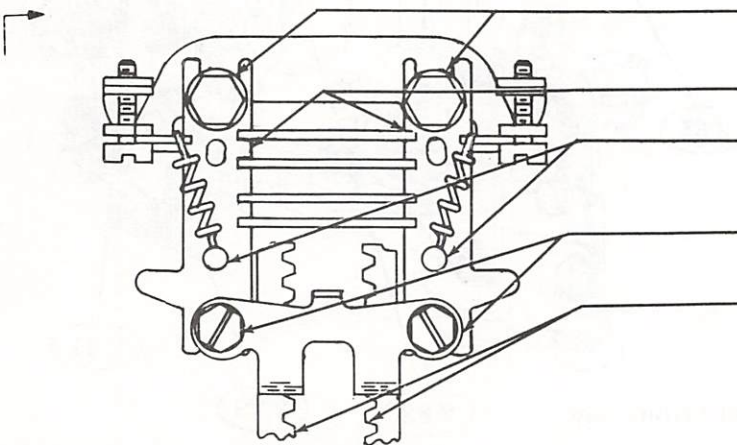

top view

O Sliding Contacts Stop Plate
 O Engaging Surfaces Stop Slides
 O Hooks - Each End Springs
 O Contact Points Slide Guides
 O Teeth Pinion Racks

2.31 Drive Arm

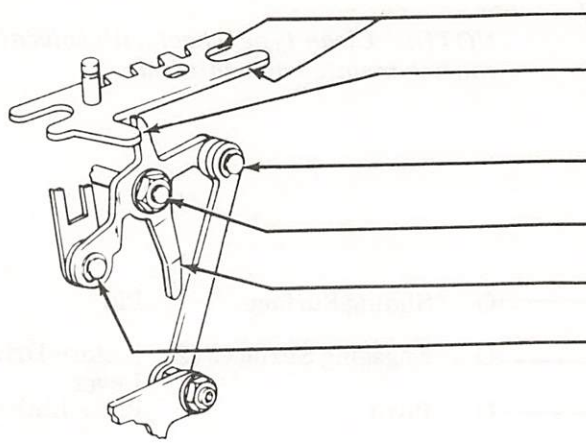

- O Contact Surface Plate
- O Contact Surfaces Plate and Drive Arm
- O Pivot Drive Arm
- O Pivot Drive Arm
- O Contact Surface Drive Arm
- O Pivot Link

right side view

2.32 Print Hammer

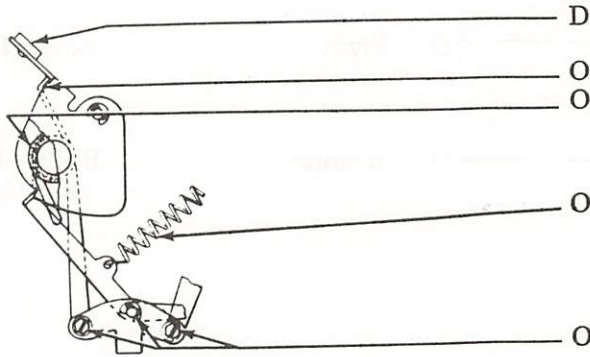

- D Surface Print Hammer
- O Ends (2) Torsion Spring
- O Pivots (2) Spring Shaft
- O Hooks — Each End Spring
- O Bearings (3) Drive Bail

right side view

2.33 Reset Arm

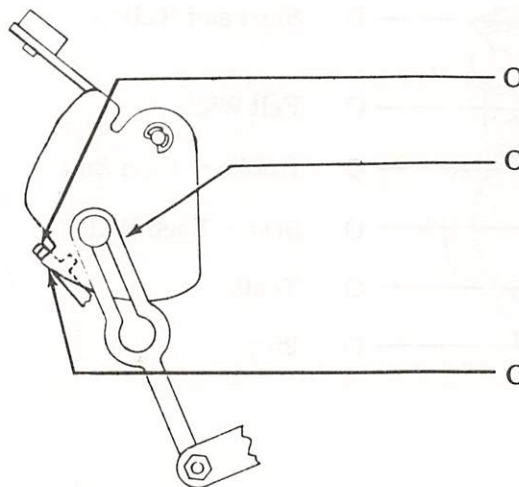

- O Latching Surface Trip Lever
- O Sliding Contacts Reset Arm
- O Camming Surface Print Hammer Bail

right side view

2.34 Type Wheel Mechanism

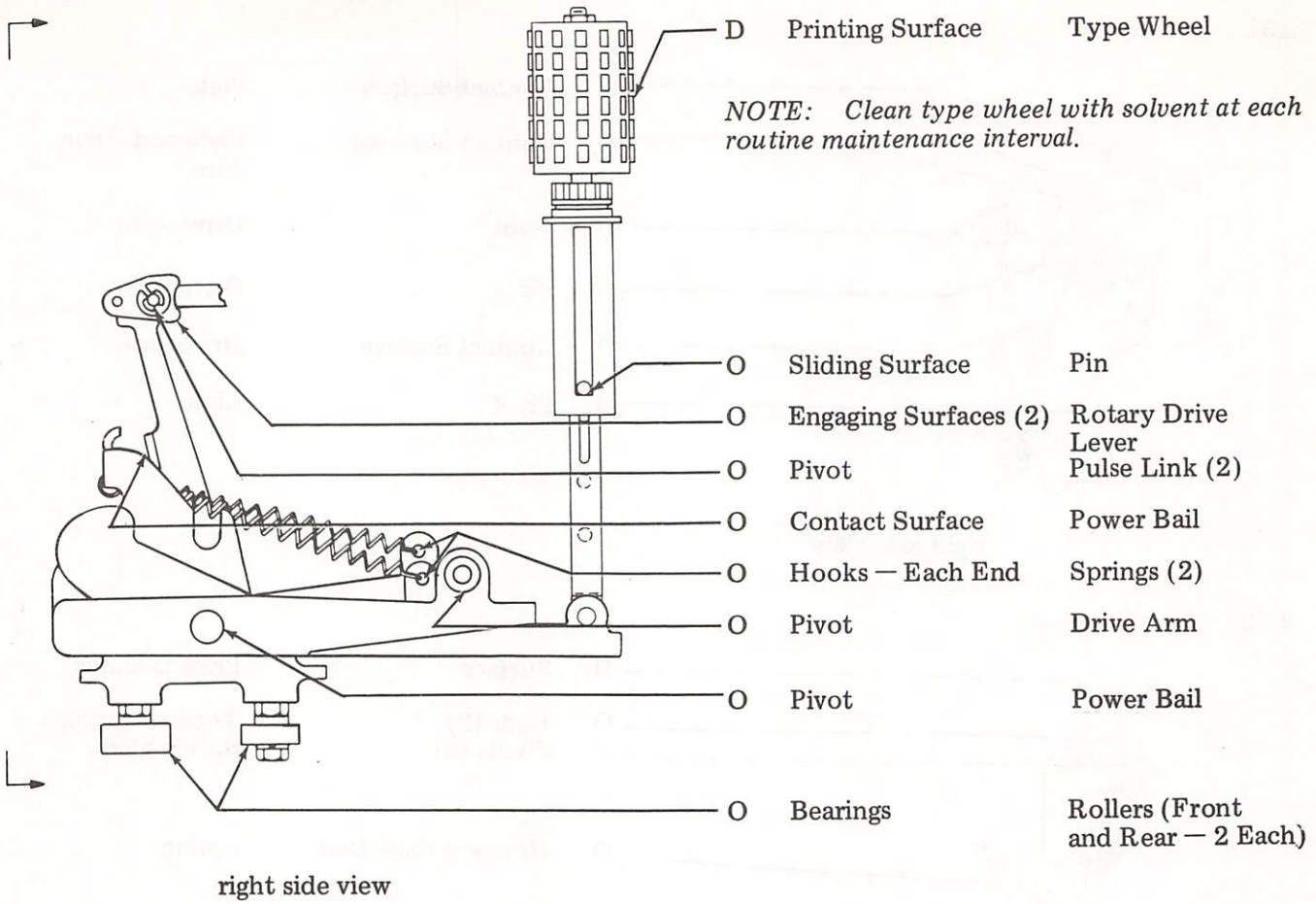

2.35 Ribbon Mechanism

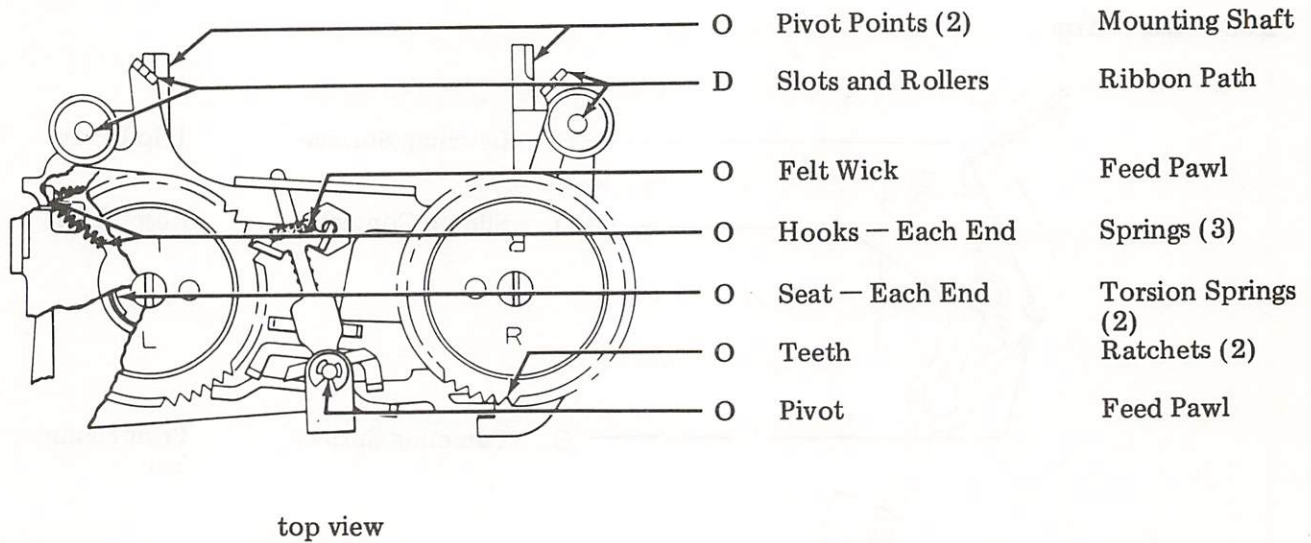

2.36 Ribbon Guide Spring

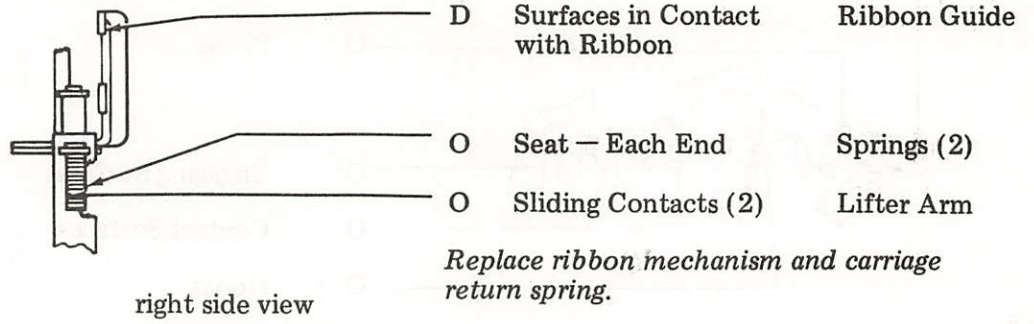

2.37 Carriage Rear Rail

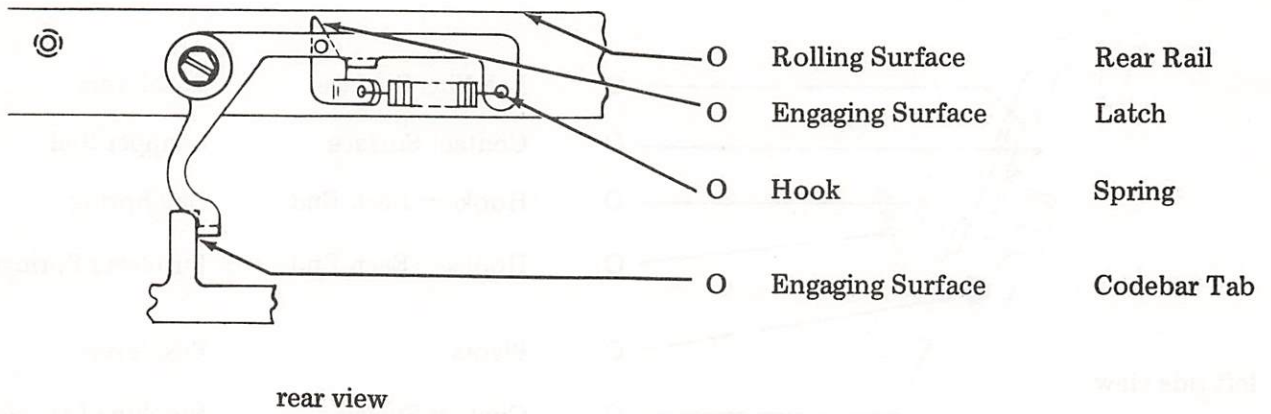

2.38 Selector Area

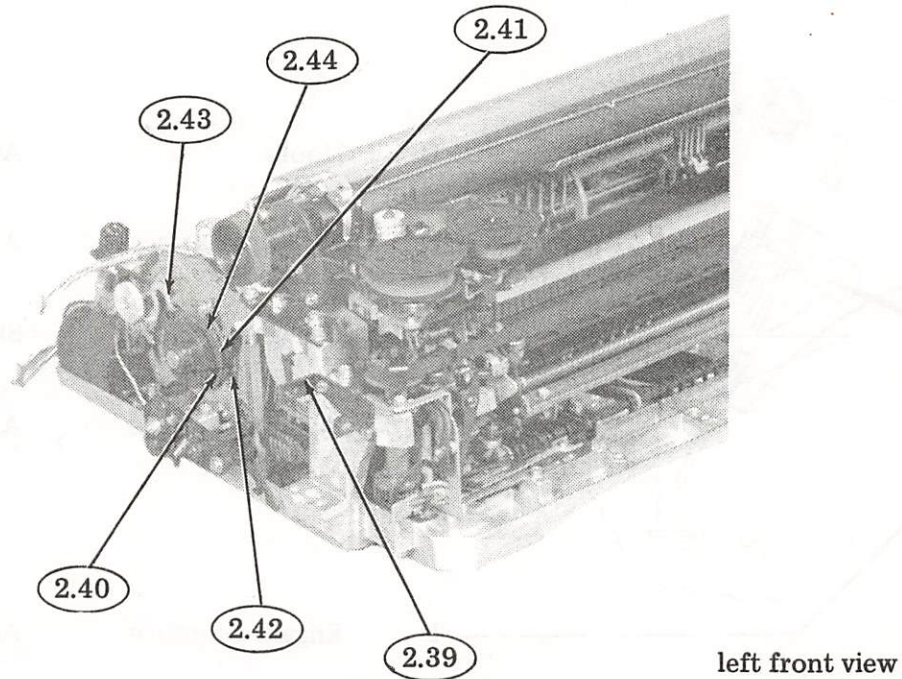

2.39 Blocking Levers

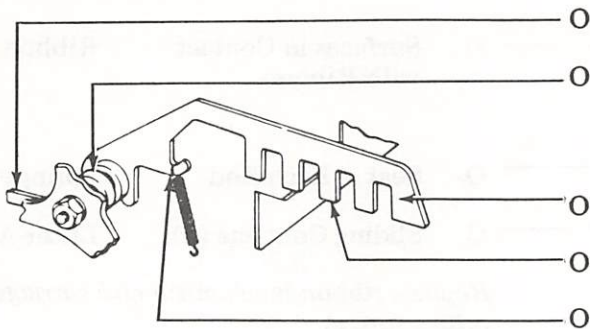

left front view

- | | | |
|---|-------------------|-----------------|
| O | Contact Surfaces | Blocking Levers |
| O | Pivots | Shaft |
| O | Engaging Surfaces | Codebar Slots |
| O | Contact Surfaces | Tines |
| O | Hooks | Springs |

2.40 Pushlevers and Stripper Bail

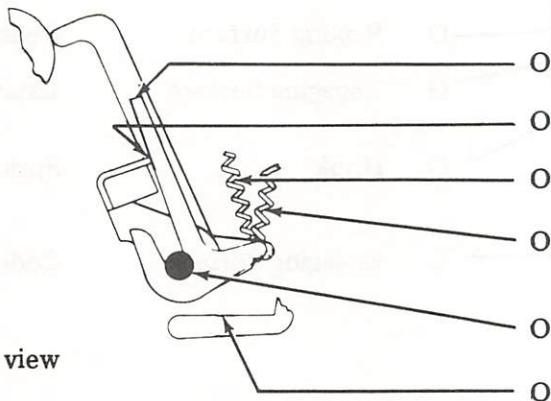

left side view

- | | | |
|---|------------------|-------------------|
| O | Latching Surface | Pushlevers |
| O | Contact Surface | Stripper Bail |
| O | Hooks — Each End | Bail Spring |
| O | Hooks — Each End | Pushlever Springs |
| O | Pivots | Pushlevers |
| O | Contact Surfaces | Blocking Levers |

2.41 Armature

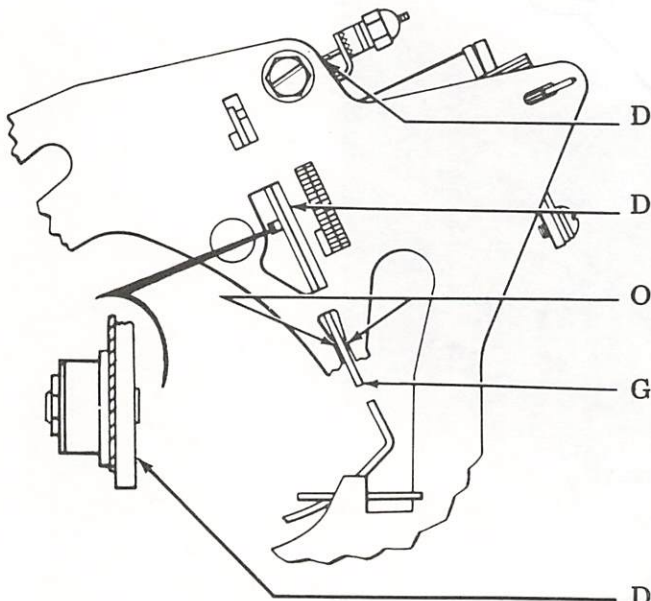

left side view

- | | | |
|---|-------------------|-----------------|
| D | Hooks | Armature Spring |
| D | Engaging Surfaces | Armature |
| O | Engaging Surfaces | Side Plates |
| G | Engaging Surface | Armature |
| D | Engaging Surface | Armature |

2.42 Selector Levers

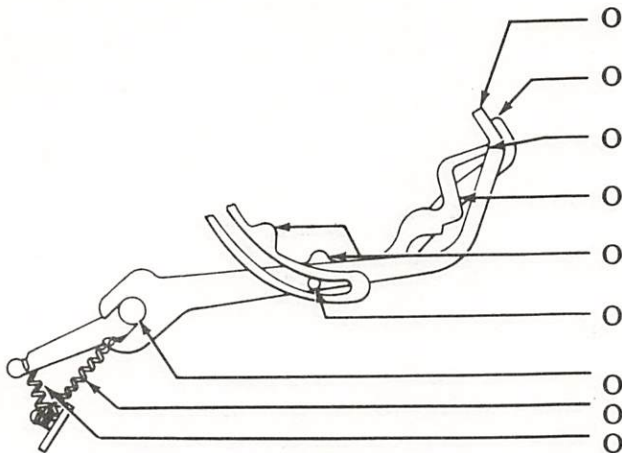

left side view

- | | |
|------------------|--------------------|
| Tip | Start Lever |
| Contact Surface | Locklever |
| Contact Surface | Selector Levers |
| Engaging Surface | Selector Levers |
| Camming Surface | Selector Levers |
| Sliding Contact | Start Lever |
| Pivots | Levers |
| Hooks — Each End | Start Lever Spring |
| Hooks — Each End | Spring (9) |

2.43 Latchlever and Trip Lever

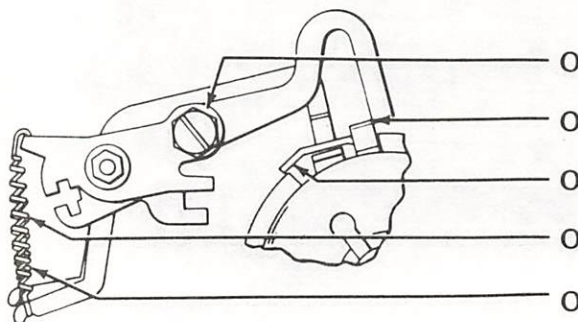

left side view

- | | |
|------------------|-------------------|
| Pivots (2) | Levers |
| Engaging Surface | Trip Lever |
| Latching Surface | Latchlever |
| Hooks — Each End | Trip Lever Spring |
| Hooks — Each End | Latchlever Spring |

2.44 Selector Clutch

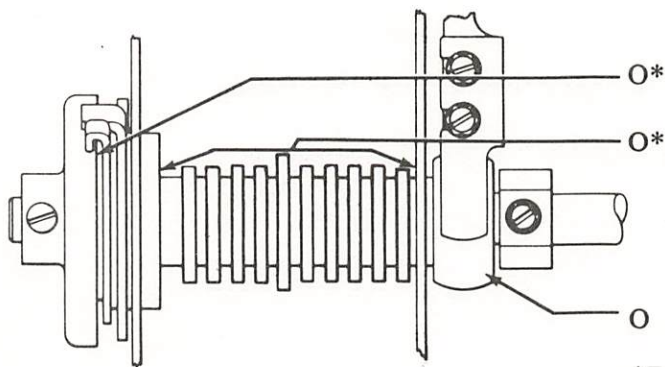

top view

- | | | |
|----|--------------------|-----------------|
| O* | Internal Mechanism | Selector Clutch |
| O* | Camming Surface | Selector Cam |
| O | Bearing — Each End | Main Shaft |

*Refer to 1.05.

SPROCKET FEED MECHANISMS

2.45 Paper Feed Area

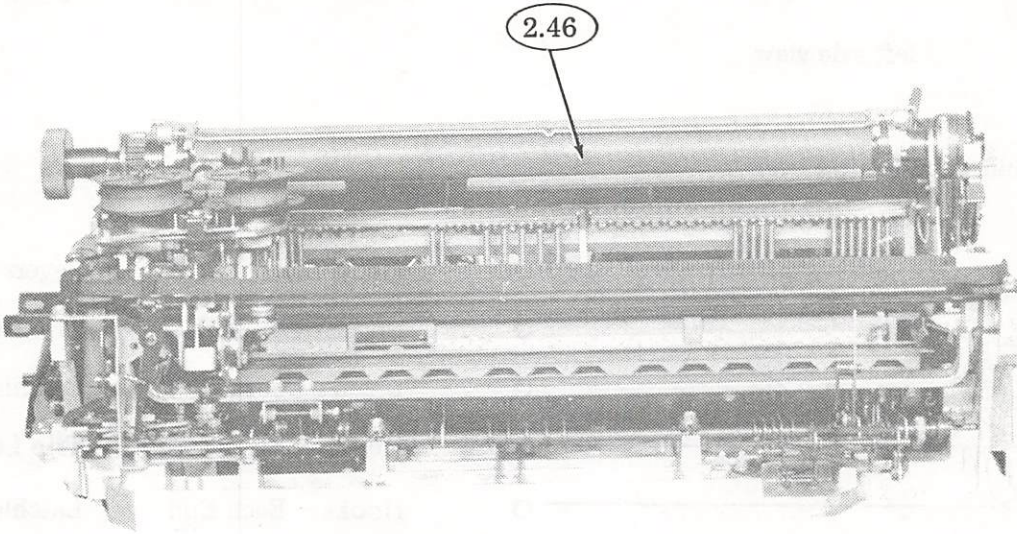

front view

2.46 Platen Mechanism

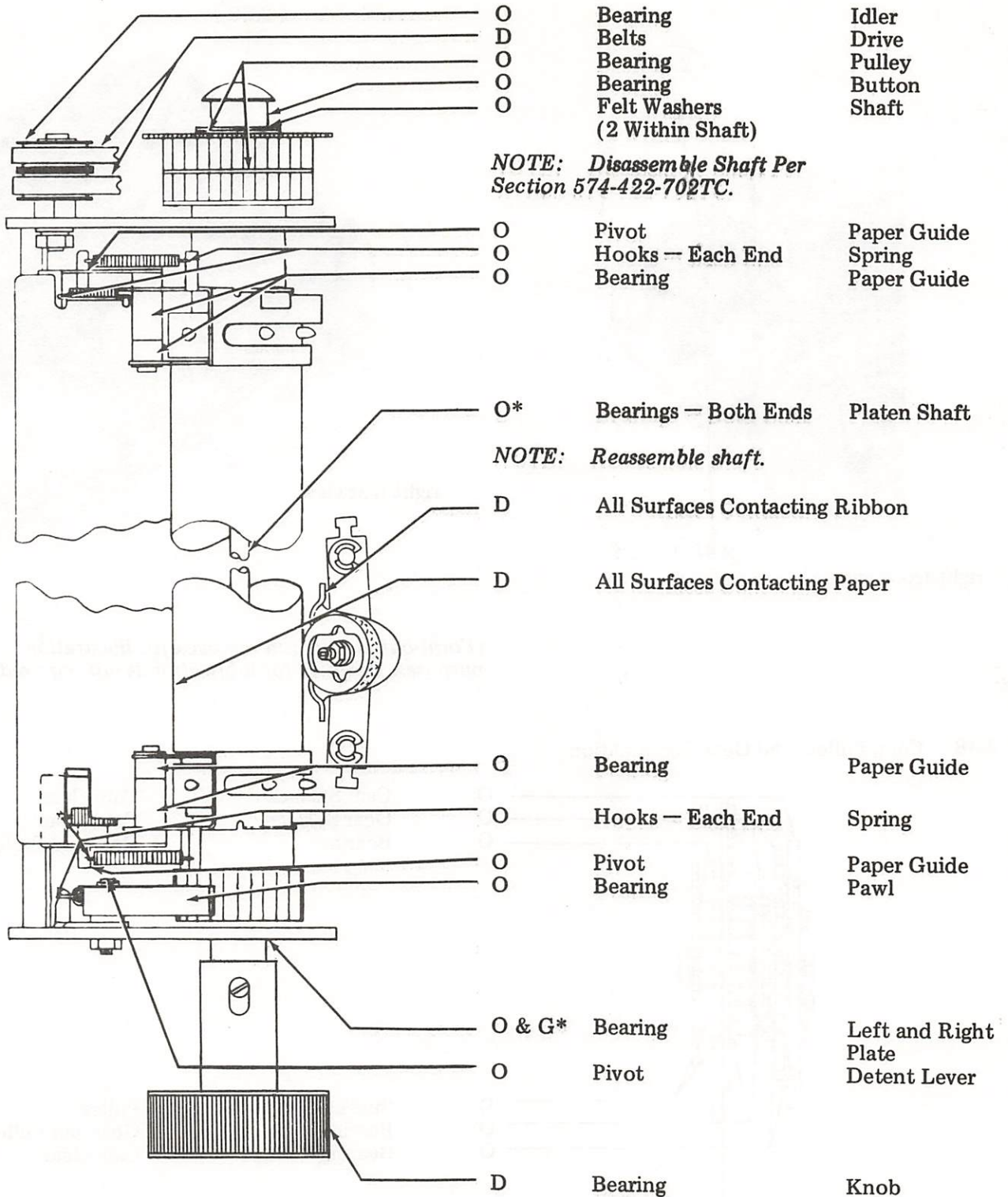

top view

2.47 Platen Drive Area

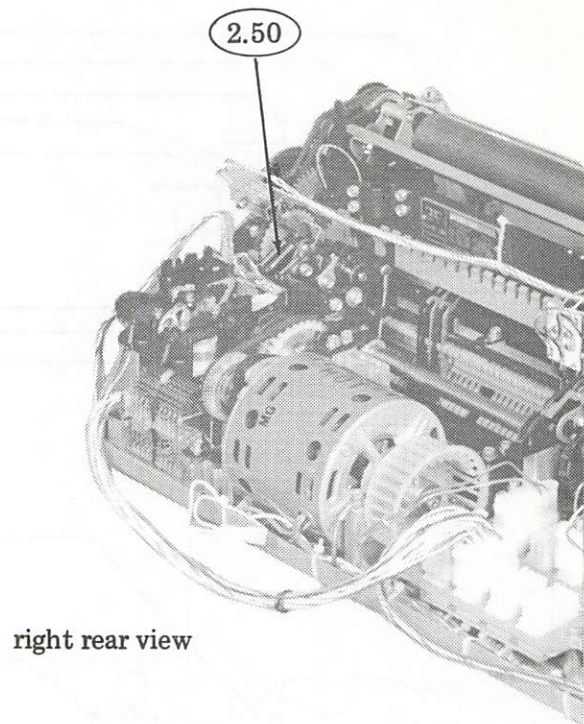
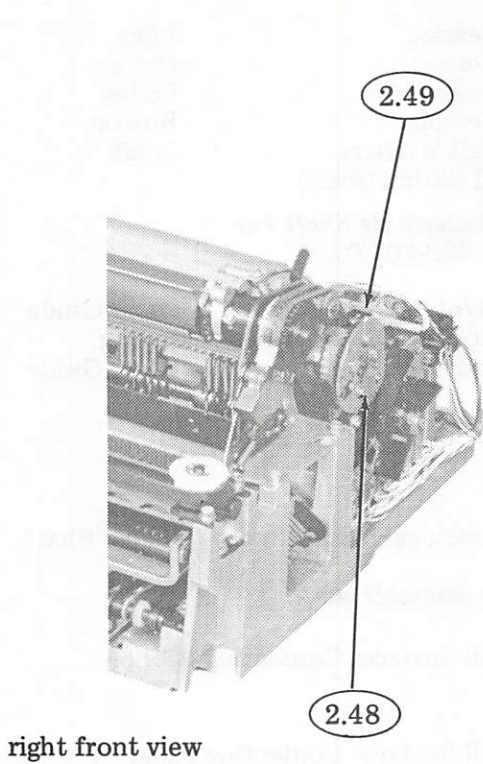

(Form-out mechanism removed for illustration purposes. Removal for lubrication is not required.)

2.48 Cam, Pulley, and Gear Combination

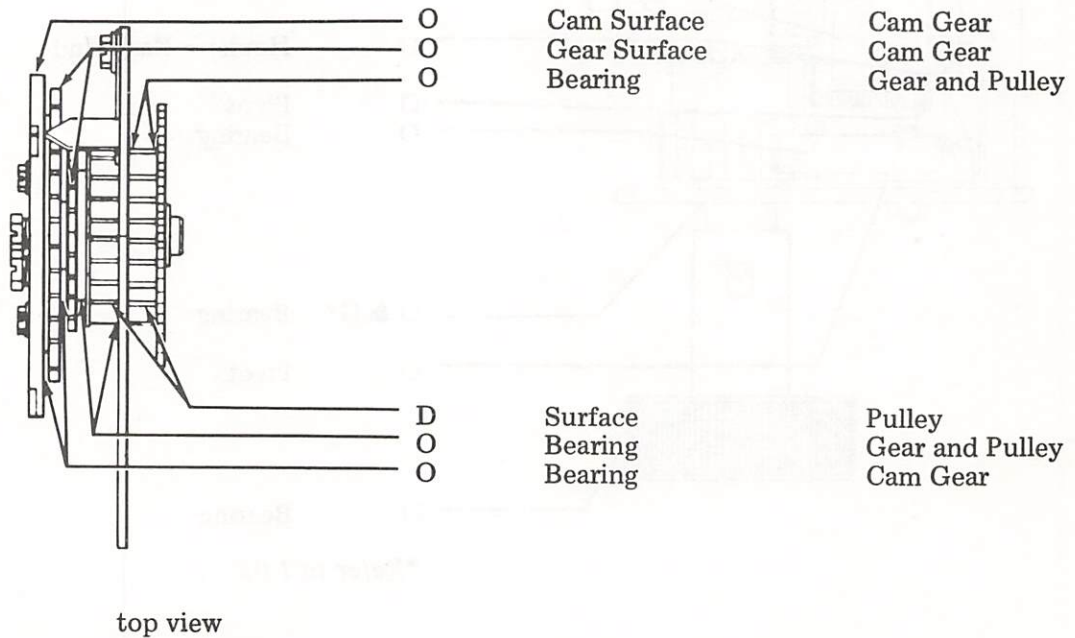

2.49 Form-Out Mechanism

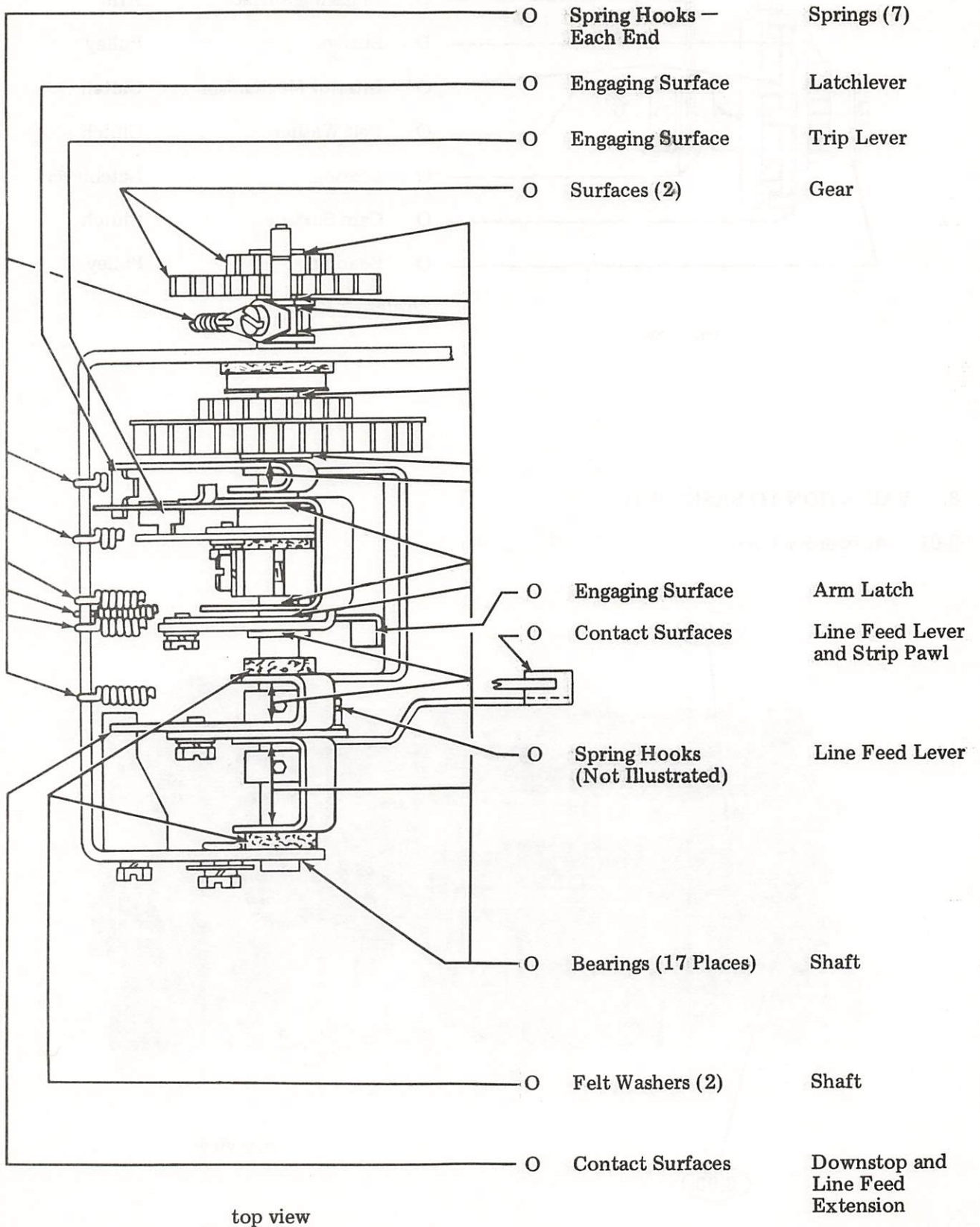

2.50 Line Feed Clutch

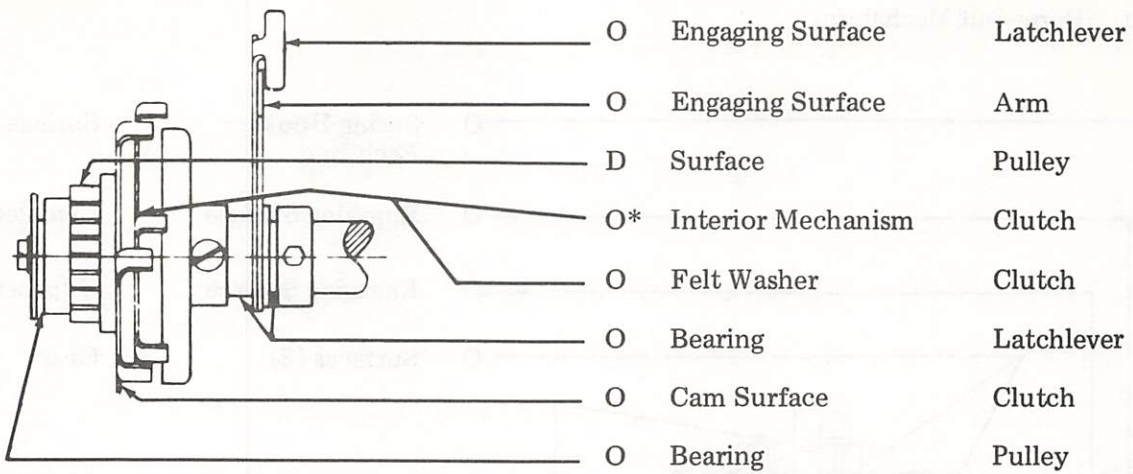

*Refer to 1.05.

top view

3. VARIATION TO BASIC UNIT

3.01 Answer-Back Area

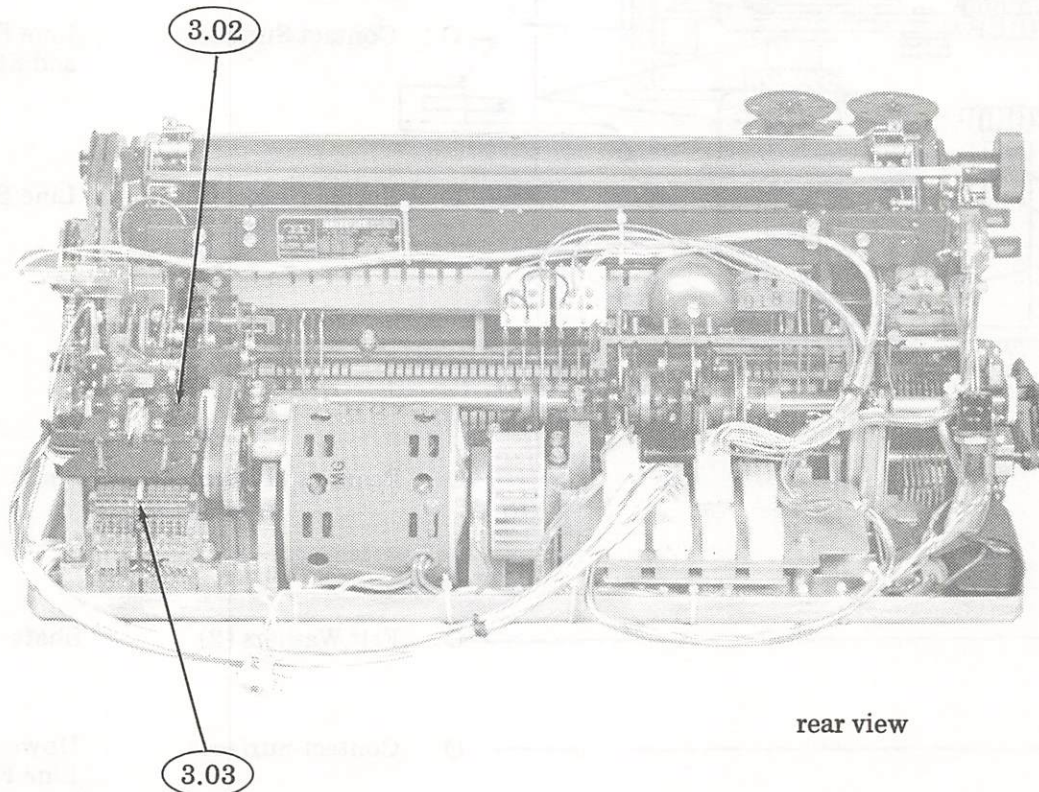

rear view

3.02 Trip Magnet

NOTE: Remove answer-back drum.

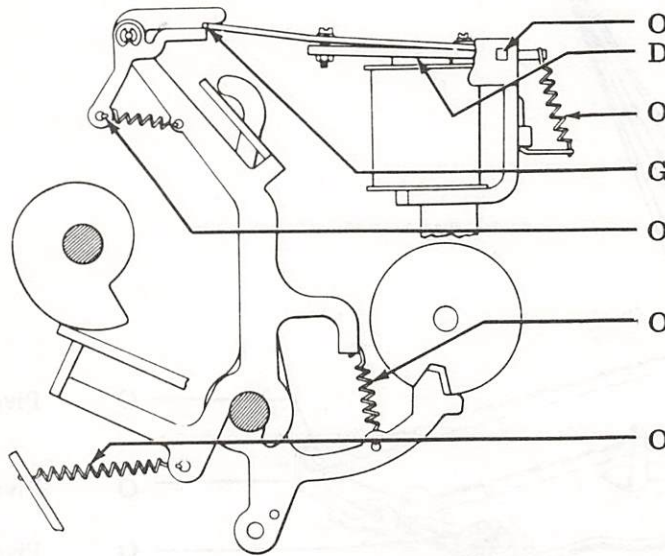

left side view

| | | |
|---|------------------|---------------------------------------|
| O | Pivots (2) | Armature |
| D | Contact Surface | Armature |
| O | Hooks — Each End | Armature Spring |
| G | Latching Surface | Armature Extension Lever Spring |
| O | Hooks — Each End | Lever Spring |
| O | Hooks — Each End | Control Lever Spring |
| O | Hooks — Each End | Blocking Follower Spring |

3.03 Answer-Back Mechanism

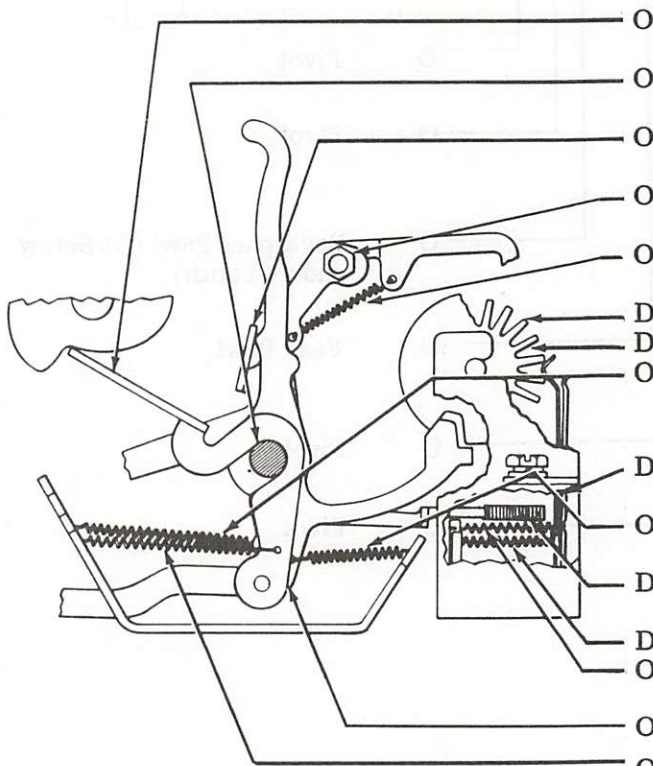

left side view

| | | |
|---|-------------------|-------------------------|
| O | Camming Surface | Follower Lever |
| O | Pivots (2) | Trip Shaft |
| O | Camming Surface | Feed Lever |
| O | Pivot | Feed Pawl |
| O | Hooks — Each End | Feed Pawl Spring |
| D | Tine Surfaces | Drum |
| D | Feed Ratchet | Drum |
| O | Hooks — Each End | Feed Lever Spring |
| D | Contact Surface | Contact Wires (9) |
| O | Hooks — Each End | Control Lever Spring |
| D | Contact Extension | Break Lever |
| D | Hooks | Springs (9) |
| O | Hooks — Each End | Detent Lever Spring |
| O | Pivot | Function Lever |
| O | Hooks — Each End | Follower Spring |

NOTE: Replace answer-back drum.

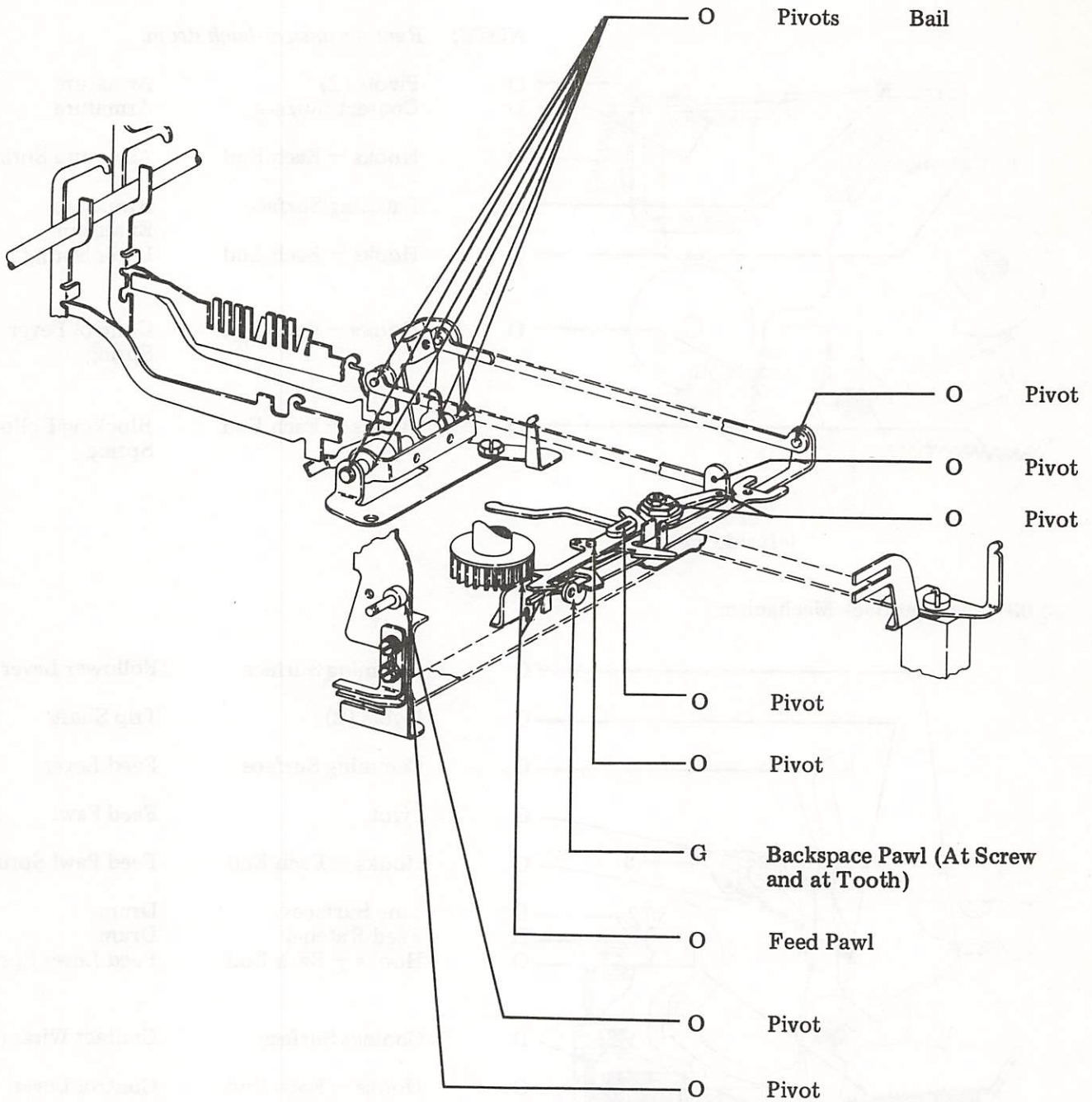

left front view

38 PRINTER
 DISASSEMBLY AND REASSEMBLY

| CONTENTS | PAGE | 2. PRINTER |
|------------------------------------------------------------------------------------------------------------------------------------------------------------------------------------------------------------------------------------------------|------|------------------------------------------------------------------------------------------------------------------|
| 1. GENERAL | 1 | CARRIAGE MECHANISM |
| 2. PRINTER | 1 | 2.01 Disassemble carriage mechanism (Figure 1) as follows: |
| CARRIAGE MECHANISM | 1 | (a) Unhook carriage return spring from carriage. |
| PLATEN MECHANISM | 1 | (b) Loosen two screws in spacing pulley mounting bracket. |
| SELECTOR MECHANISM | 3 | (c) Loosen two screws in spacing drum mounting bracket. |
| CODEBAR MECHANISM | 3 | (d) Rotate mounting brackets attached to casting and remove. |
| FUNCTION BOX MECHANISM | 4 | (e) Disengage spacing belt from pulley on spacing drum. |
| TRIP SHAFT MECHANISM | 4 | (f) Slide front carriage shaft to the right and remove. |
| MOTOR | 5 | (g) Disengage slide guides from codebars by lifting and rotating front of carriage to the left. Remove carriage. |
| FORM-OUT MECHANISM | 5 | 2.02 Reassemble carriage mechanism by reversing procedures in 2.01. |
| MAIN SHAFT MECHANISM | 6 | |
| DISTRIBUTOR MECHANISM | 6 | PLATEN MECHANISM |
| FUNCTION ROCKER SHAFT | 7 | 2.03 Disassemble platen mechanism (Figure 1) as follows: |
| 1. GENERAL | | (a) Loosen nut on idler pulley post and back off on the pulleys. |
| 1.01 This section provides disassembly and reassembly instructions for the 38 Printer. These instructions are confined to major subassemblies only. If further printer disassembly and reassembly is required, refer to Section 574-422-800TC. | | (b) Slip off belts from platen sprockets. |
| | | (c) Loosen four mounting screws from platen side plates. |
| | | (d) Lift platen mechanism from printer. |
| 1.02 To remove the printer as a unit from the teletypewriter, refer to Section 574-400-702TC. | | 2.04 Reassemble carriage mechanism by reversing procedure in 2.03. |

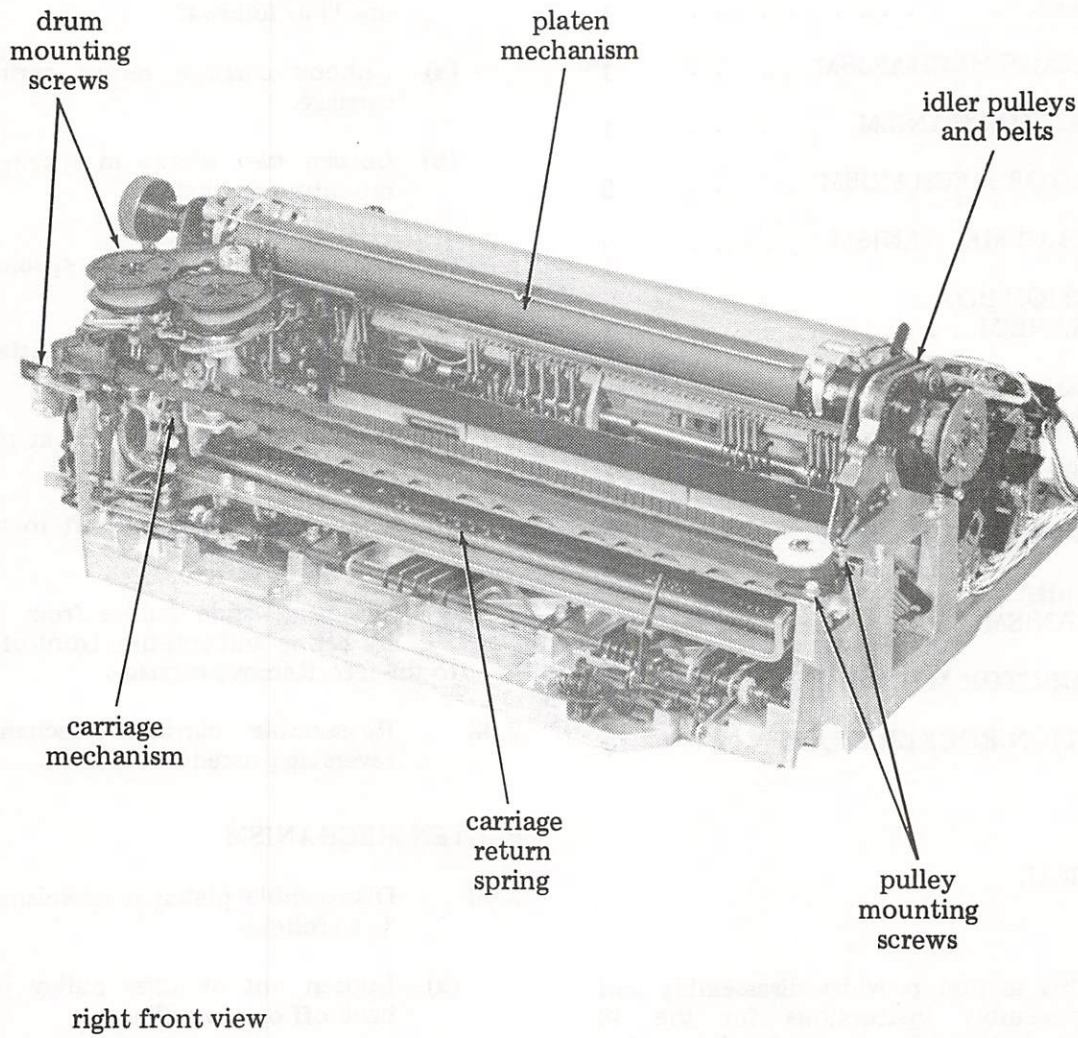

Figure 1 - Carriage and Platen Mechanisms

SELECTOR MECHANISM

- 2.05 Disassemble selector mechanism (Figure 2) as follows:
- (a) Install selector cam removal tool per instructions on label.
 - (b) Remove mounting screw from selector clutch.
 - (c) Remove selector clutch by sliding and rotating it to the left.
 - (d) Remove platen mounting post and codebar clutch trip arm.
 - (e) Remove blocking lever upstop bracket.
 - (f) Remove selector magnet leads and three selector mounting screws.
 - (g) Lift blocking levers from guide slots and remove selector mechanism.
- 2.06 Reassemble selector mechanism by reversing procedure in 2.05.

CODEBAR MECHANISM

- 2.07 Disassemble codebar mechanism (Figure 2) as follows:
- (a) Disassemble carriage mechanism as outlined in 2.01.
 - (b) Loosen upstop mounting bracket screw and remove bracket.
 - (c) Tighten upstop mounting bracket screw to secure retaining plate to printer casting.
 - (d) Remove carriage rear rail.
 - (e) Remove codebar tie bracket at left side of printer.
 - (f) Rotate main shaft until codebar cam follower arm is riding on low part of codebar cam.
 - (g) Loosen four codebar mounting screws and remove codebar clamp from under each mounting screw.
 - (h) Lift blocking levers from their guide slots in front tie bracket.
 - (i) Remove codebar basket.
- 2.08 Reassemble codebar mechanism by reversing procedure in 2.07.

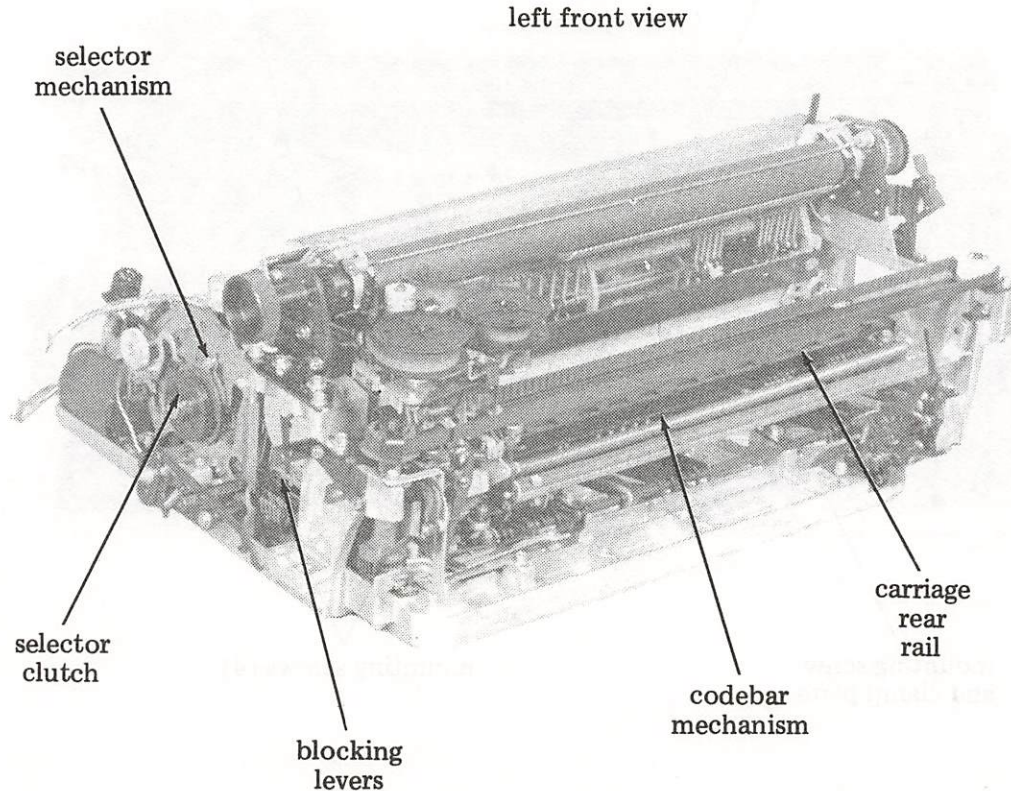

Figure 2 - Selector and Codebar Mechanisms

FUNCTION BOX MECHANISM

- 2.09 Disassemble function box mechanism (Figure 3) as follows:
- Disassemble carriage mechanism as outlined in 2.01.
 - Disassemble platen mechanism as outlined in 2.03.
 - Unhook spring connected between codebar reset bail and plate.
 - Loosen two mounting screws and remove two clamp plates.
 - Lift function box mechanism from printer casting.

- 2.10 Reassemble function box mechanism by reversing procedure in 2.09.

TRIP SHAFT MECHANISM

- 2.11 Disassemble trip shaft mechanism (Figure 3) as follows:
- Loosen four screws (two at left and right mounting brackets).
 - Push brackets inward and lift trip shaft mechanism from printer casting.
- 2.12 Reassemble trip shaft mechanism by reversing procedure in 2.11.

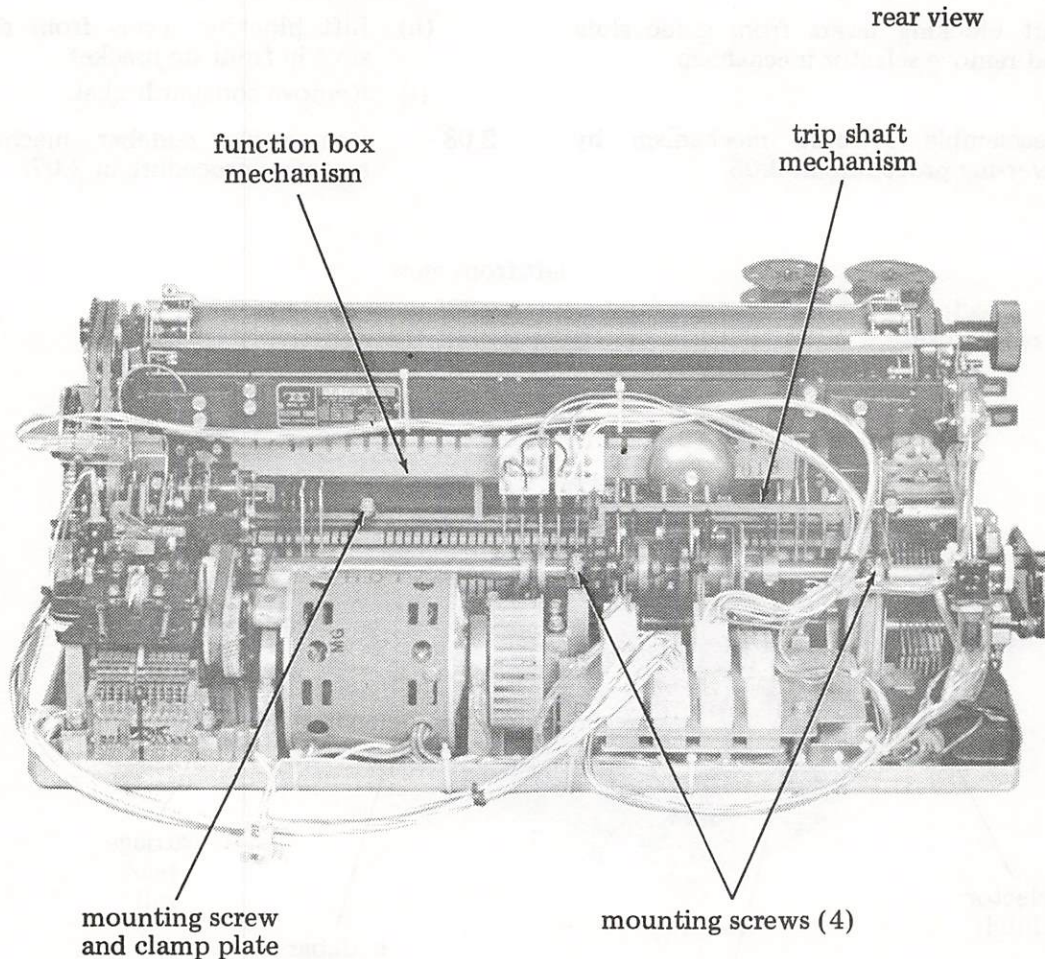

Figure 3 - Function Box and Trip Shaft Mechanisms

MOTOR

- 2.13 Disassemble motor (Figure 4) as follows:
- (a) Remove four screws and two clamps from motor mount.
 - (b) Disengage belt from gear pulley at right of motor.
 - (c) Loosen motor start relay mounting screw.
 - (d) Remove plastic cable ties from motor wiring.
 - (e) Remove motor, start capacitor, start relay, and motor wiring.
- 2.14 Reassemble motor by reversing procedure in 2.13.

FORM-OUT MECHANISM

- 2.15 Remove form-out mechanism (Figure 4) as follows:
- (a) Remove brush holder mounting screw, brush holder, and brush.
 - (b) Loosen distributor disc mounting screws and move disc until it is clear of form-out mechanism.
 - (c) Loosen idler nut, back off idler wheels, and remove two idler belts.
 - (d) Disengage spring from form-out latch-lever assembly.
 - (e) Work form-out mechanism upward and remove.
- 2.16 Reassemble form-out mechanism by reversing procedure in 2.15.

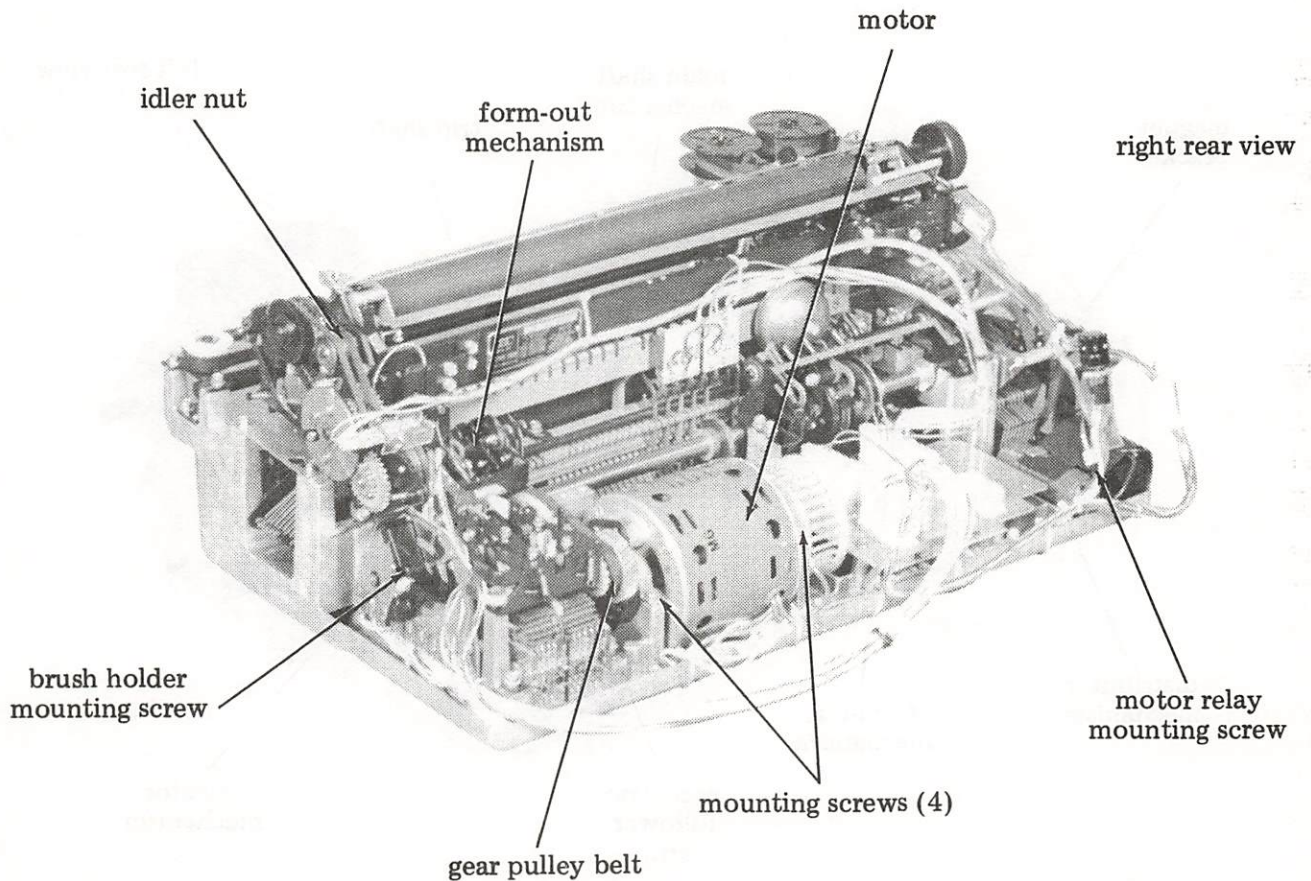

Figure 4 - Motor and Form-Out Mechanisms

MAIN SHAFT MECHANISM

- 2.17 Disassemble main shaft mechanism (Figure 5) as follows:
- (a) Remove trip shaft mechanism.
 - (b) Remove selector mechanism.
 - (c) Remove motor.
 - (d) Remove form-out mechanism.
 - (e) Remove nut and flat washer from pivot shaft attached to underside of carriage drive bail.
 - (f) Disengage front end of carriage link from pivot shaft.
 - (g) Remove retaining ring from eccentric follower arm.
 - (h) Disengage eccentric follower arm from function rocker shaft.
 - (i) Slide main shaft to right and lift from casting.
- 2.18 Reassemble main shaft mechanism by reversing procedure in 2.17.

DISTRIBUTOR MECHANISM

- 2.19 Disassemble distributor mechanism (Figure 5) as follows:
- (a) Remove mounting screw and brush holder.
 - (b) Loosen three distributor disc mounting screws.
 - (c) Remove mounting screw, magnet bracket, and clutch trip mechanism.
 - (d) Loosen bearing mounting screw and remove bearing clamp.
 - (e) Loosen screw and remove bracket.
 - (f) Loosen two screws that mount the right bracket.
 - (g) Remove belt from motor.
 - (h) Lift distributor mechanism from casting.

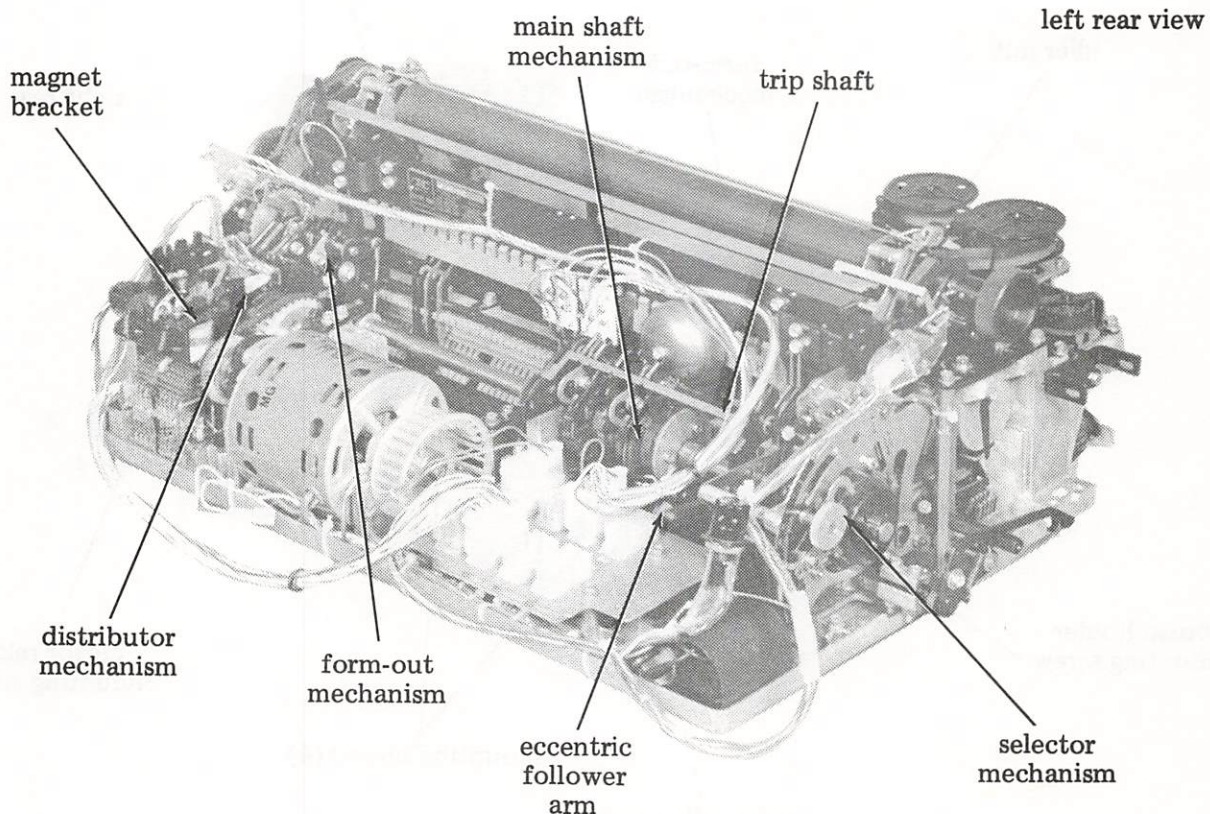

Figure 5 - Main Shaft and Distributor Mechanisms

2.20 Reassemble distributor mechanism by reversing procedure in 2.19.

FUNCTION ROCKER SHAFT

2.21 Remove function rocker shaft (Figure 6) as follows:

- (a) Remove trip shaft.
- (b) Remove form-out.
- (c) Remove main shaft.

(d) Remove retaining rings from posts at rear of left and right function bail drive links.

(e) Loosen two mounting screws and remove left and right function rocker shaft bearing clamp plates.

(f) Lift function rocker shaft from casting.

2.22 Reassemble function rocker shaft by reversing procedure in 2.21.

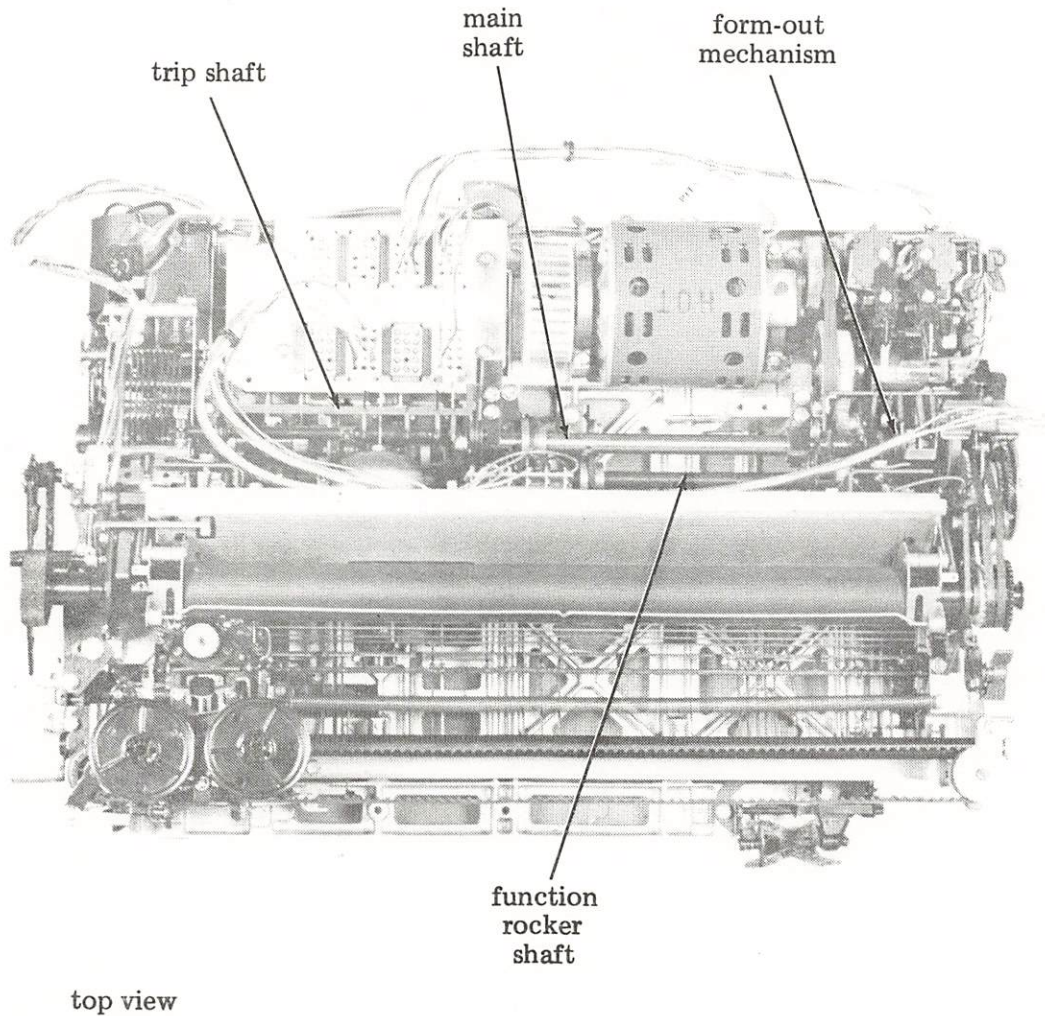

Figure 6 - Function Rocker Shaft

38 ELECTRICAL SERVICE UNITS

DESCRIPTION AND OPERATION

| CONTENTS | PAGE |
|---------------------------------------------------------------------------------------------------|------|
| 1. GENERAL | 1 |
| 2. ELECTRICAL SERVICE UNIT PROVIDING DC AND EIA INTERFACE (WESU001) | 1 |
| DESCRIPTION | 1 |
| TECHNICAL DATA | 2 |
| A. Signal and Control Interface | 2 |
| B. Physical, Electrical, and Environmental Characteristics | 3 |
| OPERATION | 3 |
| 3. ELECTRICAL SERVICE UNIT PROVIDING FSK (FREQUENCY SHIFTED KEYING) INTERFACE (WESU002) | 10 |
| DESCRIPTION | 10 |
| TECHNICAL DATA | 10 |
| A. Interface | 10 |
| B. Carrier Frequencies | 10 |
| C. Signal Level | 10 |
| D. Physical, Electrical, and Environmental Characteristics | 10 |
| OPERATION | 10 |
| A. Modem Card (322490) 1216SD | 11 |
| B. Logic Card (322491) 1227SD | 11 |

1. GENERAL

1.01 This section provides the description and operation of the 38 electrical service units. It is reissued to make some additions and minor corrections. Marginal arrows ←

indicate the changes and additions. If a detailed circuit description is required, refer to the appropriate WDP (Wiring Diagram Package).

1.02 Two types of electrical service units are covered in this section. The first unit to be covered (WESU001) provides both dc (current/no current), and EIA (Electronics Industries Association) Standard RS-232-C interfacing. The second unit to be covered (WESU002) uses FSK (Frequency Shifted Keying) to provide interfacing with a private telephone line or some data access arrangement. Both units can be mounted in the pedestal of the floor model or in a separate housing for the table model.

2. ELECTRICAL SERVICE UNIT PROVIDING DC AND EIA INTERFACE (WESU001)

DESCRIPTION

2.01 The physical make-up of the electrical service unit consists of a main baseplate on which is mounted a dc power supply and a circuit card assembly. Mounting facilities are also provided for various options such as a reader power pack or an elapsed timer.

2.02 A six-pushbutton cluster with internal indicator lamps, that is connected by cable to the electrical service unit, provides the operator with mode switching, break generation, and manual answer-back trip, and also a visual indication of the mode status or alarm condition. Two cables are supplied with the electrical service unit; one goes to the connector board at the rear of the printer, the other goes to the motor.

2.03 A connector assembly with spare terminals is provided for customer connection of dc signal lines. When EIA interface is used, the customer can provide his own connector or use an optional interface cable available from Teletype Corporation. There is an auxiliary connector on the circuit card that provides customer access to the "EOT" (End of Transmission) and "paper-out" contacts. The connector also provides for remote switching of the "answer-back" mechanism.

TECHNICAL DATA

A. Signal and Control Interface

2.04 The electrical service unit provides two basic types of interface to external signaling lines. The 20-60 ma type is used for special data set operations, or interoffice transfer. The EIA type is used with an external data set and may be used in a variety of applications. A control contact interface is provided that allows the customer access to certain internal control contacts.

DC Interface

2.05 Operation into a dc interface may be two-wire connected (half-duplex, Figure 1) or four-wire connected (full duplex, Figure 2).

Operating currentsat 20 ma, reliable operation will be above 12 ma
 at 60 ma, reliable operation will be above 35 ma
 upper current limit, 75 ma max

NOTE: All operating currents are supplied from an external dc battery. The open circuit signal voltage on either loop must not exceed 125 volts.

2.06 The internal signal circuits of the electrical service unit do not affect the normal input (selector) distortion tolerance or output (distributor) distortion tolerance.

2.07 When the unit is to be operated without making any physical connection to an external line, it is advisable to disconnect connector J11. This will eliminate spurious printing as the key switch buttons are pressed.

EIA Interface

2.08 Operation into an EIA device is made at P11 in accordance with the standards set up in RS-232-C. A cable can be made using a "Molex" connector according to the information supplied in Figure 3 or an optional EIA interface cable 188724 can be used. The following chart is used to describe the EIA signals present at connector P11.

EIA INTERFACE SIGNALS AT CONNECTOR P11

| PIN NO. | EIA SIGNAL | EXPLANATION |
|---------|------------------------|------------------------------------------------------------------------------------------------------------------------------|
| 1 | (AA) Protective Ground | Frame |
| 2 | (CB) Clear to Send | This lead is connected to circuit card paths which will permit adding a series resistor to "signal ground" if desired. |
| 3 | (BB) Received Data | An "ON" (+) input represents a space and an "OFF" negative voltage represents a mark. |
| 4 | (CA) Request to Send | This output is held high whenever power is applied to the set. |
| 6 | (CC) Data Set Ready | This lead controls the set motor: A (+) input voltage turns the motor "ON." A (-) input voltage turns the motor "OFF." |
| 7 | Signal Ground | Common Return |
| 8 | (BA) Send Data | A (+) output voltage represents a "SPACE." A (-) output voltage represents a "MARK." |
| 12 | (CF) Ring Indicator | See explanation for pin 2. |

EIA INTERFACE SIGNALS AT CONNECTOR P11 (Continued)

| PIN NO. | EIA SIGNAL | EXPLANATION |
|---------|-----------------------------------|---------------------------------------------------------------------------------------------------------------------------------------------------------------------------------------------------------------------------------------------------------------------------------------------------------------------------------------------------------------------------------------------------------------------------------------------------------------------------------------------------------------------------------------------------------------------------------------------------------------------------------------------------------------------|
| 13 | (CF) Receive Line Signal Detector | See explanation for pin 2. |
| 15 | (CD) Data Terminal Ready | This output is held "ON" (+) when any of the following conditions exists. <ol style="list-style-type: none"> The EOT switch (in the printer base) is not sensing an EOT. The LOCAL pushbutton has not been depressed. The OFF pushbutton has not been depressed. Paper is available on the printer (ie, paper-out switch is not sensing paper out). Option 2 shunts the paper-out contacts. The data terminal ready signal is then no longer dependent upon these contacts. By adding Option 3, the paper-out switch contacts are bypassed and the Data Terminal Ready signal is no longer dependent upon those contacts. |

Control Contact Interface

2.09 Connector P20 on the circuit card assembly (Figures 4 and 5) affords access to the "paper-out" and "EOT" contacts and provides connection for a parallel "HERE IS" contact to operate the answer-back trip magnet.

NOTE: The circuit card assembly comes supplied with a dummy connector (J20) which completes the contact circuitry in those instances where the customer has no need for the contact interface provided at P20.

2.10 There is an additional "Option 2" (Figure 4) provided at P20. This option strap disables the normally closed "paper-out" contact (contact will be shunted). Using a dc interface, if this contact were not shunted, the set motors would turn off in the event of a "paper-out" (form-feed sets) a "low-paper" (friction feed sets) condition at the printer. Using a EIA interface, if this contact were not shunted, there would be an OFF signal at the "Data Terminal Ready" lead and the "Send Data" lead in the event of a paper-out condition.

B. Physical, Electrical, and Environmental Characteristics

- (a) Weight 18 pounds
- (b) Input power 115 v ac +10%,
47.5 to 63 Hz,
single phase (3-wire)
- (c) Power consumption maximum
300 watts

(d) Relative humidity 2% to 95%

Temperature Ranges —

This equipment is intended to be operated in a room environment within the temperature range of 40°F to 110°F. Serious damage to it could result if this range is exceeded. In this connection, particular caution should be exercised in using acoustical or other enclosures.

OPERATION

2.11 The operation of this electrical service unit will be on a functional basis. At times, key electronic components will be discussed when knowledge of their operation is needed in understanding signal flow. This operation should be used in conjunction with the block diagram found in WDP0320.

Signal Circuits (Receive) 1194SD-B1

2.12 The signal input circuits respond to the incoming signals (received data) in the following manner. A marking signal input (minus voltage in EIA, "current on" in dc) is the equivalent of a low at the 3-input OR gate which represents the input circuit. Similarly, the closure of the LOCAL pushbutton switch contact will apply a ground (low) at the 3-input OR gate. Any low at the 3-input OR gate is inverted by transistor Q5 and will appear as a high at a "wired and" connection. The "wired and" combines the LINE pushbutton switch input with the inverted output from the 3-input OR gate. With the LINE pushbutton not depressed, the "wired and" out-

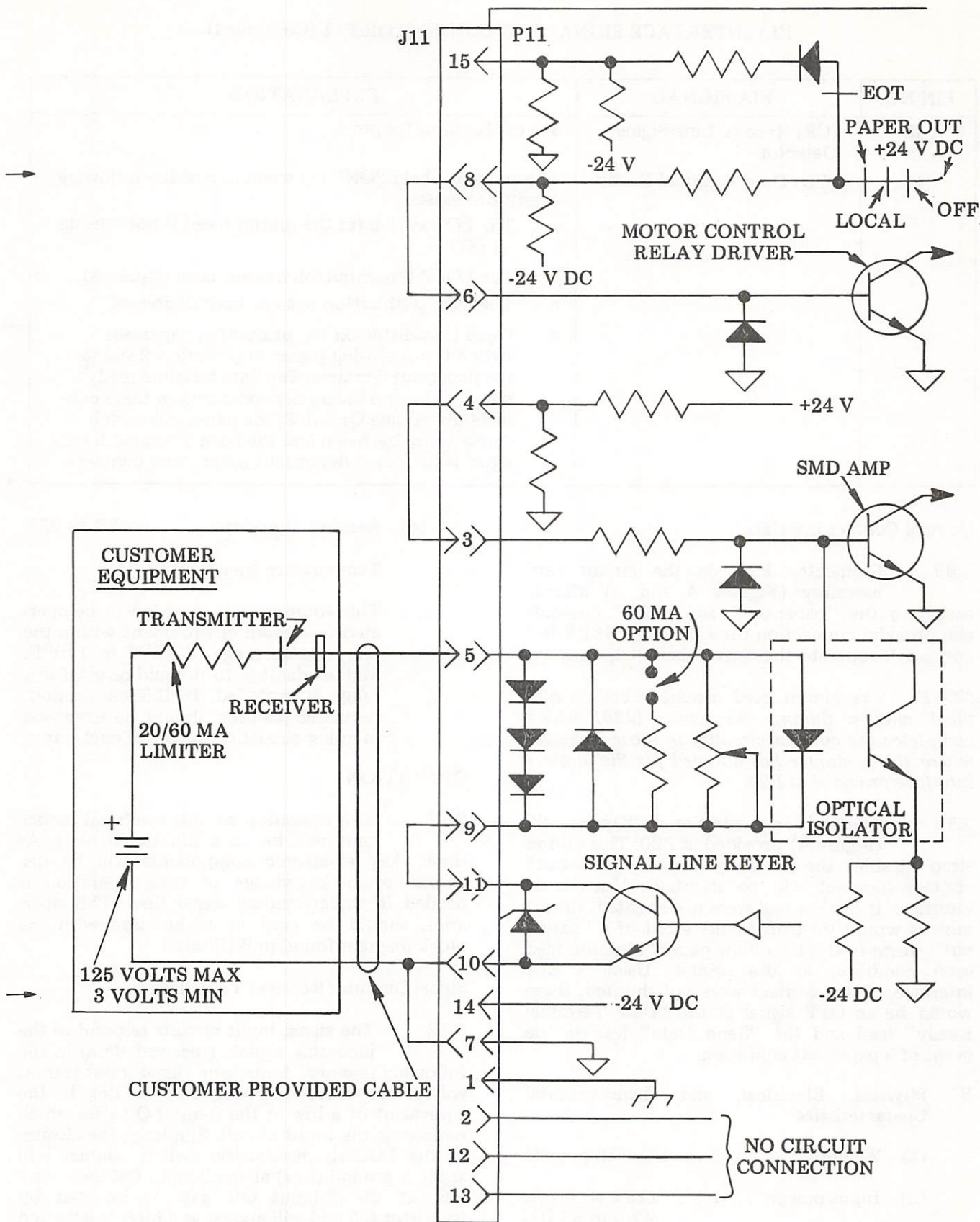

Figure 1 - Wiring for DC Half-Duplex (2-Wire) Operation

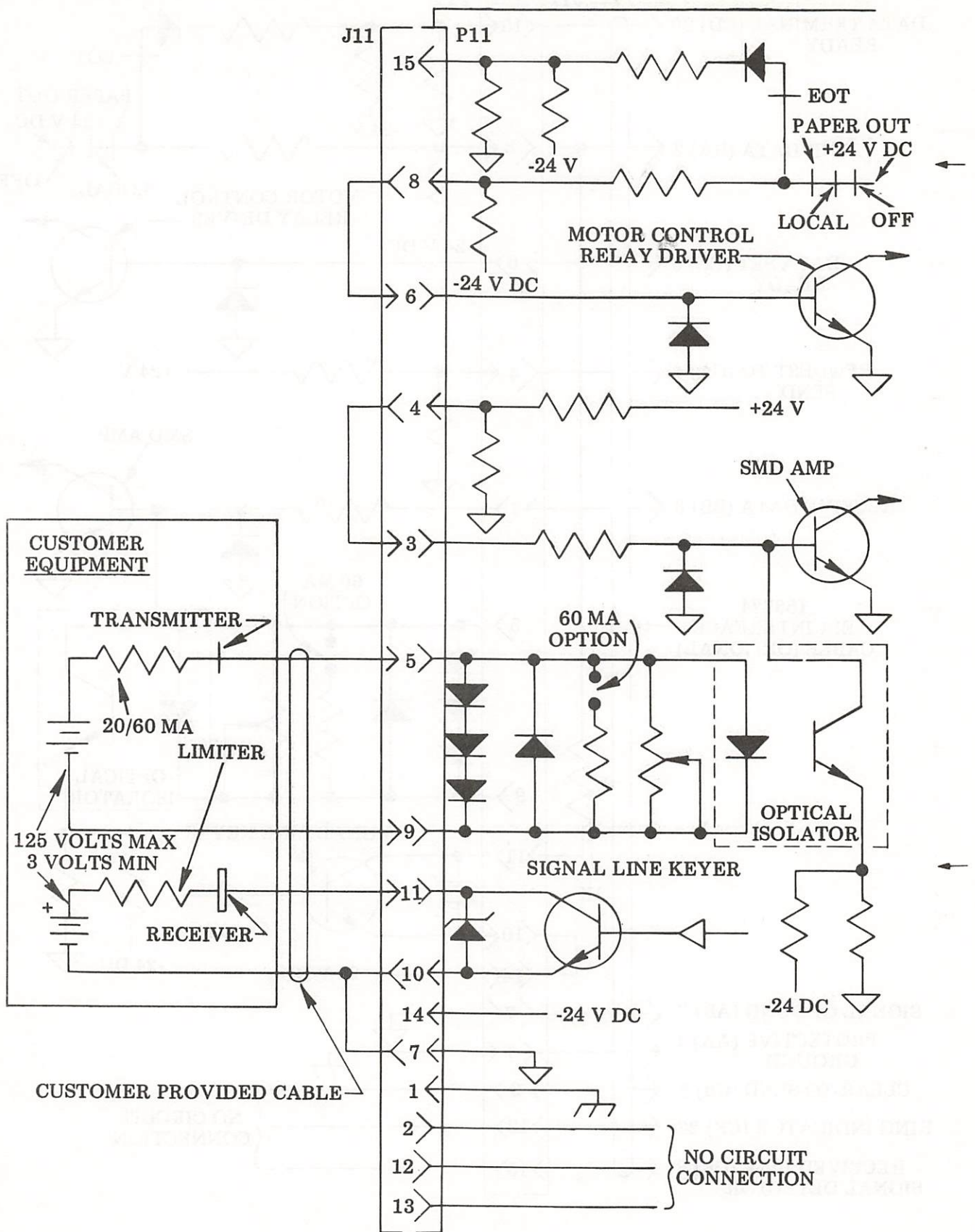

Figure 2 - Wiring for DC Full Duplex (4-Wire) Operation

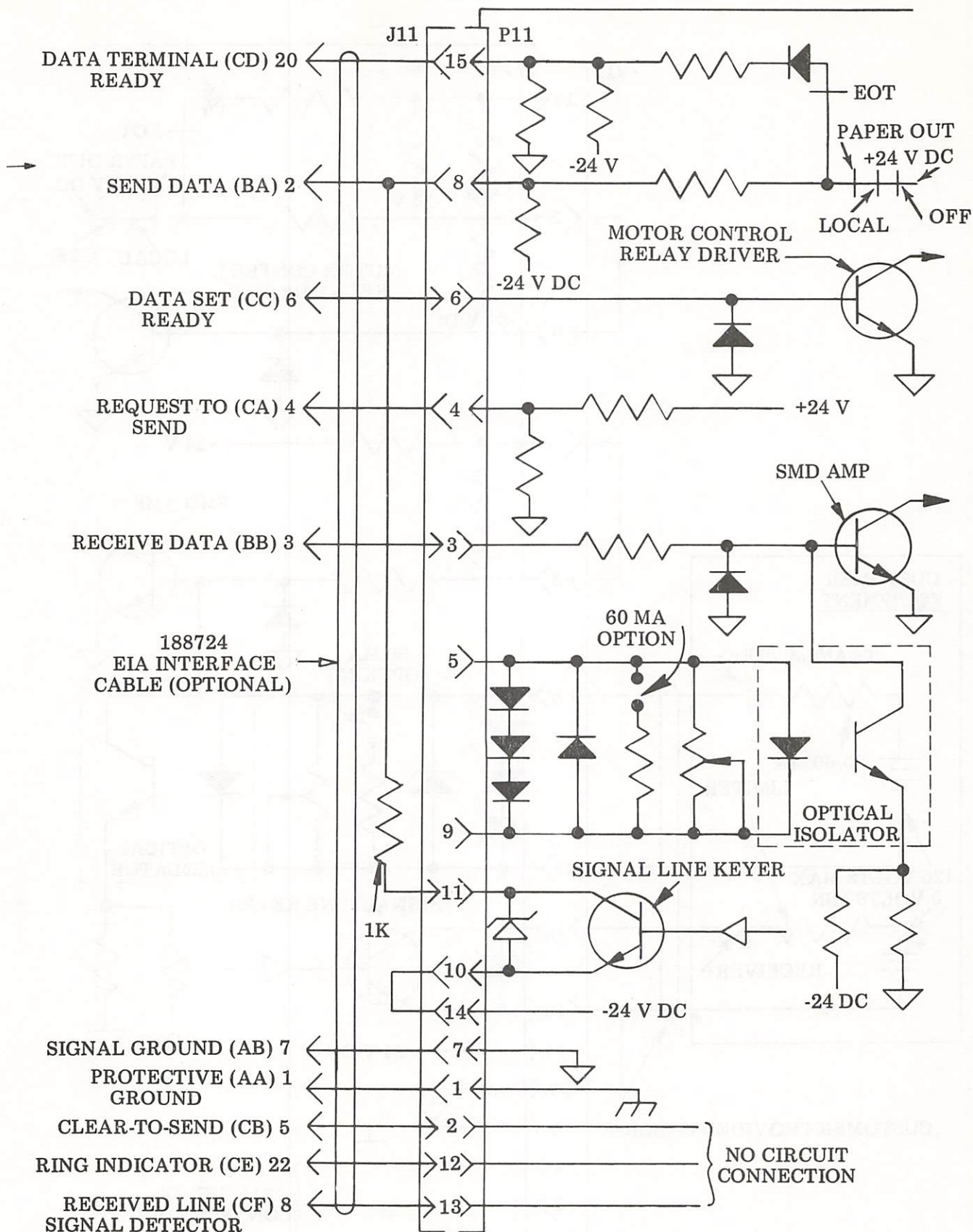

Figure 3 - Wiring for EIA Operation

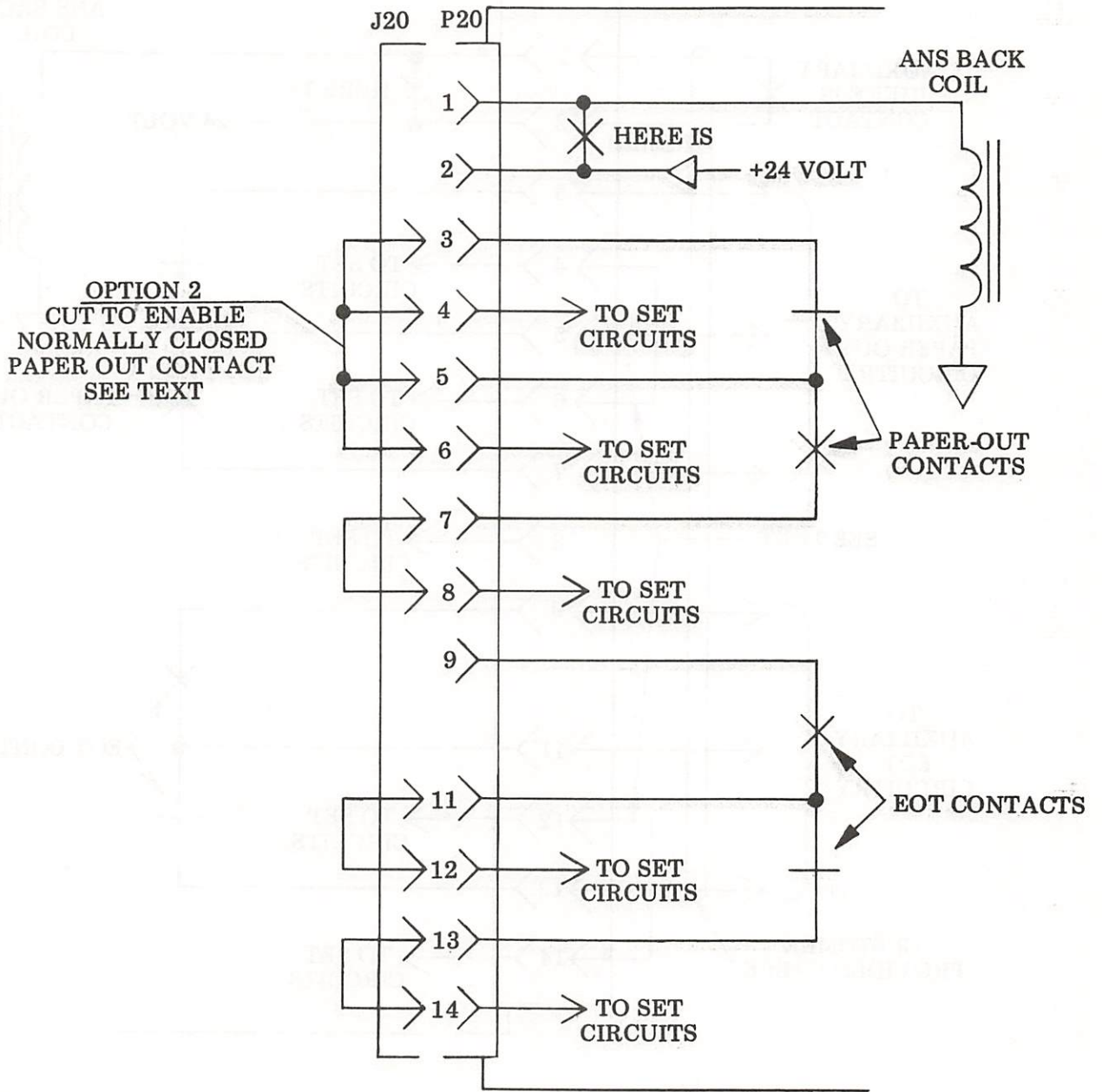

Figure 4 - Wiring for Control Contact Interface With Connector J-20 Installed

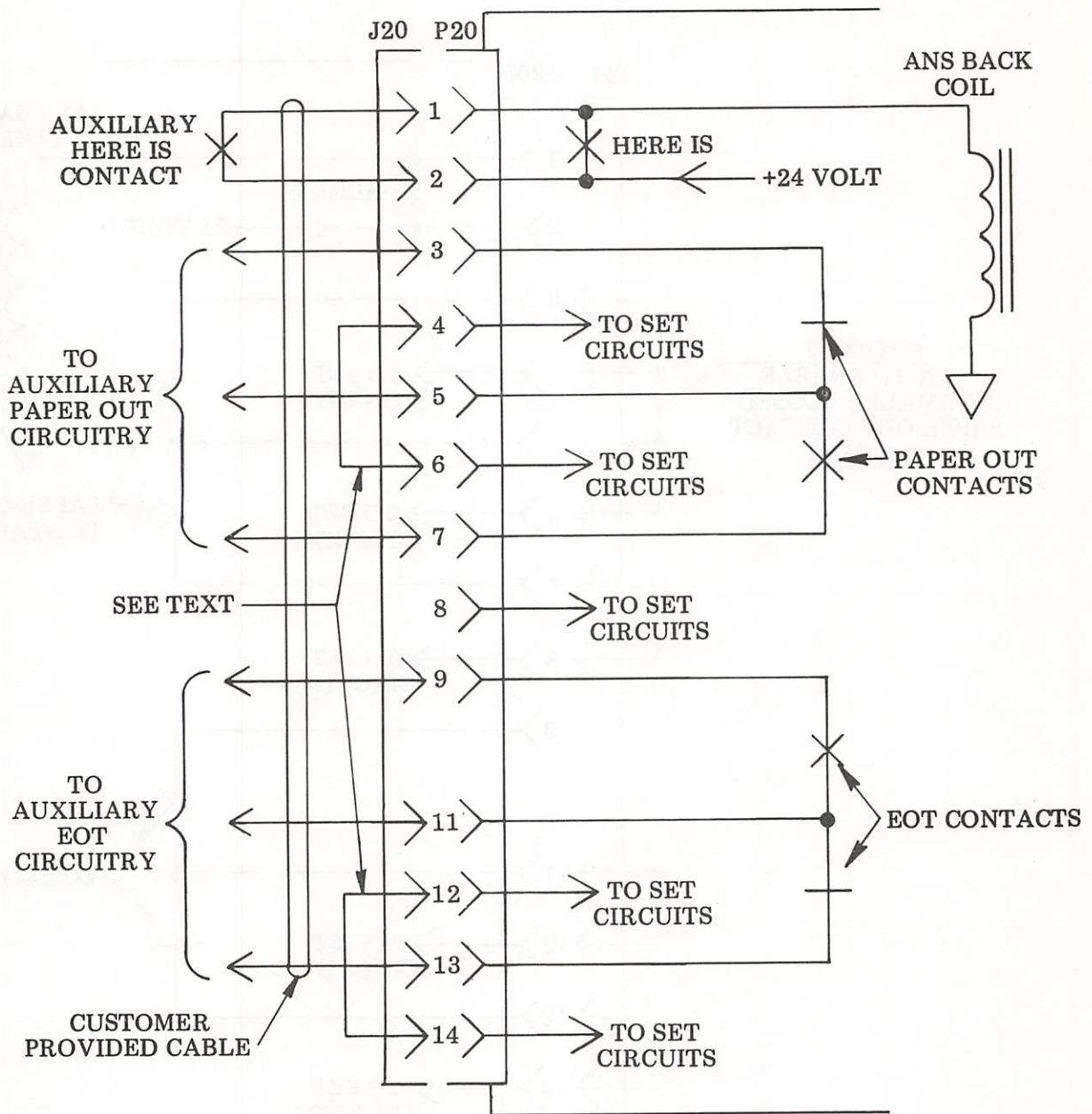

Figure 5 - Wiring for Control Contact Interface Showing Possible Customer Connection

put will be high when the input circuits are marking, and low when all the OR gate inputs are high.

2.13 The "wired and" output is inverted by transistor Q2 and applied to the selector magnet coils. The output of Q2 follows the 3-input OR gate output and therefore energizes the selector magnet (marking condition) whenever any input is low (marking).

NOTE: The high appearing at the input of Q2 must be supplied by the LINE FDX switch (either directly or from transistor Q3) or through the OFF switch contacts and paper alarm contact. The absence of a high at Q2 constitutes a space; therefore, in LOCAL the high or low input to Q2 is determined by the distributor contacts or BREAK switch contact.

Signal Circuits (Send) 1194SD-B3

2.14 The signal output circuits generate EIA or dc signals in the following manner. Interruption of the circuit common ground at inverter Q3 will present a low at the input of Q7 which will result in a high at the output of Q7. This high is transmitted as a spacing signal. Conversely, closure of the circuit common results in a marking signal. The signal line keyer (Q7) output is also dependent upon the LINE FDX contact and LINE contact so that whenever the set is in LOCAL or OFF mode, the +24 volt input through these contacts holds the keyer output marking.

Mode Control 1194SD-B4

2.15 The mode control circuits respond to the operator input (pushbuttons) which place the set into various modes of operation; OFF, LOCAL, LINE, and LINE FDX. The LOCAL, LINE, and LINE FDX lamps are lighted directly through closure of the associated switch contact. The ALARM lamp is lighted by closure of a "paper alarm" contact or "low-tape" (optional) contact to ground. The "data terminal ready" output provides a positive output (ready) only when the following conditions exist:

- (1) The "paper alarm" contact is closed (paper not out or low).
- (2) The OFF switch contact is closed (OFF pushbutton not depressed).
- (3) The LOCAL switch contact is closed (LOCAL pushbutton not depressed).
- (4) The EOT contact is closed (EOT contact opens momentarily when the set receives the EOT code character).

Reader and Answer-Back Controls 1194SD-B5

2.16 The operation of the reader is directly controlled by the distributor trip magnet. When the magnet is energized, it provides for the mechanical pulsing of the reader feed contact. It is the periodic opening and closing of this contact which pulses the reader feed magnet (stepping motor).

2.17 With the reader control lever in the START position, the TDC relay will energize through the paper alarm contacts, the OFF switch contact, the reader control switch contacts, and through the ENQ, DC-3, and EOT contacts. A set of relay contacts (TDC-2) shunts the start contact to hold the reader ON.

2.18 With the reader control lever in the ON position, the reader can be started remotely by receiving a DC-1 character. This provides a momentary shunt across the start contact. The TDC relay will energize, causing the reader to stop when the following conditions exist:

- (1) Reader control in STOP or FREE position
- (2) A tape-out or tight-tape condition
- (3) A momentary opening of the EOT, DC-3, or ENQ contact
- (4) A paper-out alarm condition.

2.19 Along with the control by the TDC-3 relay contact the distributor trip magnet is also directly controlled by a STEP contact on the reader control switch or by the form-feed contact within the printer. The STEP is closed when the reader control switch is placed in the STEP position. It will remain closed for one character cycle, opening automatically when the cycle is complete.

2.20 The answer-back trip magnet (which controls the starting and stopping of the answer-back mechanism) is dependent upon the contact of the HERE IS switch and (in sprocket feed sets) also upon the form-feed sets.

Motor Control

2.21 Contacts of the motor control relay turn the set motor ON when the relay is energized. The motor control relay is energized when a ground is applied to the coil through the LOCAL switch contact, the "forming out" contacts (in sets using sprocket feed printers), or through the OFF switch. A ground is developed

at Q4 (relay driver) in response to a "data set ready" input (EIA interface) or from internal circuitry (dc interface).

Power Distribution

2.22 Line power is applied from the power cord directly to a convenience receptacle, and through a set fuse F1 (A) to the remainder of the set. A second fuse F2 protects the dc power supply. A third fuse F1 (B) on the power supply rectifier regulator board is part of an overvoltage protection circuit associated with the 6 volt supply.

3. ELECTRICAL SERVICE UNIT PROVIDING FSK (FREQUENCY SHIFTED KEYING) INTERFACE (WESU002)

DESCRIPTION

3.01 The physical make-up of the electrical service unit consists of a main baseplate on which is mounted a dc power supply and two circuit card assemblies. Mounting facilities are also provided for various options such as a reader power pack or an elapsed timer.

3.02 Two six-pushbutton clusters with internal indicator lamps, that are connected by cable to the electrical service unit, provides the operator with mode switching and a visual indication of the mode status or alarm condition. Three cables are supplied with the electrical service unit; one goes to the connector board at the rear of the printer, one to the motor, and one provides connection to the telephone line or a data access arrangement.

TECHNICAL DATA

A. Interface

3.03 The interface cable connects to connector 16 on the circuit card. If an automatic DAA is used, the connections are as follows:

| WIRE | DAA TERMINAL |
|--------|--------------------------|
| Blue | -V) |
| White | +V) DC for DAA Operation |
| Black | DA) Data Transmission |
| Green | OH) Off Hook |
| Yellow | RI) Ring Indicator |
| Orange | DT) Data Tip |
| Red | DR) Data Ring |

NOTE: For connection to a manual DAA or private line, only DT and DR leads are connected.

B. Carrier Frequencies

| | |
|------------------------------|-------------------------------------------------------|
| Originate (transmit - F1) | 1070 Hz (space) 1270 Hz (mark) <u>+1-1/2 Hz</u> |
| Originate (receive - F2) | 2025 Hz (space) 2225 Hz (mark) <u>+1-1/2 Hz</u> |
| Answer (transmit - F2) | 2025 Hz (space) 2225 Hz (mark) <u>+1-1/2 Hz</u> |
| Answer (receive - F1) | 1070 Hz (space) 1270 Hz (mark) <u>+1-1/2 Hz</u> |

C. Signal Level

| | |
|--------------------------|-----------------------------------------|
| Transmit signal level | 0 to -12 dBm (continuously variable) |
| Receive signal level | 0 to -50 dBm (mean sensitivity) |

D. Physical, Electrical, and Environmental Characteristics

- (a) Weight 18 pounds
- (b) Input power 115 v ac $\pm 10\%$,
47.5 to 63 Hz,
single phase (3-wire)

Power consumption maximum
300 watts

Relative humidity 2% to 95%

Temperature Ranges -

This equipment is intended to be operated in a room environment within the temperature range of 40°F to 110°F. Serious damage to it could result if this range is exceeded. In this connection, particular caution should be exercised in using acoustical or other enclosures.

OPERATION

3.04 The operation of this electrical service unit will be on a functional basis. At times, key electronic components will be dis-

cussed when knowledge of their operation is needed in understanding signal flow. This operation should be used in conjunction with the block diagram found in WDP0344. The two circuit cards used in this electrical service unit will be covered individually.

A. Modem Card (322490) 1216SD

Modulator

3.05 The clock consists of an NPN transistor (Q9) Pierce crystal oscillator operating at 1000, 640 Hz, and another NPN transistor (Q8) used as a buffer amplifier. It is possible to use the collector output of Q8 which is available at terminal 10 of J2, as an external clock whenever +6 v dc is applied to terminal 2 of J2.

3.06 The collector output of Q8 drives the first of nine J-K flip-flops which are wired as a ripple-carry binary divider chain. The flip-flop outputs, together with the clock (which inhibit all outputs during the counting ripple), transmit band selection and dc data signal. These outputs selectively are programmed as inputs to the four sets of AND gates.

3.07 Depending on the control voltages from the logic card, terminals 1 and 4 of connector J2, one set of AND gates will have all its inputs high after the divider has progressed to the proper integer: 467 for 1070 Hz, 394 for 1270 Hz, 247 for 2025 Hz, and 225 for 2225 Hz. This number represents twice the frequency which is then divided by 2 by the 10th flip-flop to generate a square wave at the desired frequency.

NOTE: For clarity, the remainder of this description will refer only to the low band operation, ie, 1070 Hz and 1270 Hz, corresponding to divisors of 467 and 394. For high band operation, substitute 2025 Hz and 2225 Hz, corresponding to divisors of 247 and 225, respectively.

3.08 When the proper set of AND gates corresponding to 1070 Hz (F1) is made high, a low is presented to the trigger input of the 10th flip-flop, and also to the SD (Set Direct) terminals of the other nine flip-flops resetting the count to zero. The low at the SD terminals of the flip-flops is immediately removed by the reset action.

3.09 When the proper set of AND gates corresponding of 1270 Hz (F2) is made high, a low is transferred through two interposing

NAND gates (normally effective as inverters) to the trigger input of the 10th flip-flop, and the SD terminals of the other nine flip-flops also resetting the count to zero.

Demodulator

3.10 The carrier signals received on terminals 12 and 15 of connector J2 are stepped up by transformer T1 to properly drive the input filter. When receiving the high band, the high-pass filter passes the received signals while attenuating the low band signals being transmitted. When receiving the low band, the low-pass filter passes the received signals for demodulation while blocking the transmitted high band.

NOTE: When the transmitted signal is high-pass filtered, the received signal is processed by the low-pass filter; when the transmitted signal is low-pass filtered, the received signal is passed by the high-pass filter.

3.11 Most of the demodulator gain and limiting is provided by a linear integrated circuit operational amplifier 709C. It is followed by three discrete NPN transistors: a phase-inverter Q4 and a class B push-pull pair Q2 and Q3, whose output drives the two discriminator transformers T2 and T3. Transformer T2 resonates at a frequency higher than mark (1270 Hz or 2225 Hz) while T3 resonates at a frequency lower than space (1070 Hz or 2025 Hz). Both T2 and T3 secondaries are center-tapped to provide full-wave detection, with the direct current outputs arranged in series so that spacing (T3) is negative and marking (T2) is positive. The sum of these two outputs is presented to the gate of the FET amplifier.

Carrier Detection

3.12 The secondary voltages of T2 and T3 are tapped by capacitors C36 and C35 respectively, and divided by capacitor C6 so that either marking or spacing carrier is rectified by the base emitter junction of transistor Q5. Transistor Q6 amplifies and inverts the output of Q5 so that terminal 8 of connector J2 is "high" when an adequate carrier is being received, and "low" when no carrier is being received.

B. Logic Card (322491) 1227SD

Send Data

3.13 In a marking state, transistor Q10 is "on" and resistor divider R28 and R30 provide a high at pin 9 of A3. During a space, transistor Q10 will be "off" and a low will be present at pin 9 of A3.

Receive Data

3.14 The receive and send data is coupled to the selector magnets through one of three gates and transistors Q11 and Q14. In a marking state, the outputs of the gates are all high. This will turn on transistors Q11 and Q14 and energize the selector magnets. Gate A2-4, A2-5, and A2-6 is used for local copy in the local mode. Gate B3-1, B3-2, and B3-3 is used to control local copy via the FDX and ECHO pushbuttons in the on-line mode. Gate B3-4, B3-5, and B3-6 monitors the demodulator. For a mark condition to occur, each of the three gates must have one input low. For a space condition, at least one of the three gates must have both of its inputs high.

Off-Hook, Tape Reader, and Motor Control

3.15 In the on-line mode gate A3-1 is low while A3-2 is high. Transistor Q13 is "on" which will energize the off-hook and motor control relays, enabling the tape reader control relay. In the local or clear modes gate A3-1 is high while A3-2 is low. Transistor Q13 is "off," therefore the off-hook, motor control, and tape reader control relays are de-energized.

On-Line and Modulator Control

3.16 The flip-flop C3-1, C3-2, C3-3, C3-4, C3-5, and C3-6 by a momentary low on pin 5 resets the flip-flop so that it can respond to one of three on-line modes: Automatic Answer, Manual Answer, and Manual Originate. During reset, C3-3 will be low and C3-6 will be high.

Automatic Answer

3.17 Automatic answering is accomplished by the RI (Ring Indicator) contact (in automatic DAA) closing in response to the ringing pulses of an incoming call. A low will then be present at gate C3-1 putting the flip-flop in the on-line mode.

Manual Answer

3.18 Normally, gate A1-13 is low causing A1-12 to be high; this has no effect on the flip-flop. When the answer key is depressed A1-13 goes high and A1-12 goes low which therefore causes the flip-flop to place the set in the on-line mode.

Manual Originate

3.19 Gate A1-1 monitors the originate/answer flip-flop. The answer mode presents a low to gate A1-1 and therefore a high

on A1-2 which has no effect on the RS flip-flop. If the originate/answer flip-flop is set to the originate mode, A1-1 goes high, A1-2 goes low, which causes the RS flip-flop to place the set in the on-line mode.

3.20 Gate B3-8, B3-9, and B3-10 couples the send data in the on-line mode through gate A3-5 and A3-6 to the modulator. A low on B3-8 causes a high at A3-6 which is equivalent to a spacing condition. Gate B3-11, B3-12, and B3-13 is used to turn the demodulated signal around to the modulator in the echo mode. Input B3-12 monitors the ECHO key which is normally low. In the echo mode B3-12 goes high which will couple the modulator to the demodulator.

Originate/Answer Mode Control

3.21 The originate/answer flip-flop gates A2-8, A2-9, A2-10, A2-11, A2-12, and A2-13 determine the two on-line operating modes, originate or answer. The flip-flop is reset when a low is present on A2-9. When A2-8 is low, B2-12 will be high, and transistors Q8 and Q7 will be "on," thus energizing the originate relay. The flip-flop will remain in this state until the ANS pushbutton is depressed or a low is present on A2-9; the flip-flop is now in the answer mode.

Carrier Control, Originate/Answer Lamp Circuits

3.22 When gate B2-3 monitors a carrier detector, it will be high. Gate B1-1 monitors the originate/answer flip-flop and is high in the answer mode. Gate B1-2 goes high when a carrier is received; this presents a low at B1-12 forcing B1-11 high which will turn transistor Q1 on illuminating the answer lamp. In addition, the answer lamp will flash when the R1 contact (in an automatic DAA) responds to the ringing pulses of an incoming call.

3.23 When gate A2-2 monitors a carrier detector, it will be high. A2-1 will be high when the flip-flop is in the originate mode. Transistor Q9 which is normally "on," will turn "off" when A2-3 goes low. This allows capacitor C5 to charge and the monostable multivibrator C1 to time-out, before C1-6 goes high which turns "on" transistor Q2, and illuminates the originate lamp. At this time, C1-8 goes low causing C2-8 to flip and go low. This low is presented to B1-4 making B1-6 high which turns the local carrier "on."

3.24 If the remote carrier is lost or the set is switched out of the originate mode, the circuits will revert to its normal condition by turning Q9 "on" which causes C1-6 and C1-8 to toggle back to a reset state. However, C2-8 does

not revert back to the reset state until the on-line flip-flop is reset and a low is present at C2-10. In the answer mode, gate B1-8, B1-9, and B1-10 present a low to B1-5 causing the local carrier to turn "on."

Answer-Back Control

3.25 Gate B2-5 (which is normally high) will be low when a carrier has been received from a remote station. Gate B2-9 (which is normally high) will be low in the answer mode. When either or both gates B2-5 and B2-9 are high, C2-6 will be reset high. At this time C3-9 is high and C3-10 is low forcing a high at C3-8, C3-12, and C3-13; consequently, C3-11 will be low and transistor Q12 is "off."

3.26 When gates B2-5 and B2-9 are both low, C3-11 will be high, turning transistor Q12 "on," energizing the answer-back trip magnet. C2-1 monitors the send data and is low in the marking state. The first mark to space transition from the answer-back switches C2-6 low and as a result C3-11 goes low turning Q12 "off," de-energizing the answer-back trip magnet.

Power On — Reset

3.27 When power is applied to the card, capacitor C6 is allowed to charge through A1-11 holding this input low for a short period of time. This will keep A1-6 which is connected to the various circuit resets, low. After C6 charges high enough, A1-6 will go high leaving all points at reset. Diode CR2 limits the voltage that C6 can charge up to, while CR1 is used to discharge C6 during power shut down.

Abort Timer

3.28 The abort timer couples the low on Q5 drain to source, so that if the level on the drain does not go high in the abort time interval, a reset occurs. Normally, the on-line input to A3-13 is low when not in the "on" state, which allows transistors Q4, Q6, and Q3 to couple a -12 volts to the gate of Q5 which will keep it off. When the on-line condition is present at A3-13, Q5 will turn "on."

Local Reset

3.29 When in the local mode, a high is coupled to the input of A3-11 which will hold the reset circuits in a reset state. In the on-line mode, A3-11 will be low which will have no effect on the reset circuit.

38 ELECTRICAL SERVICE UNIT
DISASSEMBLY AND REASSEMBLY

| CONTENTS | PAGE |
|------------------------------------------|------|
| 1. GENERAL | 1 |
| 2. ELECTRICAL SERVICE UNIT | 1 |
| READER POWER PACK | 1 |
| POWER SUPPLY AND CIRCUIT BOARD | 1 |

1. GENERAL

1.01 This section provides disassembly and reassembly instructions for the 38 electrical service unit (ESU). It is reissued to make some corrections in 2.03 and 2.04. Marginal arrows indicate the corrections. These instructions are confined to major subassemblies only. If further disassembly and reassembly is required, refer to Section 574-423-800TC.

1.02 To remove the ESU as a unit from the teletypewriter set, refer to Section 574-400-702TC.

2. ELECTRICAL SERVICE UNIT

READER POWER PACK

2.01 Disassemble reader power pack (Figure 1) as follows:

- (a) Disconnect P1 from reader power pack circuit board.
- (b) Remove two push-on leads from stud mounted resistor.
- (c) Remove two mounting screws from plastic brackets.
- (d) Remove reader power pack.

2.02 Reassemble reader power pack by reversing procedure in 2.01.

POWER SUPPLY AND CIRCUIT BOARD

2.03 Disassemble power supply and circuit board (Figure 1) as follows:

- (a) Remove all connectors on circuit card.
- (b) Loosen lower screws of supporting brackets (Figure 2). Swing brackets rearward.

NOTE: WESU 001 has 1 circuit card; WESU 002 has 2 circuit cards.

- (c) Remove circuit cards.

2.04 To reassemble, reverse procedure. Make sure circuit card(s) are positioned properly, with their corners in the slots provided at their mounting brackets.

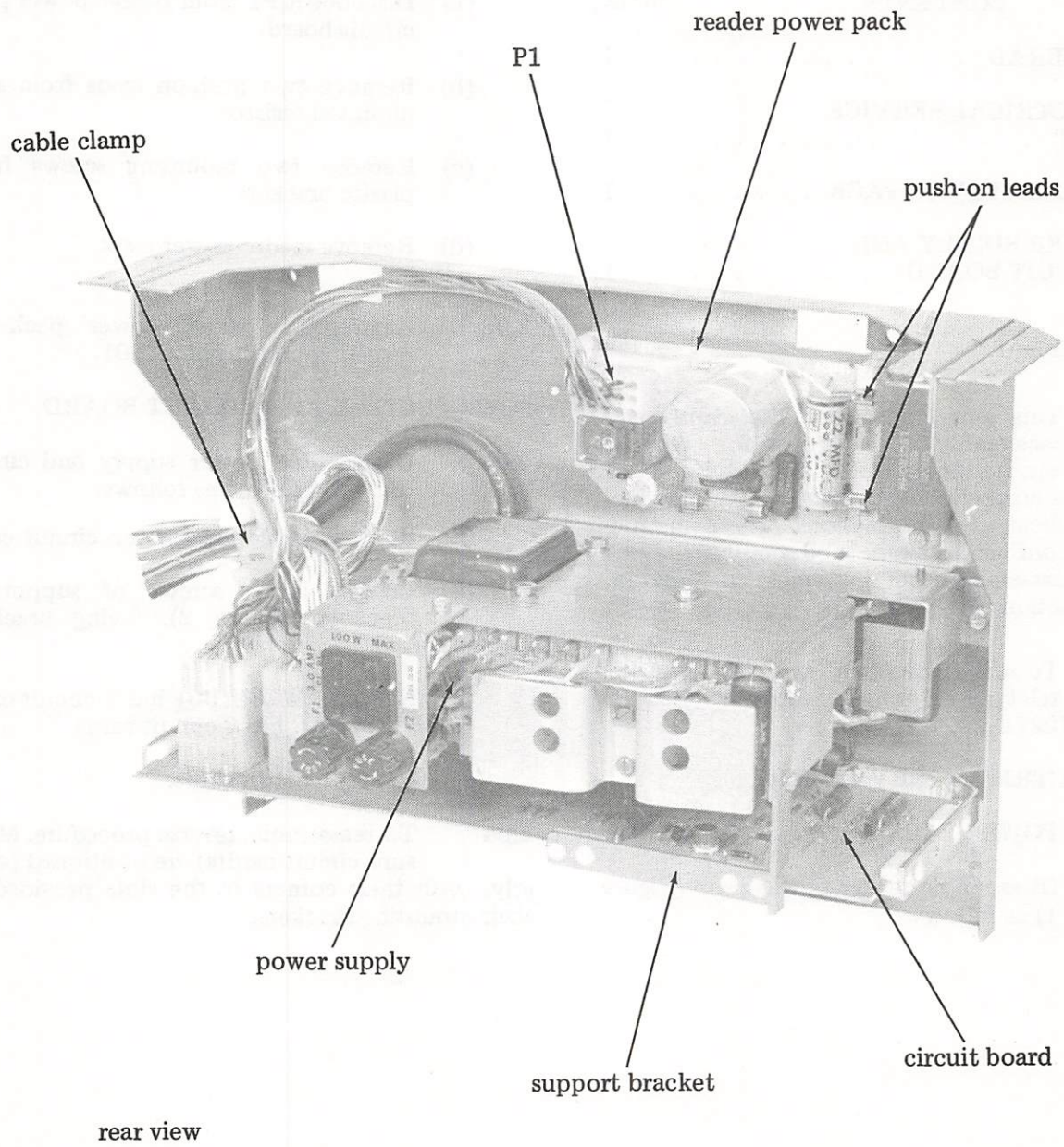

Figure 1 - Electrical Service Unit

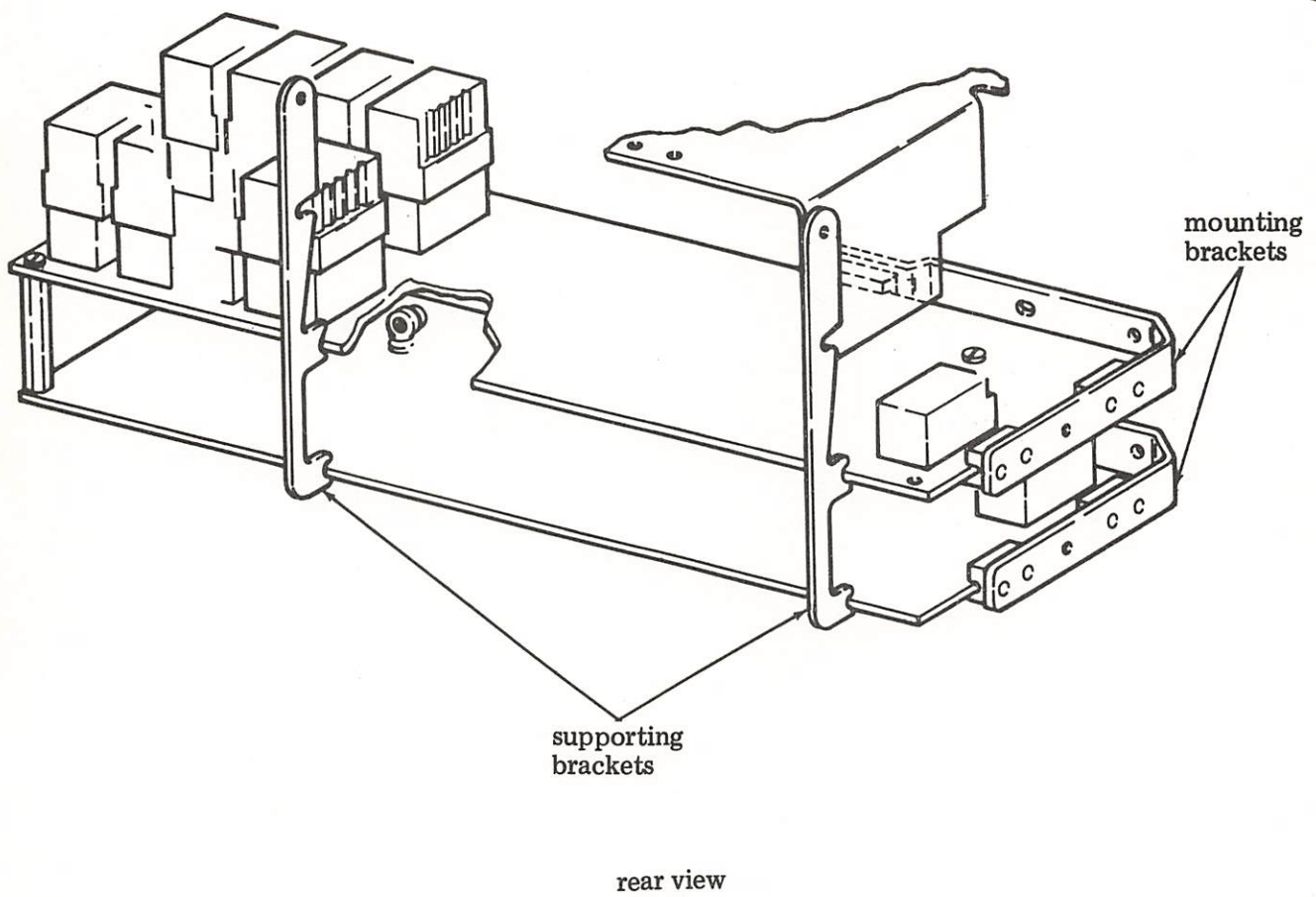

Figure 2 - Circuit Card Supporting Brackets

38 TAPE READER

DESCRIPTION AND PRINCIPLES OF OPERATION

| CONTENTS | PAGE |
|------------------------------------------|------|
| 1. GENERAL | 1 |
| 2. DESCRIPTION | 1 |
| TECHNICAL DATA | 1 |
| 3. PRINCIPLES OF OPERATION | 2 |
| A. Tape Lid Mechanism | 3 |
| B. Control Mechanism | 3 |
| C. Distributor Trip Mechanism | 3 |
| D. Feed Magnet Mechanism | 3 |
| E. Sensing Pin Guide Mechanism | 5 |
| F. Contact Block Mechanism | 5 |
| G. Tape Feed Mechanism | 5 |
| H. Upstop Mechanism | 8 |
| 4. FEATURES | 8 |
| A. Freewheeling Mechanism | 8 |
| B. Tight-Tape Mechanism | 8 |
| C. Tape-Out Mechanism | 9 |
| D. Start Position | 9 |
| E. Step Position | 9 |
| F. On Position | 10 |
| G. Stop Position | 10 |
| H. Free Position | 10 |

2. DESCRIPTION

2.01 The reader basically consists of a tape sensing and feeding mechanism driven by an electromagnet. Also included are the parallel output contacts, tight-tape, tape-out, and start-stop contacts. Current and voltage rectification is provided by the reader power pack which is mounted on the electrical service unit.

2.02 The signal set up in the parallel output contacts is distributed by the keyboard distributor which is also common to the answer-back. This keyboard distributor is tripped by means of a separate electromagnet mechanism. The electromagnet in the reader is pulsed from the keyboard distributor by means of a contact which is operated by the clutch trip lever.

TECHNICAL DATA

2.03 Dimensions and Weight (approximate)

Tape Reader

Width 3-1/2 inches
 Depth 4 inches
 Height 3-1/2 inches
 Weight 2 pounds

Reader Power Pack

Width 6-1/4 inches
 Depth 2-1/2 inches
 Height 2-3/4 inches
 Weight 1 pound

1. GENERAL

1.01 This section provides the description and principles of operation for the 38 tape reader. The reader is an 8-level electro-mechanical device which senses and transmits coded intelligence perforated in paper tape.

1.02 All references to left, right, front, and rear are with respect to the reader being viewed in its normal operating position. In the illustrations, fixed pivot points are shown in solid black; floating points, those mounted on parts that move, are crosshatched.

2.04 Environmental Characteristics

This equipment is intended to be operated in a room environment within the temperature range of 40°F to 110°F. Serious damage to it could result if this range is exceeded. In this connection, particular caution should be exercised in using acoustical or other enclosures.

3.03 The power pack provides current rectification for the reader mechanism. The power pack is mounted on the electrical service unit and is physically connected to the reader by means of a cable assembly.

3.04 The distributor trip mechanism receives the parallel output from the reader mechanism and converts it to serial stop-start signals.

A. Tape Lid Mechanism

3.05 When the tape lid latch handle is moved to the right, the spring-biased tape lid swings open. The two locating pins guide the tape as it travels across the top of the plate (Figure 2).

B. Control Mechanism

3.06 There are five positions in the control mechanism (Figure 3): START, STEP, ON, STOP, and FREE. When the control lever is moved to the START position, the spring-biased start contact wires will be positioned on the start contact. Since the start contact wires and the start contact are wired in series with the distributor clutch trip coil in the typing unit, the coil energizes and releases the tape reader trip lever (Figure 4).

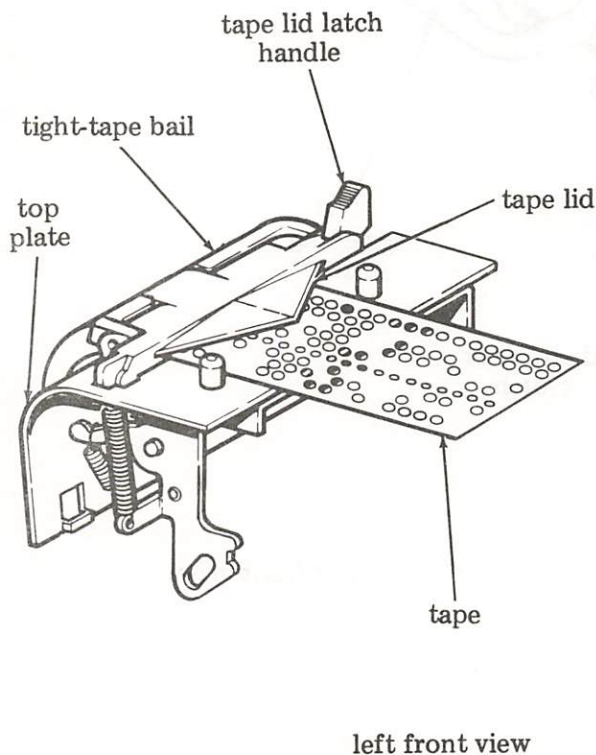

Figure 2 - Tape Lid Mechanism

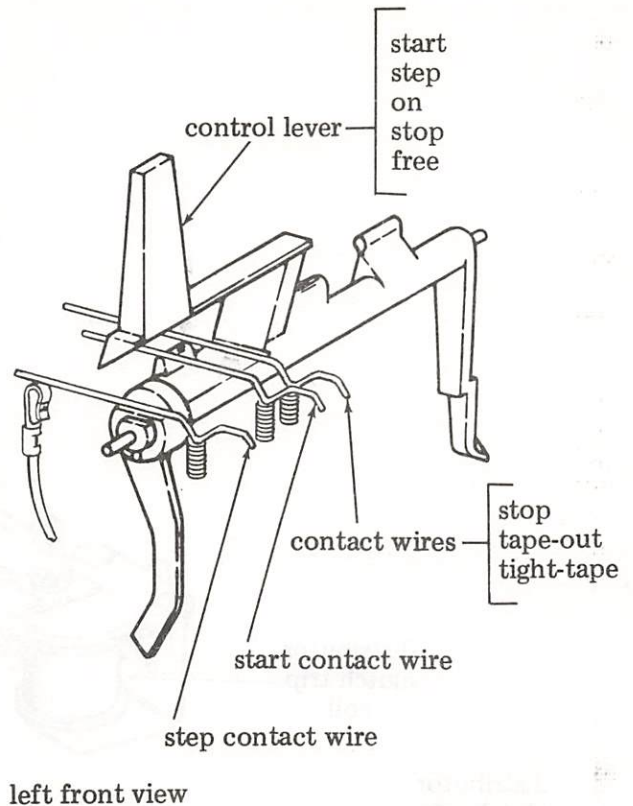

Figure 3 - Control Mechanism

C. Distributor Trip Mechanism

3.07 When the tape reader trip lever is released, it performs two functions; it closes the tape reader feed magnet contact assembly and it trips the distributor clutch (Figure 4).

3.08 The reader feed magnet assembly is closed by an insulator on the back of the tape reader trip lever. During its travel, the projection on the tape reader trip lever will rotate the distributor clutch stop bail. This motion is transferred to the distributor clutch trip lever which will move away from the shoe lever on the distributor clutch. This allows the distributor clutch to engage and begin its cycle.

D. Feed Magnet Mechanism

3.09 When the feed magnet contacts (on the distributor trip mechanism) close, the feed magnet coil in the reader mechanism is activated. The now energized feed magnet coil attracts the armature (Figure 5). As the armature is attracted to the coil it raises the armature extensions. Fastened to the ends of these armature extensions is a sensing pin guide.

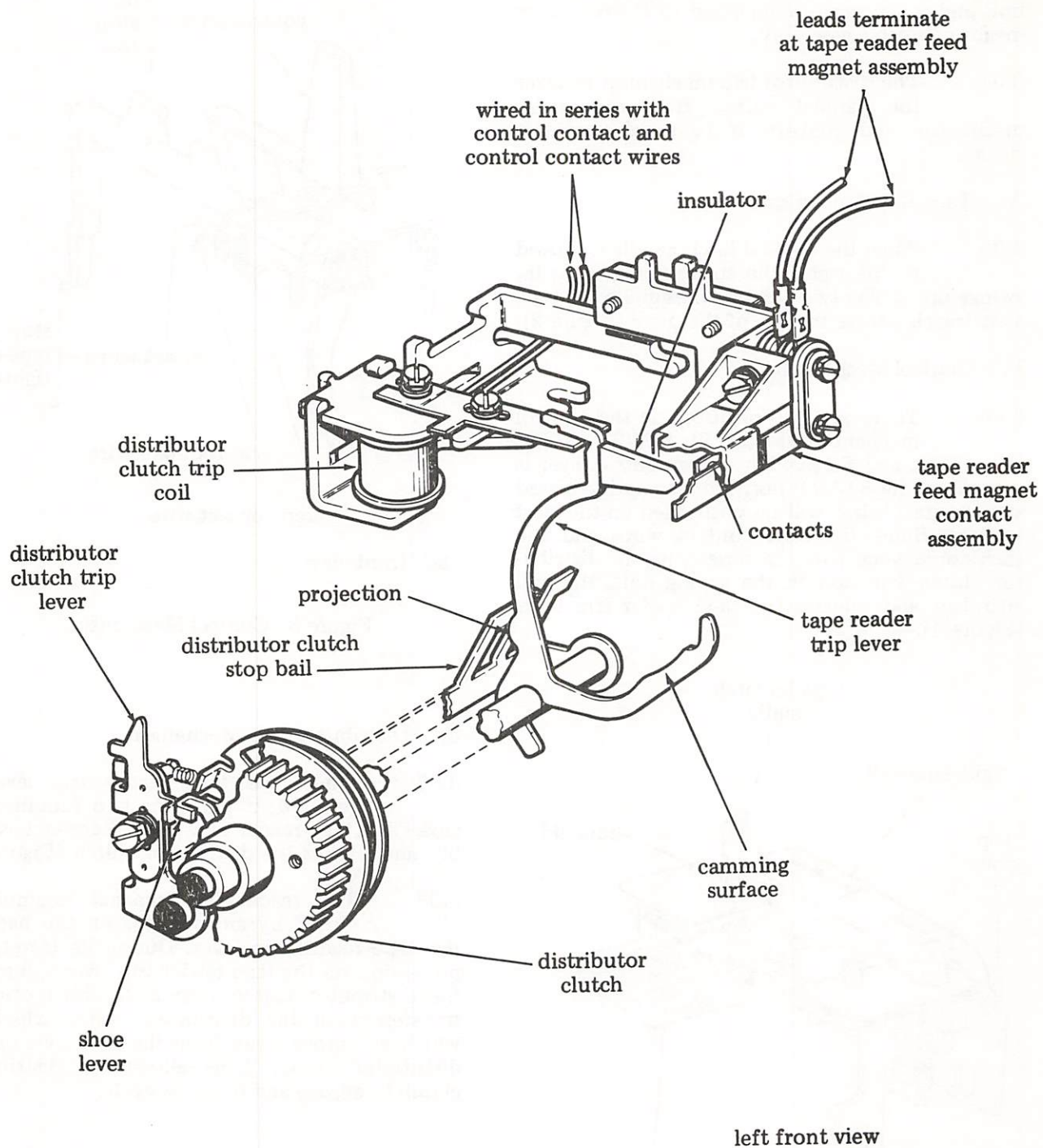

Figure 4 - Distributor Trip Mechanism

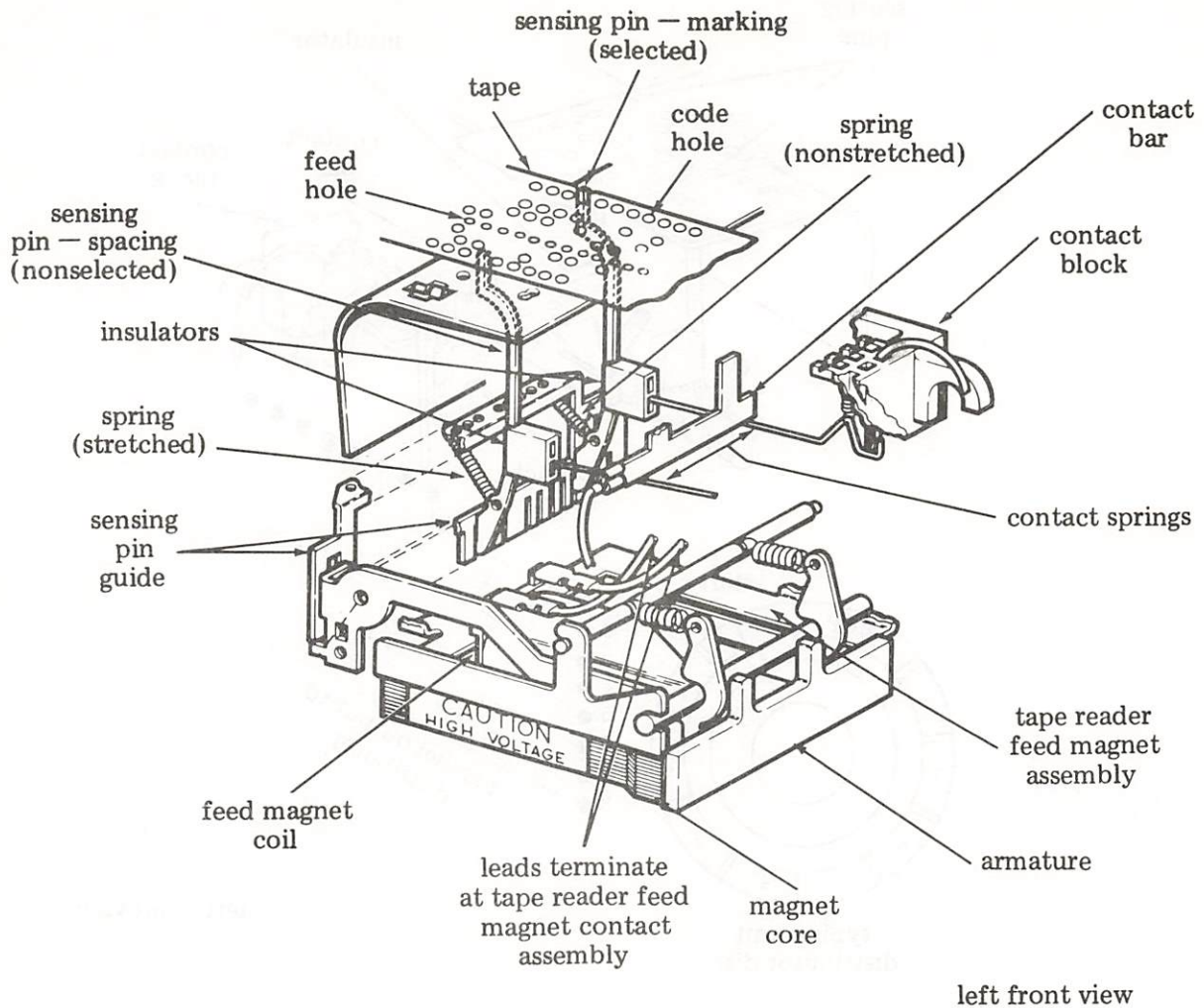

Figure 5 - Feed Magnet and Sensing Mechanisms

E. Sensing Pin Guide Mechanism

3.10 As the sensing pin guide travels upward, it carries with it eight spring-biased pins that are used to sense the perforations in the tape. Where a hole exists in the tape the sensing pin will continue to travel upward; if there is no hole in the tape the sensing pin will be blocked.

F. Contact Block Mechanism

3.11 There are insulators attached to each of the eight sensing pins which are used to hold the contact springs down and away from the contact bar (Figure 6). These contact springs are connected in parallel to corresponding segments on the distributor disc in the typing unit. If a sensing pin finds a hole in the tape its upward movement will allow its contact spring to come into contact with the contact bar (marking). If

there is no hole in the tape, the sensing pin will not move upward and its contact spring will not come in contact with the contact bar (spacing).

G. Tape Feed Mechanism

3.12 The tape feeding cycle begins when the feed magnet attracts the armature as described in 3.09. The right armature extension has a feed pawl attached to it. When the armature extensions rise, the feed pawl will engage a tooth on the feed ratchet to which the feed wheel is connected (Figure 7). The feed pawl will remain in its raised position until the actions are initiated and take place.

- (a) Hold the control lever in the START position to keep the distributor clutch trip coil energized.

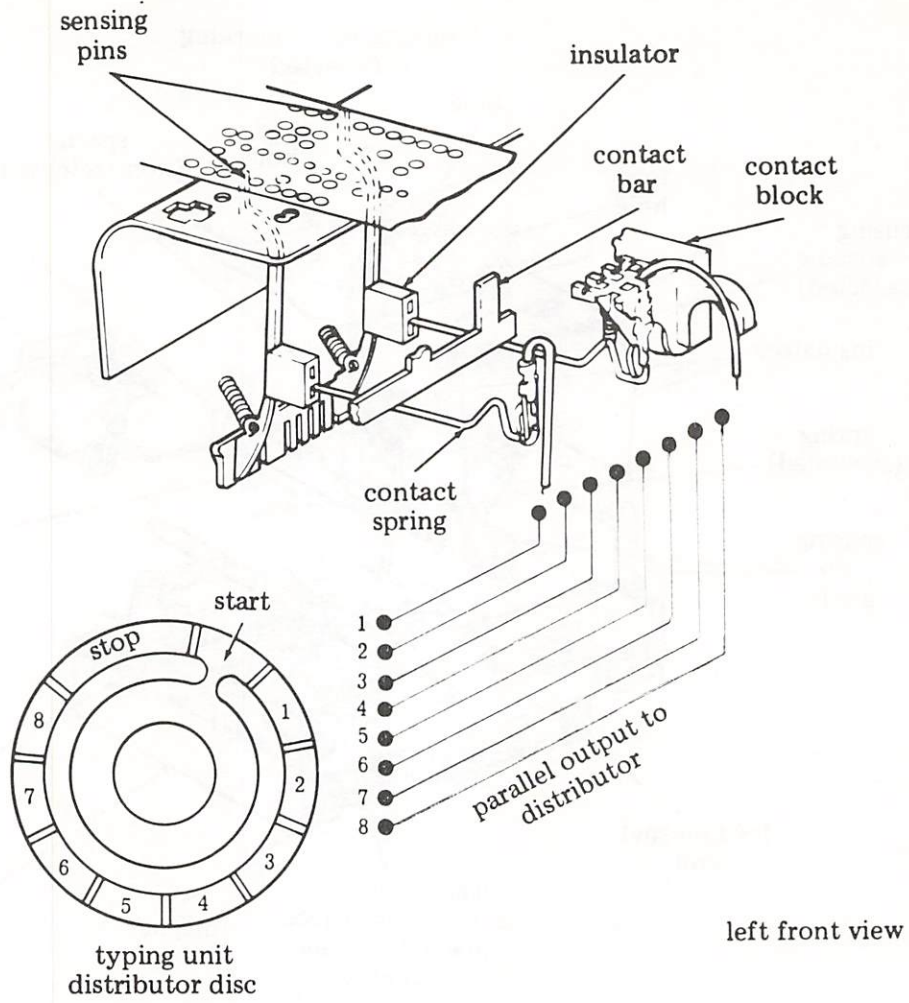

Figure 6 - Contact Block Mechanism

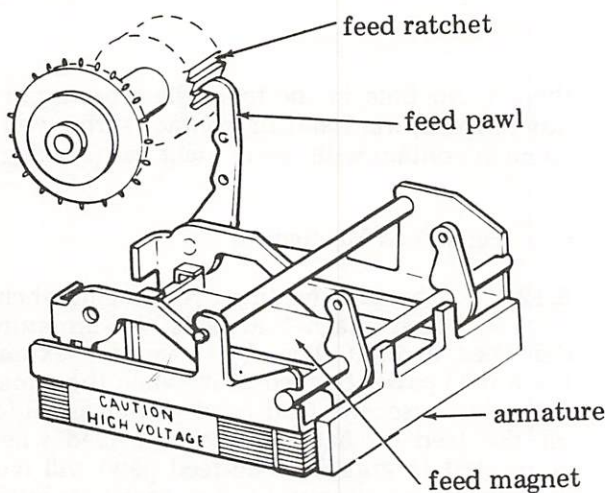

Figure 7 - Feed Pawl Engagement

- (b) Near the beginning of the stop pulse, a roller on the distributor shaft assembly engages the camming surface on the reader trip lever. This action momentarily causes the reader trip lever to release the tension on the trip coil armature extension (Figure 8).
- (c) As the reader trip lever moves away from the armature extension, the reader trip lever extension momentarily opens the feed magnet contacts causing the feed magnet in the reader mechanism to become de-energized (Figure 9).
- (d) With the feed magnet de-energized, the armature extensions drop. The sensing pin guide and the sensing pins will start to drop (Figure 10) and clear the tape just before the feed pawl advances the feed ratchet (Figure 11).

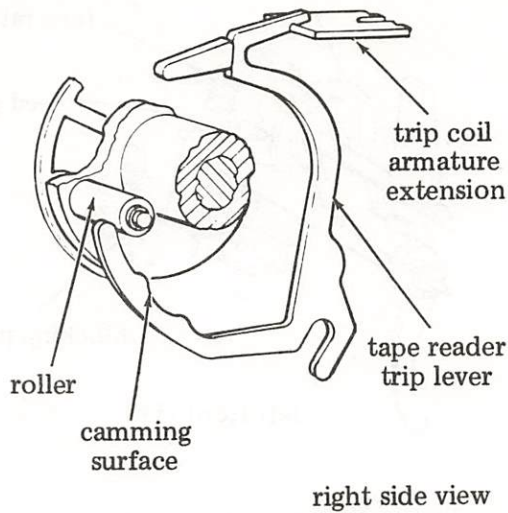

Figure 8 - Tape Reader Trip Lever

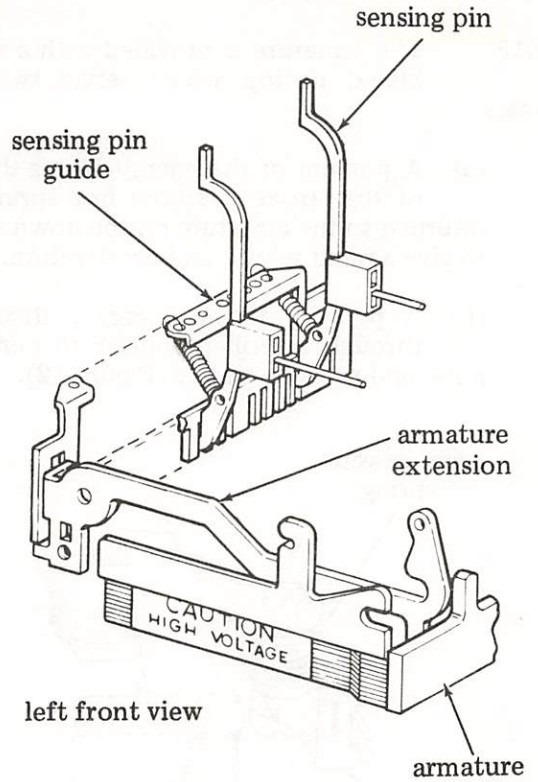

Figure 10 - Sensing Pin Guide

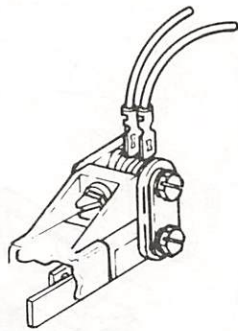

Figure 9 - Feed Magnet Contacts

3.13 Associated with the feed ratchet are a detent lever and a blocking pawl. The detent lever, with its circular surface engaging the feed ratchet teeth, holds the feed ratchet and feed wheel in its correct position during sensing (Figure 11).

3.14 The blocking pawl, which rides a post on the feed pawl, is lowered into engagement with a feed ratchet tooth during the feed stroke. This is to prevent excessive overthrow of the feed wheel, without the use of a heavy detent spring. During the upstroke of the armature extensions, the blocking pawl is rotated out of engagement with the tooth by the post on the feed pawl (Figure 11).

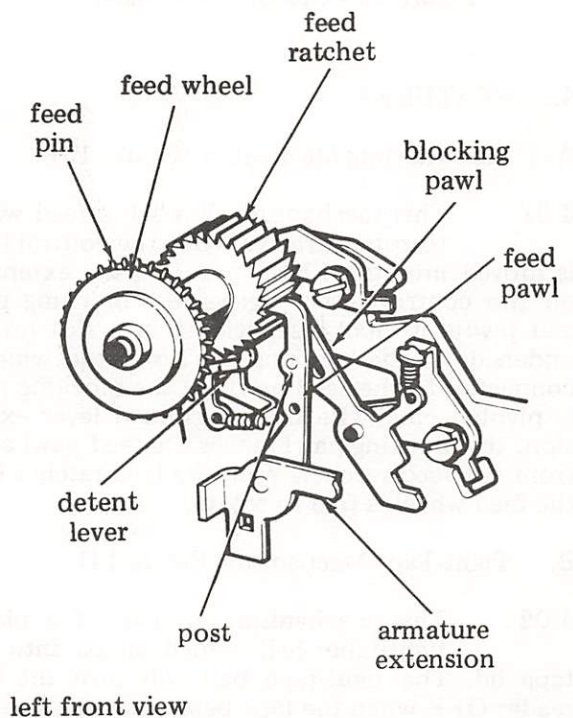

Figure 11 - Tape Feed Mechanism

H. Upstop Mechanism

3.15 The armature is provided with a spring-biased upstop which serves two purposes.

- (a) A portion of the energy during the end of the stroke is stored in a spring and returned to the armature on the down stroke to give a rapid release and acceleration.
- (b) A portion of the energy is dissipated through a resilient buffer to minimize noise and metallic clatter (Figure 12).

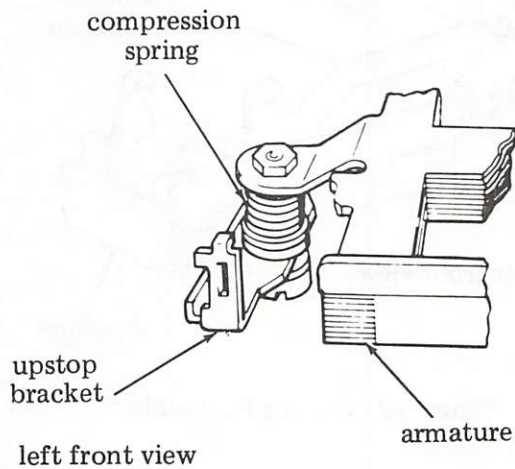

Figure 12 - Upstop Mechanism

4. FEATURES

A. Freewheeling Mechanism (Figure 13)

4.01 This mechanism allows the feed wheel to rotate freely. When the control lever is moved into the FREE position, the extension on the control lever engages the blocking pawl and pivots it clockwise. Riding in a slot on the underside of the blocking pawl is a stud which is connected to the feed pawl. As the blocking pawl is pivoted clockwise by the control lever extension, the blocking pawl moves the feed pawl away from the feed ratchet. With the feed ratchet free, the feed wheel is free to rotate.

B. Tight-Tape Mechanism (Figure 14)

4.02 This mechanism consists of a plastic tight-tape bail which snaps into the tape lid. The tight-tape bail will turn the tape reader OFF when the tape becomes taut. The bail has an extension on it which projects through the top plate. This extension rides on a spring-biased tight-tape lever. As the tape becomes taut the bail

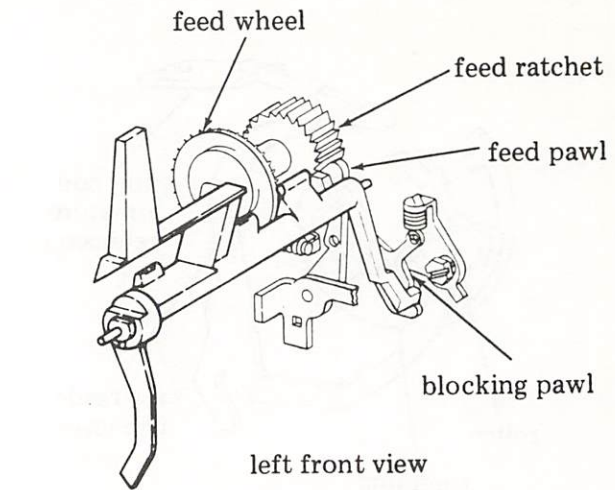

Figure 13 - Freewheeling Mechanism

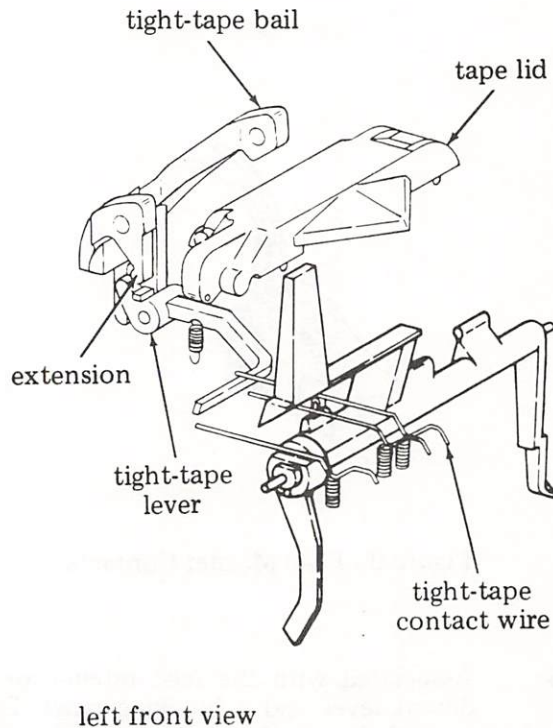

Figure 14 - Tight-Tape Mechanism

will be lifted, the bail extension will rotate causing the tight-tape lever to rotate also. As the tight-tape lever rotates, its pivoting action will lift the tight-tape contact wires away from the contact terminal, breaking the current path. With the circuit broken, the reader will stop.

C. Tape-Out Mechanism (Figure 15)

4.03 This mechanism will stop the reader when it runs out of tape. There is a tape-out pin that protrudes above the surface of the top plate. As long as there is tape in the reader, this pin will be kept depressed. When the tape runs out, the spring bias on the tape-out pin causes it to move upward. The insulated extension on the tape-out pin lifts the tape-out contact wires away from the contact terminal, breaking the current path.

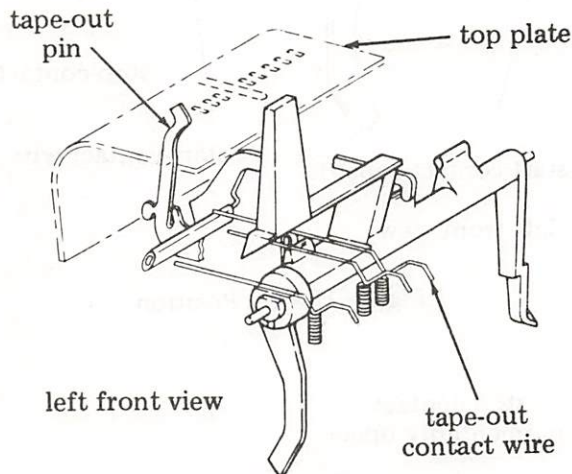
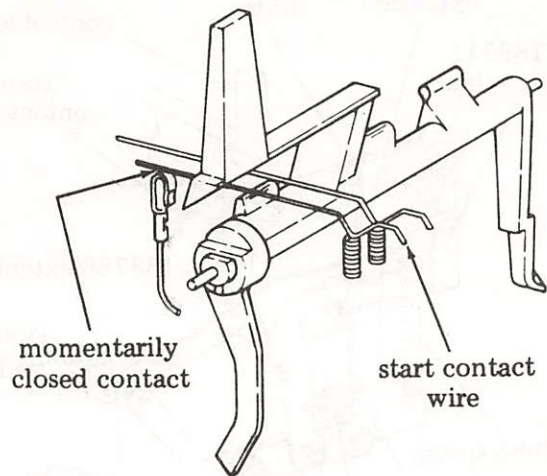

Figure 15 - Tape-Out Mechanism

D. Start Position (Figure 16)

4.04 When the control lever is placed in the START position the following will take place:

- (a) The start contact wires momentarily close.
- (b) After closing momentarily, the start-contact wires are lifted away from the start contact due to the detent action of the control lever.
- (c) The momentarily closing of the start-contact wires energizes the relay and the two normally open contacts associated with the relay.
- (d) The first relay contact closes a holding circuit.
- (e) The second relay contact, if there is tape in the reader and it is not taut, closes the circuit to the distributor clutch. The distributor clutch will then be tripped as explained in 3.07.



left front view

Figure 16 - Start Position

E. Step Position (Figure 17)

4.05 When the control lever is placed in the STEP position the following will happen:

- (a) The control lever extension will cause the spring-biased primary latch to move away from the tie link.
- (b) The spring-biased tie link will drop down between the secondary latch and the primary latch.
- (c) As the tie link drops, it will cause the attached lever to also drop. This will allow the step-contact wire to touch the step contact.
- (d) When the step-contact wire touches the step contact, an electrical path to the reader trip magnet is completed.
- (e) When the reader trip armature attracts, the distributor clutch trips and allows a contact closure to energize the reader magnet.
- (f) The upward movement of the reader armature will sense the character in the tape and then advance the tape one character position. This same movement will force the attached lever (the same lever that is attached to the tie link) upward causing the step-contact wire to move away from the step contact. This breaks the circuit to the reader trip magnet.

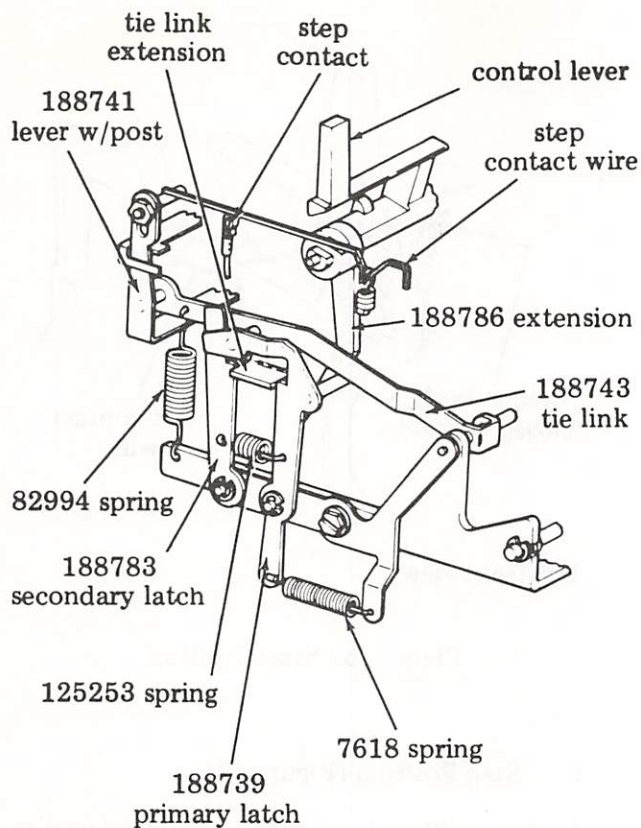

left front view

Figure 17 - Step Position

F. On Position (Figure 18)

4.06 When the control lever is placed in the ON position, the start contact is open and the stop contact is closed. The reader will respond to a remote reader start signal and turn on automatically. The remote signal will close a contact in the typing unit function area which will complete an electrical path to the distributor.

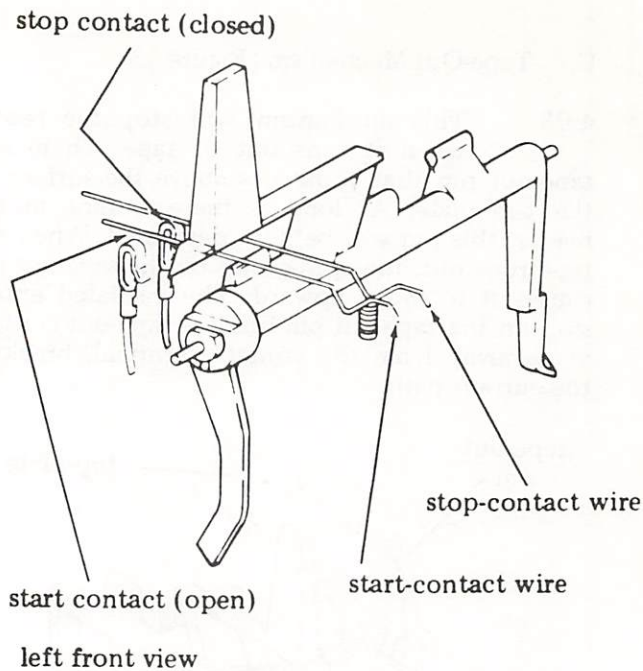

Figure 18 - On Position

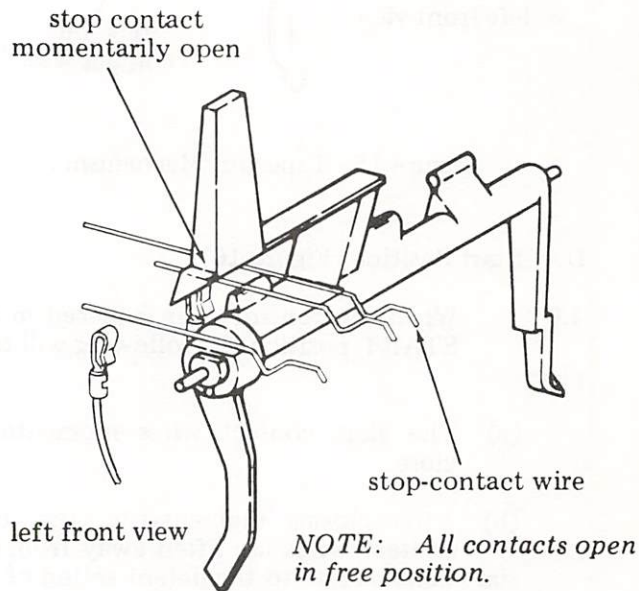

Figure 19 - Stop Position and Free Position

G. Stop Position (Figure 19)

4.07 When the control lever is placed in the STOP position, the stop-contact wires are momentarily removed from the stop contact. This will de-energize the reader relay, opening two relay contacts. One of these contacts will open the reader trip magnet circuit. This will de-energize the trip magnet causing the reader to stop.

H. Free Position (Figure 19)

4.08 When the control lever is placed in the FREE position the start and stop contacts are open. The tape reader will not respond to a remote reader start signal.

38 READER
 LUBRICATION

| CONTENTS | PAGE |
|------------------------------------------|------|
| 1. GENERAL | 1 |
| 2. BASIC UNIT | 2 |
| Armature shaft | 4 |
| Clutch trip area | 6 |
| Control mechanism | 5 |
| Distributor clutch trip magnet | 7 |
| Feed pawl mechanism | 5 |
| Feed wheel | 4 |
| Reader feed magnet contact | 7 |
| Reader trip lever | 8 |
| Single step mechanism | 9 |
| Tape lid mechanism | 6 |
| Tape reader | 2 |
| Tape reader mechanism | 3 |
| Tight-tape mechanism | 4 |

1. GENERAL

1.01 This section provides lubrication procedures for the Model 38 Reader. It is reissued to change the lubrication interval in 1.04. To remove the reader as a unit from the teletypewriter, refer to Section 574-400-702TC.

1.02 Lubrication of the reader is presented by mechanisms. Photographs show numbered callouts which correspond to paragraphs containing line drawings. These line drawings show the specific points of each mechanism to be lubricated.

1.03 Lubricate the reader thoroughly. Apply oil to points where it will adhere and not run off. Avoid overlubrication. Keep electrical contacts and wire insulations free of lubricants. In general, apply oil to locations where parts rub, slide, or move with respect to each other.

1.04 Lubricate the reader before placing it in service, and just before placing it in storage. After about 100 to 200 operating hours, relubricate reader. Thereafter, lubricate every 750 operating hours or six months, whichever occurs first.

1.05 The following symbols and their meaning apply to the lubrication points in each paragraph:

| <u>SYMBOL</u> | <u>MEANING</u> |
|---------------|----------------------------------------------------|
| D | Dry — no lubricant permitted |
| G | Grease — apply KS7471 grease as instructed |
| L | Lubriplate — apply 108805 Lubriplate as instructed |
| O | Oil — apply KS7470 oil as instructed |

NOTE: Quantity of lubricant is normally given in the text associated with the mechanism.

1.06 References to front, rear, left, right, etc, are made viewing the reader from its normal operating position.

CAUTION: DISCONNECT POWER BEFORE APPLYING ANY LUBRICANT. DO NOT USE SOLVENTS TO CLEAN PLASTIC PARTS OR PROTECTIVE FINISHES. USE A SOFT DRY CLOTH. IF NECESSARY, USE A SOFT DAMP CLOTH WITH MILD DETERGENT, THEN RINSE AND BUFF WITH A SOFT DRY CLOTH.

2. BASIC UNIT

2.01 Tape Reader

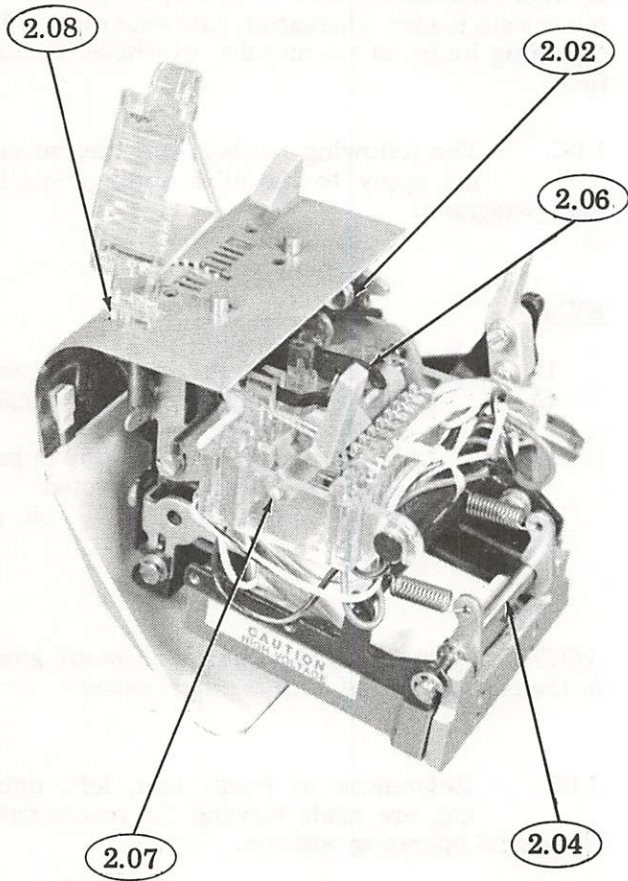

left front view

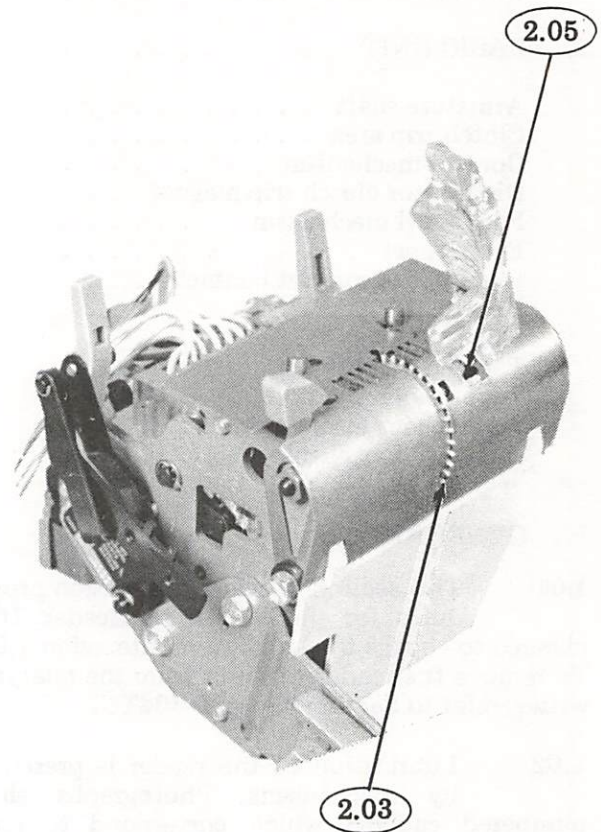

right rear view

2.02 Tape Reader Mechanism

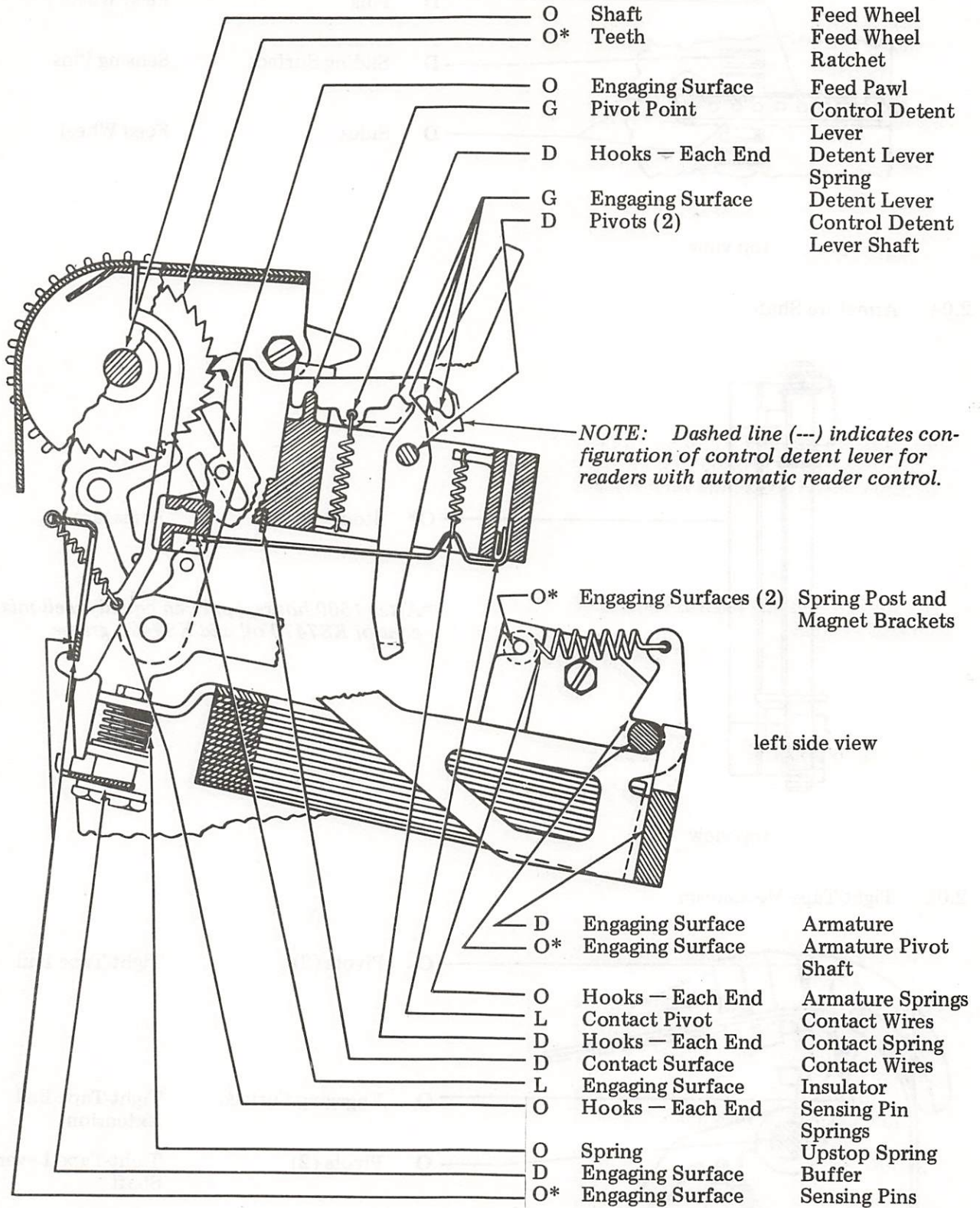

**After 1500 hours, apply an equally well-mixed coat of KS7470 oil and KS7471 grease.*

2.03 Feed Wheel

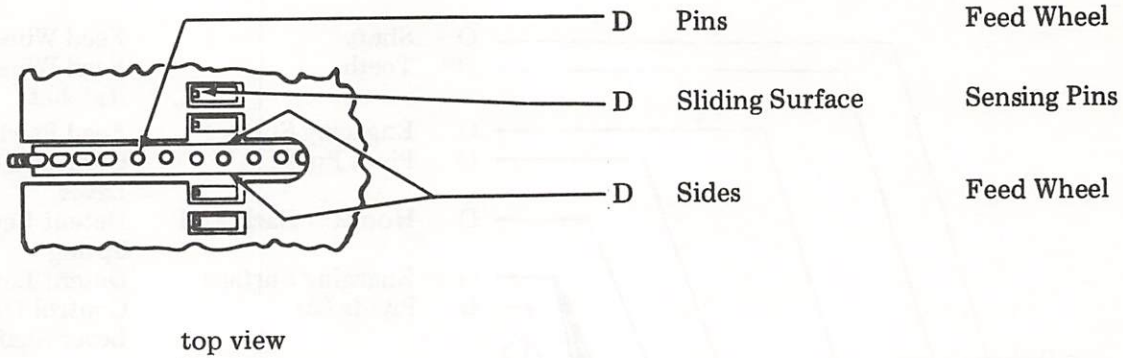

top view

2.04 Armature Shaft

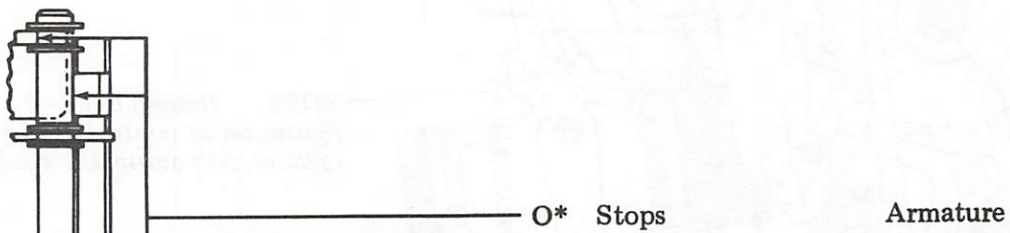

**After 1500 hours, apply an equally well-mixed coat of KS7470 oil and KS7471 grease.*

top view

2.05 Tight-Tape Mechanism

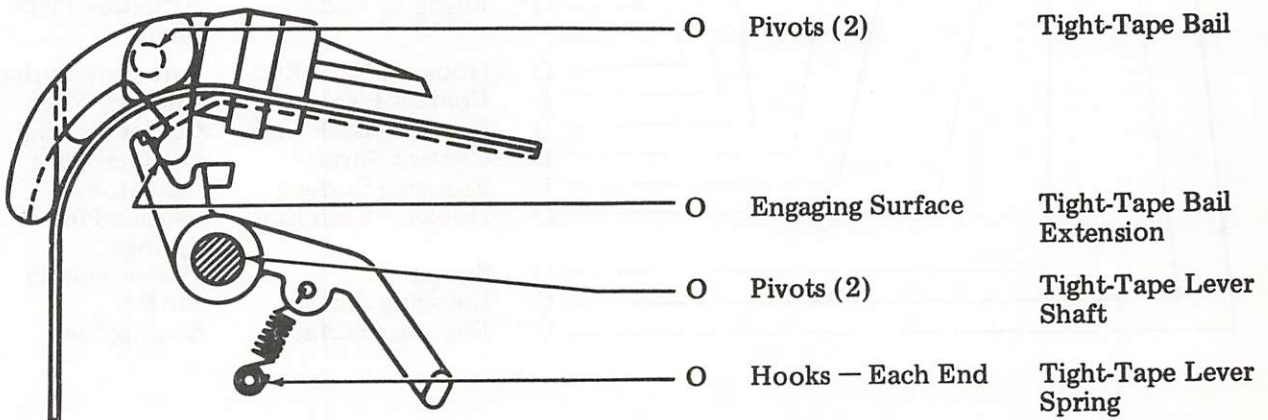

left side view

2.06 Feed Pawl Mechanism

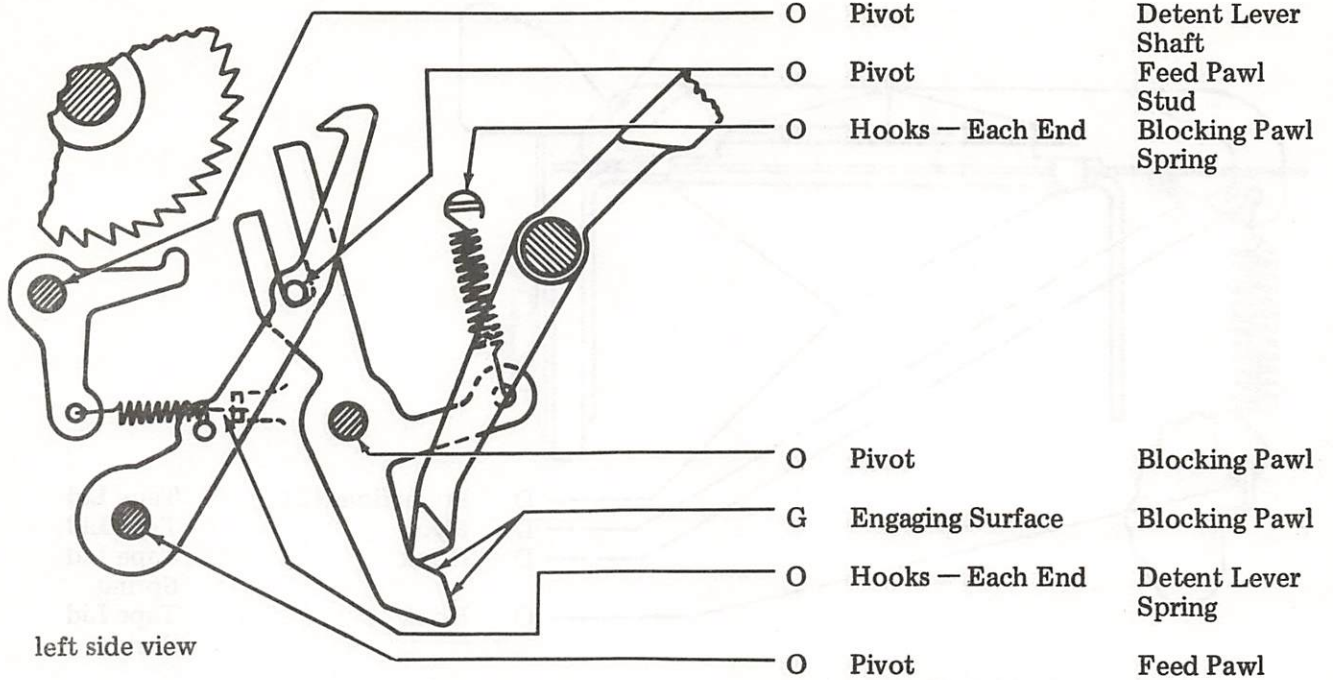

2.07 Control Mechanism

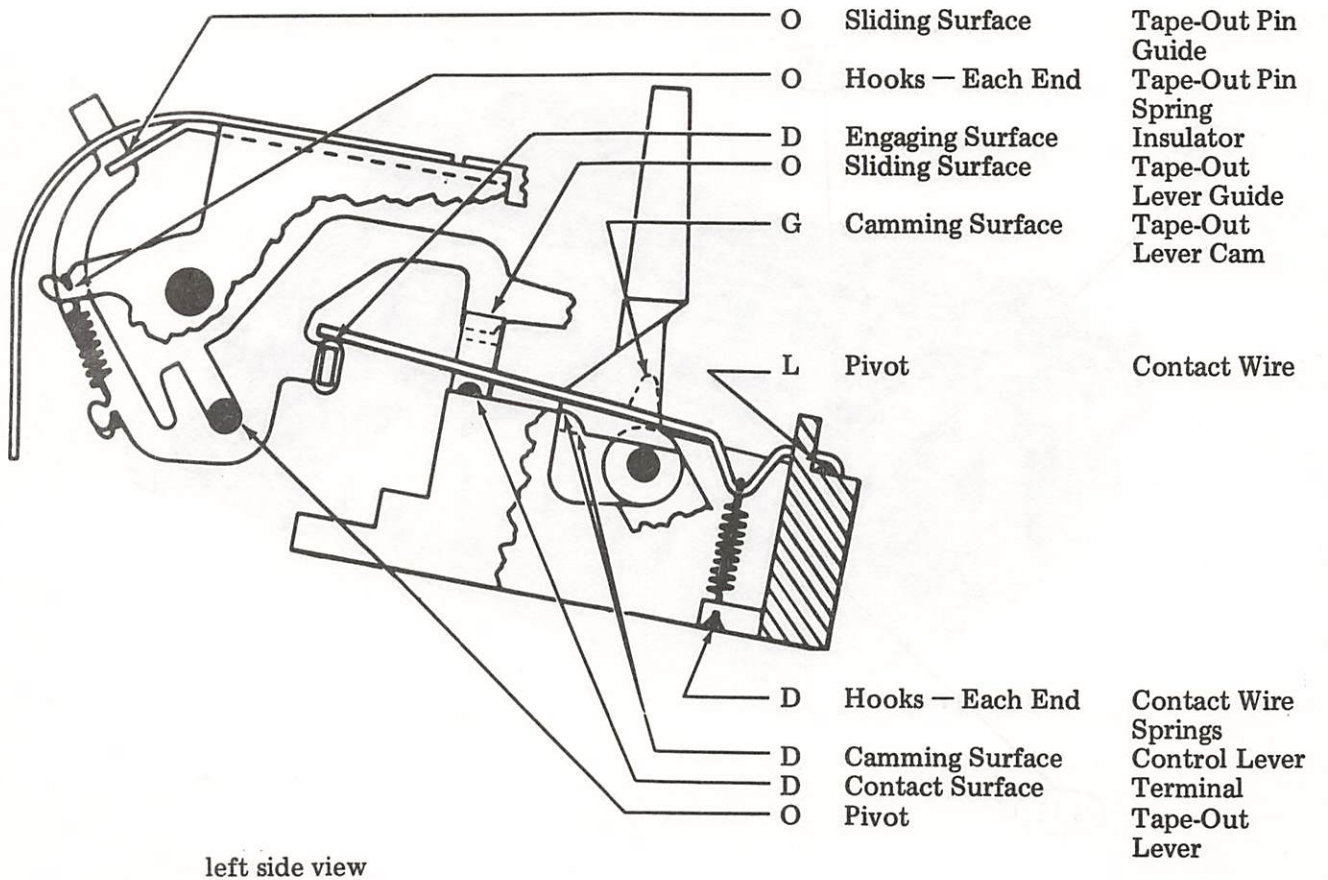

2.08 Tape Lid Mechanism

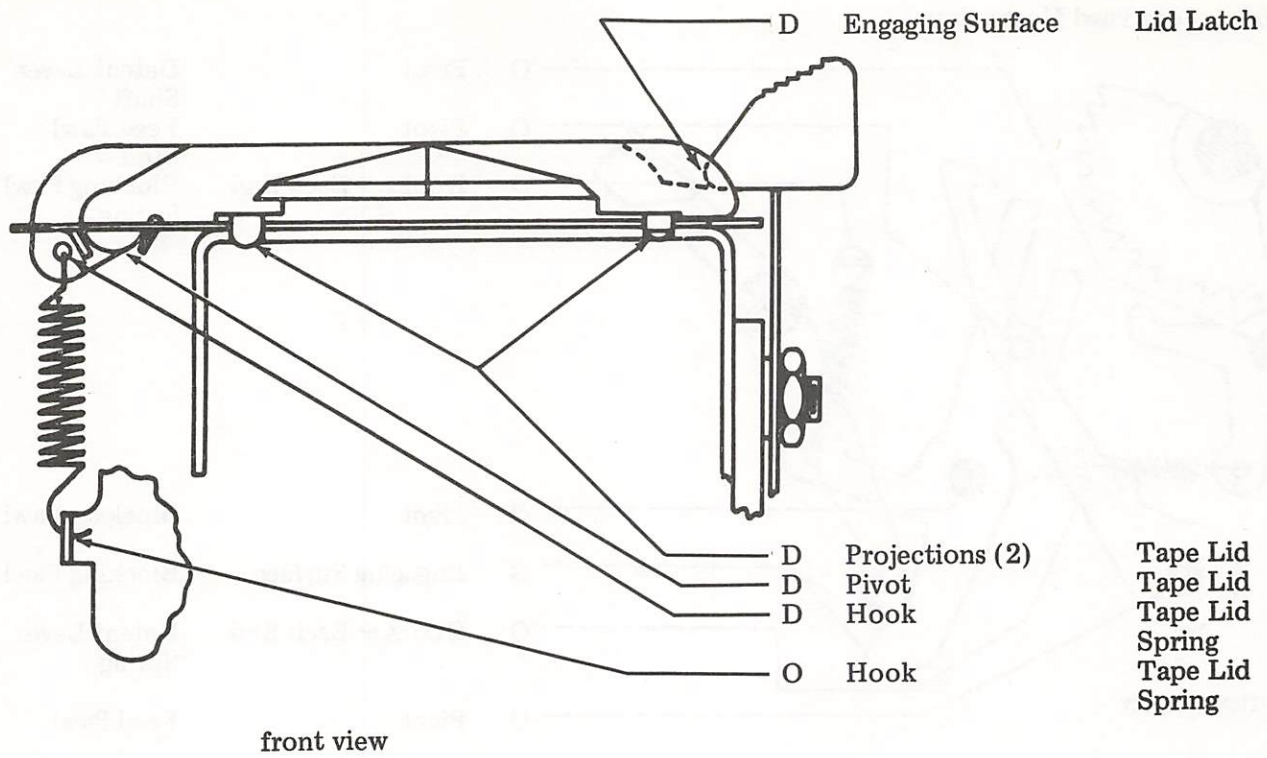

2.09 Clutch Trip Area

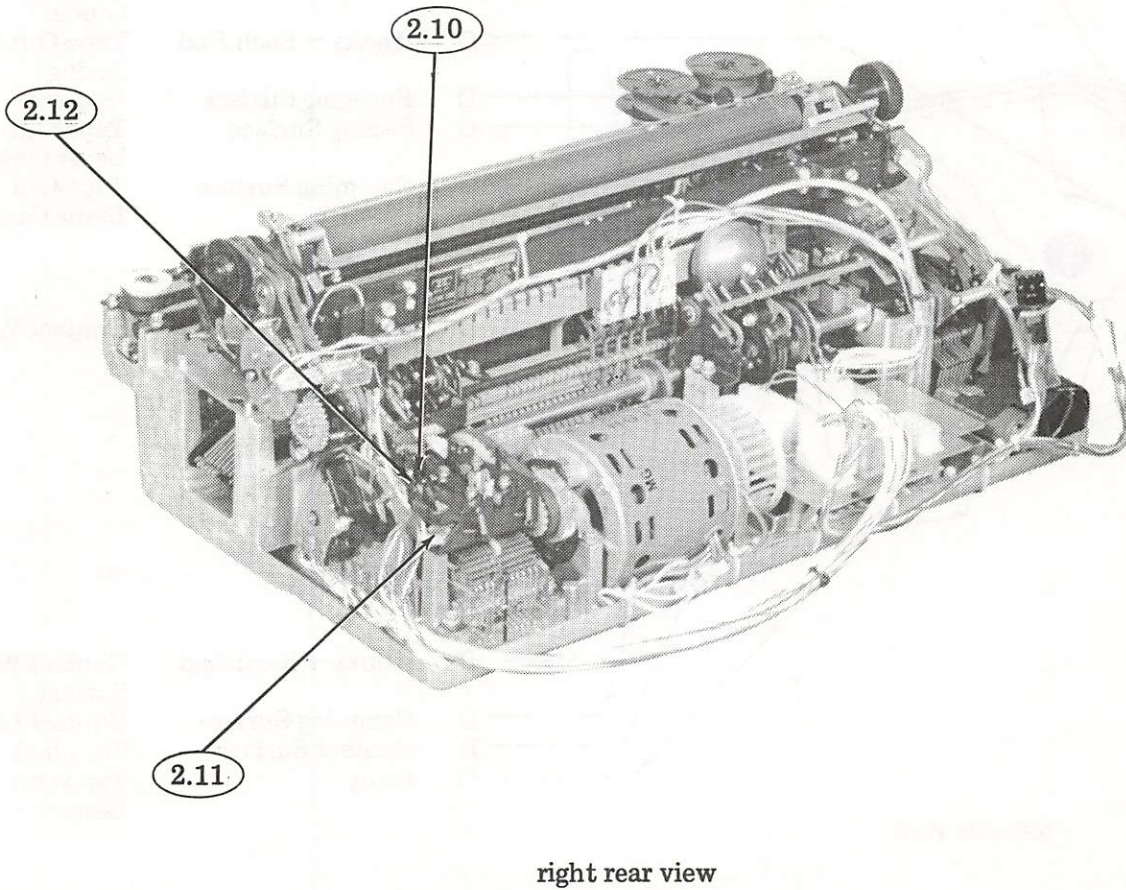

2.10 Reader Feed Magnet Contact

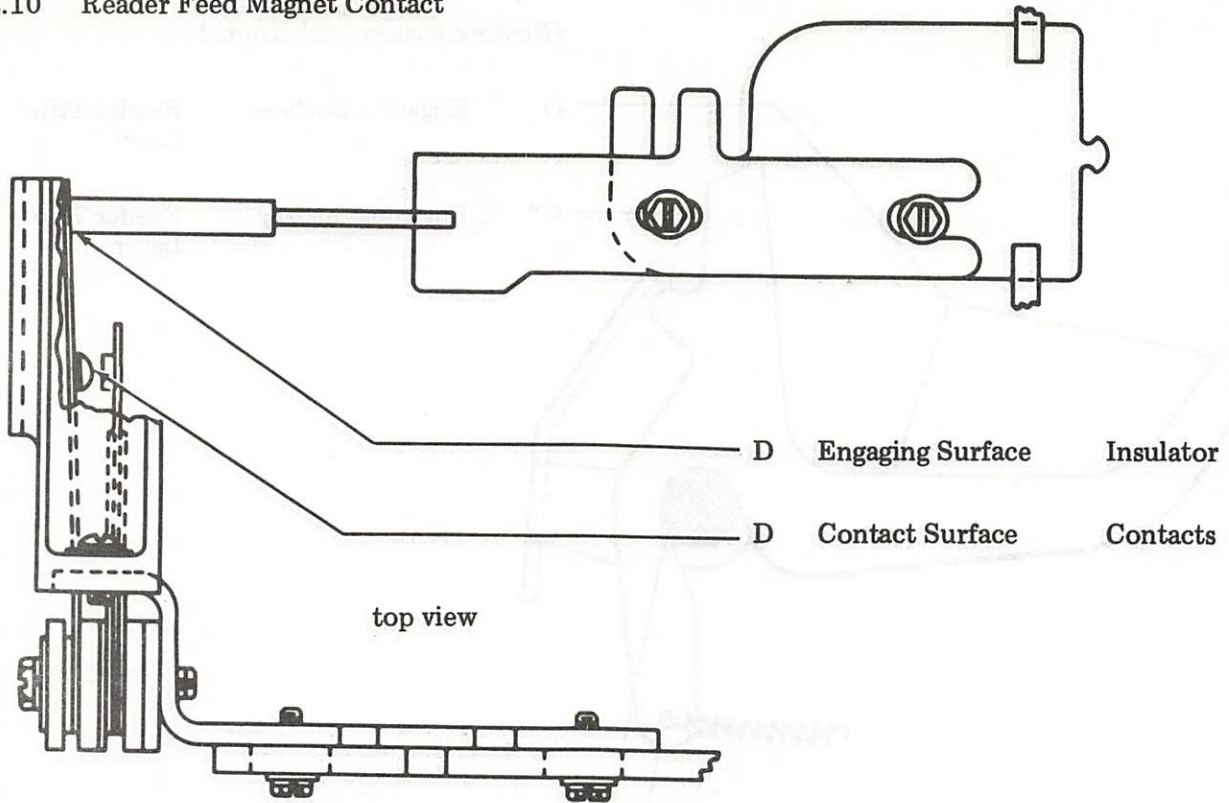

2.11 Distributor Clutch Trip Magnet

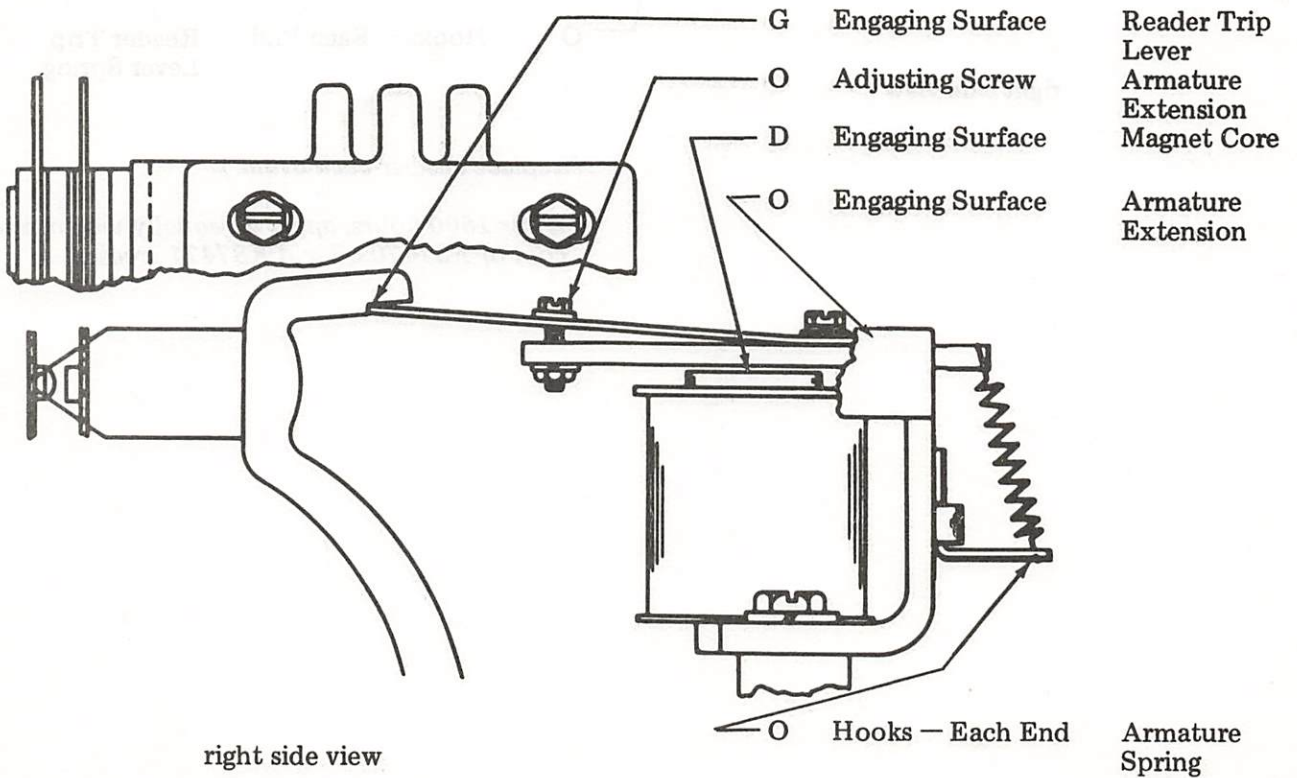

2.12 Reader Trip Lever

(Remove answer-back drum.)

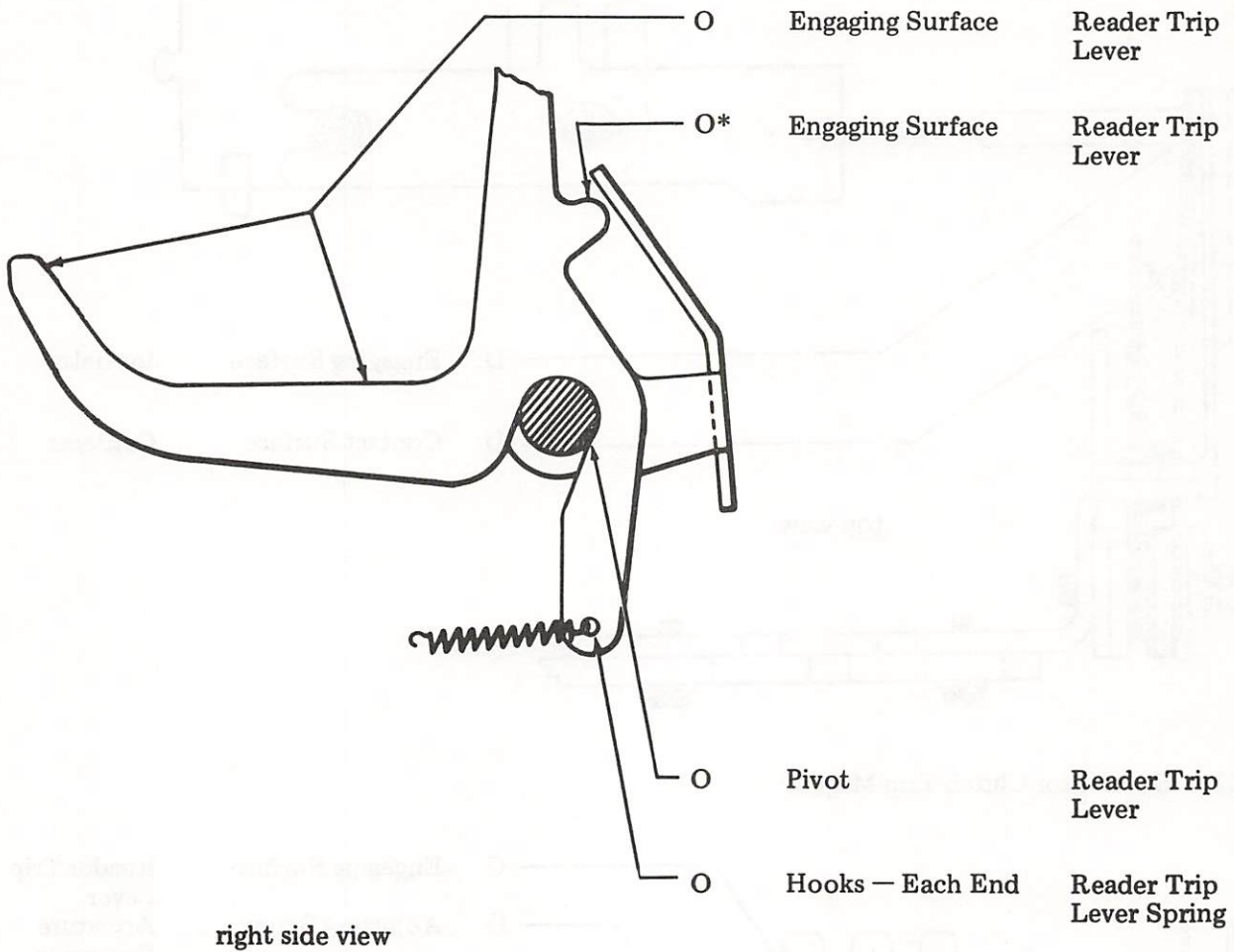

(Replace answer-back drum.)

**After 1500 hours, apply an equally well-mixed coat of KS7470 oil and KS7471 grease.*

2.13 Single Step Mechanism

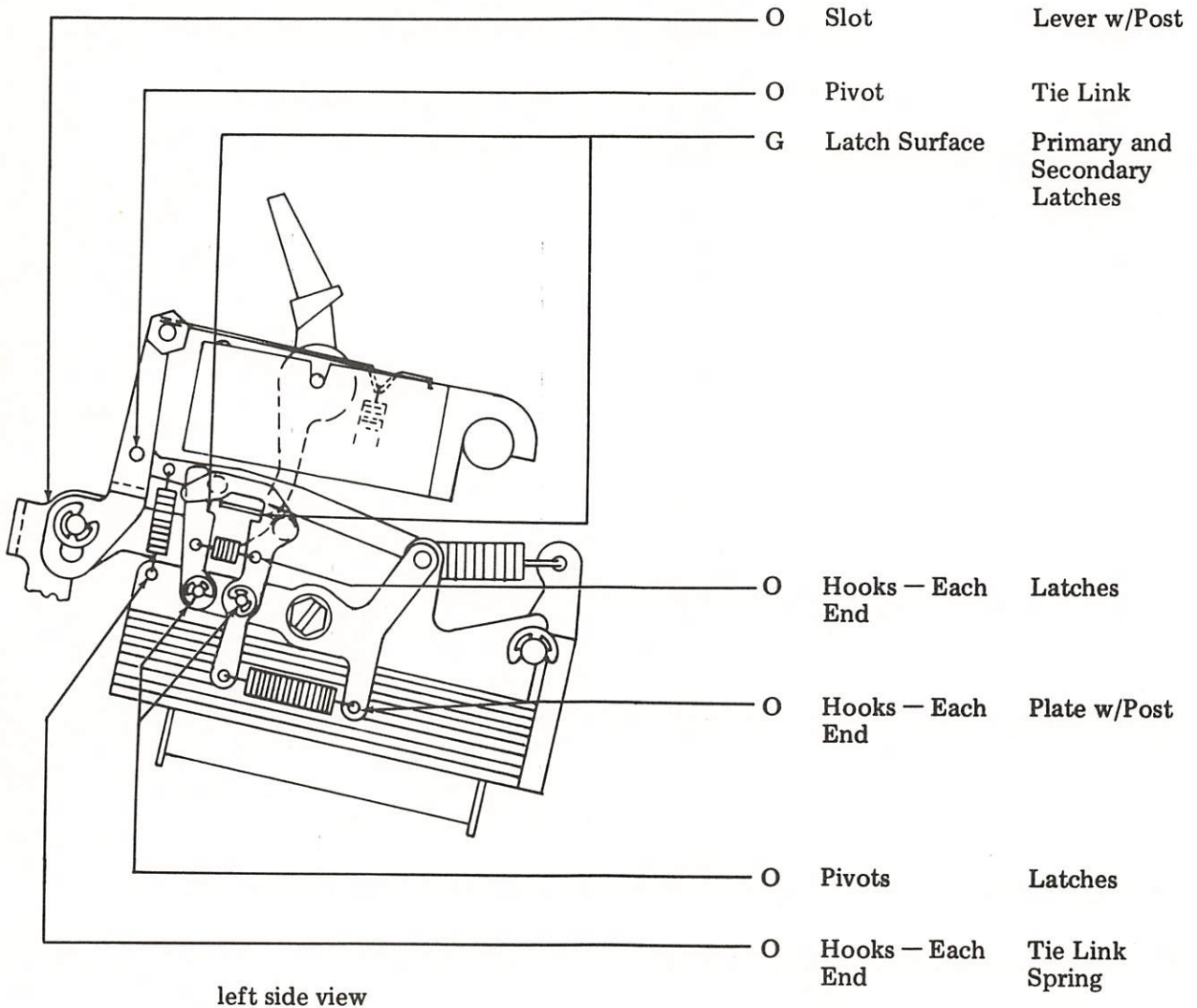

38 READER

DISASSEMBLY AND REASSEMBLY

| CONTENTS | PAGE |
|--------------------------------------------|------|
| 1. GENERAL | 1 |
| 2. READER | 1 |
| SENSING PIN MECHANISM | 1 |
| CONTACT BLOCK CABLE ASSEMBLY | 1 |
| FEED MAGNET ASSEMBLY | 1 |
| FEED WHEEL TOP PLATE ASSEMBLY | 1 |

1. GENERAL

1.01 This section provides disassembly and reassembly instructions for the 38 reader. The instructions are confined to major subassemblies only. If further reader disassembly and reassembly is required, refer to Section 574-424-800TC.

1.02 To remove the reader as a unit from the teletypewriter, refer to Section 574-400-702TC.

2. READER

SENSING PIN MECHANISM

2.01 Disassemble sensing pin mechanism (Figure 1) as follows:

- (a) Remove two screws, lockwashers, and flat washers from sensing pin guide.
- (b) Remove sensing pin mechanism from reader.

2.02 Reassemble sensing pin mechanism by reversing procedure in 2.01.

CONTACT BLOCK CABLE ASSEMBLY

2.03 Disassemble contact block cable assembly (Figure 1) as follows:

- (a) Remove nut from contact block shaft.
- (b) Slide shaft left until it clears hole in mounting plate.
- (c) Pull contact block forward until it disengages from top plate bracket mounting slots.
- (d) Remove contact block cable assembly.

2.04 Reassemble contact block cable assembly by reversing procedure in 2.03.

FEED MAGNET ASSEMBLY

2.05 Disassemble feed magnet assembly (Figure 2) as follows:

- (a) Remove sensing pin mechanism as outlined in 2.01.
- (b) Remove contact block cable assembly as outlined in 2.03.
- (c) Disconnect two push-on terminals from magnet coil.
- (d) Remove retaining ring from feed pawl stud and disengage feed pawl.
- (e) Remove three magnet bracket mounting screws.
- (f) Remove feed magnet assembly.

2.06 Reassemble feed magnet assembly by reversing procedure in 2.05.

FEED WHEEL TOP PLATE ASSEMBLY

2.07 Disassemble feed wheel top plate (Figure 2) as follows:

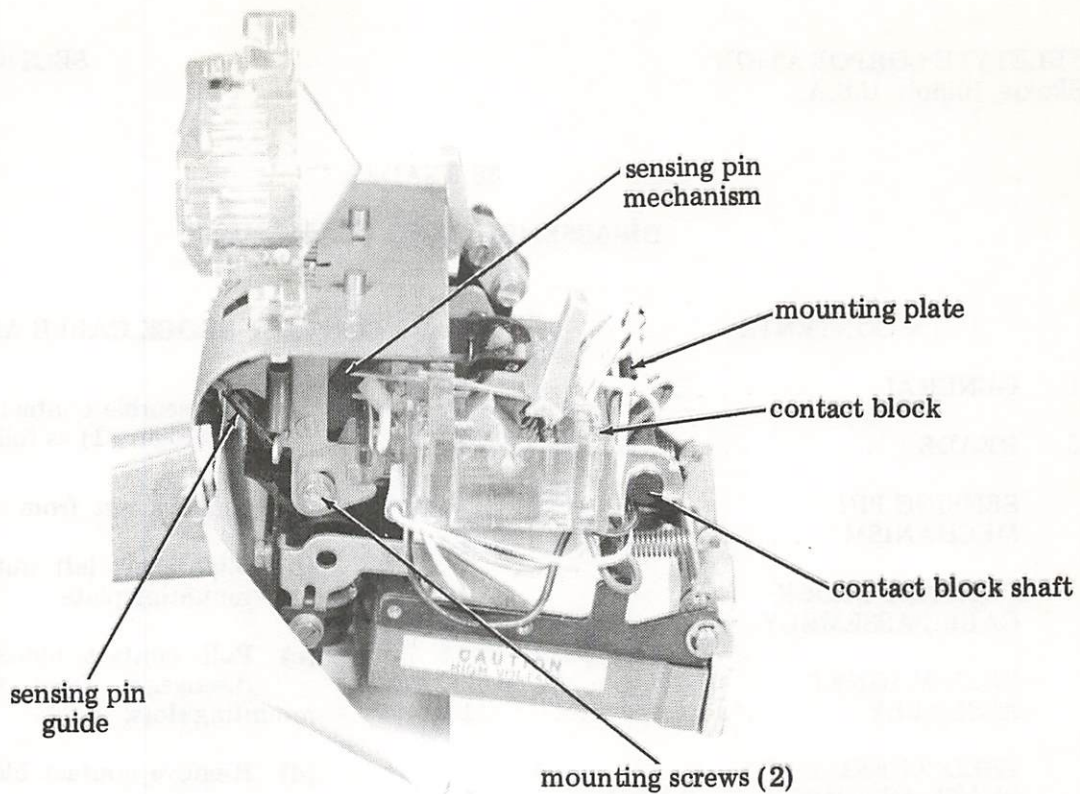

left side view

Figure 1 - Reader Sensing Pins and Contact Block Assemblies

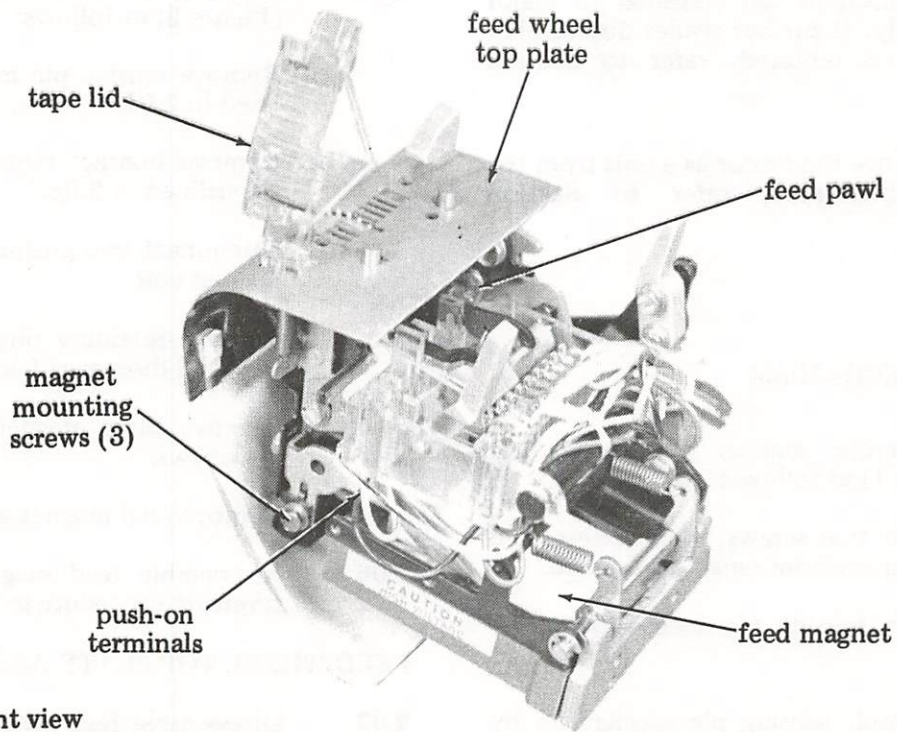

left front view

Figure 2 - Feed Magnet and Feed Wheel Top Plate Assemblies

- (a) Remove contact block cable assembly as outlined in 2.03.
- (b) Remove sensing pin mechanism as outlined in 2.01.
- (c) Remove feed magnet assembly as outlined in 2.05.

- (d) Unlatch tape lid.
- (e) Remove detent bracket mounting screw, feed wheel shaft nut, and lock-washer.
- (f) Remove feed wheel top plate assembly.

2.08 Reassemble feed wheel top plate by reversing procedure in 2.07.

38 TAPE PUNCH

DESCRIPTION AND PRINCIPLES OF OPERATION

| | CONTENTS | PAGE |
|----|---------------------------------------------------|------|
| 1. | GENERAL | 1 |
| 2. | TECHNICAL DATA | 2 |
| | DIMENSIONS AND WEIGHT | 2 |
| | TAPE SPECIFICATIONS | 2 |
| | CHAD BOX | 2 |
| | SPEED OF OPERATION | 2 |
| 3. | DESCRIPTION AND PRINCIPLES OF OPERATION | 2 |
| | DRIVE MECHANISM | 2 |
| | INTELLIGENCE TRANSFER MECHANISM | 2 |
| | TAPE FEED MECHANISM | 5 |
| | TAPE GUIDE MECHANISM | 5 |
| | PUNCH BLOCK MECHANISM | 7 |
| | BACKSPACE MECHANISM | 7 |
| 4. | CONTROL FEATURES | 7 |
| | MANUAL PUNCH | 7 |
| | AUTOMATIC PUNCH | 7 |
| 5. | VARIABLE FEATURE | 8 |

1. GENERAL

1.01 This section provides the description and principles of operation for the 38 tape punch (Figure 1). The 38 tape punch is an 8-level device which perforates paper tape accord-

ing to ASCII (American National Standard Code for Information Interchange).

1.02 The tape punch mounts to the left side of the 38 typing unit, and uses the typing unit's function shaft, selector, and codebars for its drive power and intelligence input.

1.03 The 38 tape punch is capable of operating either manually or automatically (programmable). The manual tape punch is controlled by manually operating the control lever. When switched to the ON position, the punch operates in conjunction with the associated typing unit, and will remain on, despite any on-line signal to turn it off. When manually switched to the OFF position, the punch discontinues punching tape, and remains off despite any on-line signal to turn it on.

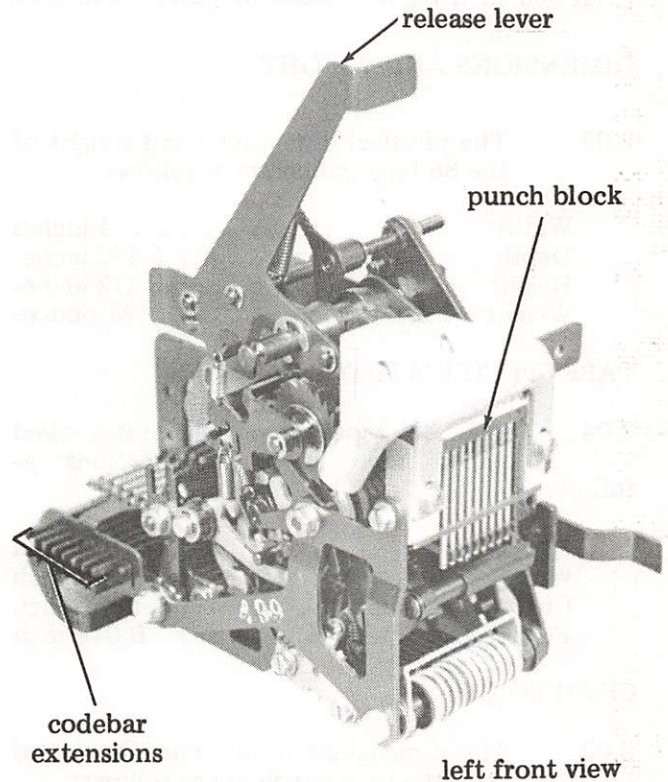

Figure 1 - 38 Tape Punch

1.04 The automatic tape punch operates both manually, with the control lever, and automatically, with on-line signals. While the punch is on, it can be turned off with either the control lever, or from an on-line signal. Likewise, if the punch is off, it can be turned on with either the control lever, or from an on-line signal.

1.05 References to right or left, front or rear, consider the tape punch as viewed by the operator with the punch block in the front.

1.06 In the illustrations, fixed pivot points are shown solid black, and those mounted on parts that move are shown cross-hatched.

2. TECHNICAL DATA

2.01 Some of the data that follows is approximate. The dimensions and weight given for the tape punch are for the unit removed from the associated typing unit.

2.02 This equipment is intended to be operated in a room environment within the temperature range of 40°F to 110°F. Serious damage to it could result if this range is exceeded. In this connection, particular caution should be exercised in using acoustical or other enclosures.

DIMENSIONS AND WEIGHT

2.03 The physical dimensions and weight of the 38 tape punch are as follows:

| | |
|------------------|--------------|
| Width | 4 inches |
| Depth | 5-1/2 inches |
| Height | 5-1/2 inches |
| Weight | 21 ounces |

TAPE SPECIFICATIONS

2.04 The 38 tape punch perforates oiled paper tape with specifications as follows:

| | |
|------------------------------|------------|
| Level | 8-level |
| Width | 1 inch |
| Character spacing | 10/inch |
| Feed hole diameter | 0.046 inch |

CHAD BOX

2.05 The dimensions of the chad box used with the tape punch are as follows:

| | |
|------------------|--------------|
| Width | 2-1/2 inches |
| Length | 7 inches |
| Height | 7-1/2 inches |

SPEED OF OPERATION

2.06 The 38 tape punch is capable of operating at speeds up to 100 words per minute.

3. DESCRIPTION AND PRINCIPLES OF OPERATION

3.01 The following paragraphs give detailed information on the major mechanisms of the tape punch (Figure 2). Also, the information applies to both the manual punch and the automatic punch. Control features peculiar to each punch are discussed in Part 4.

DRIVE MECHANISM

3.02 The rocking motion of the typing unit function rocker shaft is transferred to the tape punch through a sleeve on the rocker shaft, to a drive link and a plate with shaft on the punch (Figure 3). The drive link, attached to the plate with shaft, connects to the drive post and simultaneously drives the nudger, feed pawl, and stripper bail. The drive link also supplies the downward force to the sensing lever bail which pulls the selected pawls.

INTELLIGENCE TRANSFER MECHANISM

3.03 There is a codebar extension for the number 1, 2, 3, 4, 5, 6, 7, and 8 codebars in the typing unit (Figure 4). Motion is imparted to the codebar extensions by the codebars through the typing unit reset bail. A bracket and a plate mounted to the tape punch base provide support and guide for the codebar extensions.

3.04 The typing unit selector blocking levers control the mark or space position of the typing unit codebars which, in turn, transfer this position to the codebar extensions. A blocked codebar represents a space, and an unblocked codebar represents a mark. Each codebar extension has a tab on its underside, which aligns with its respective sensing lever, pawl, lever, and punch pin combination.

3.05 During the drive mechanism's counterclockwise travel, the sensing levers, under spring tension, move up and sense the codebar extensions. Each sensing lever, except the feed lever, has a tab on its top side which aligns with its respective codebar extension.

3.06 When a codebar extension is spacing, the tab, located on its underside, aligns with the tab on the sensing lever. The tabs engage each other, and the sensing lever is blocked from pivoting to its most counterclockwise position.

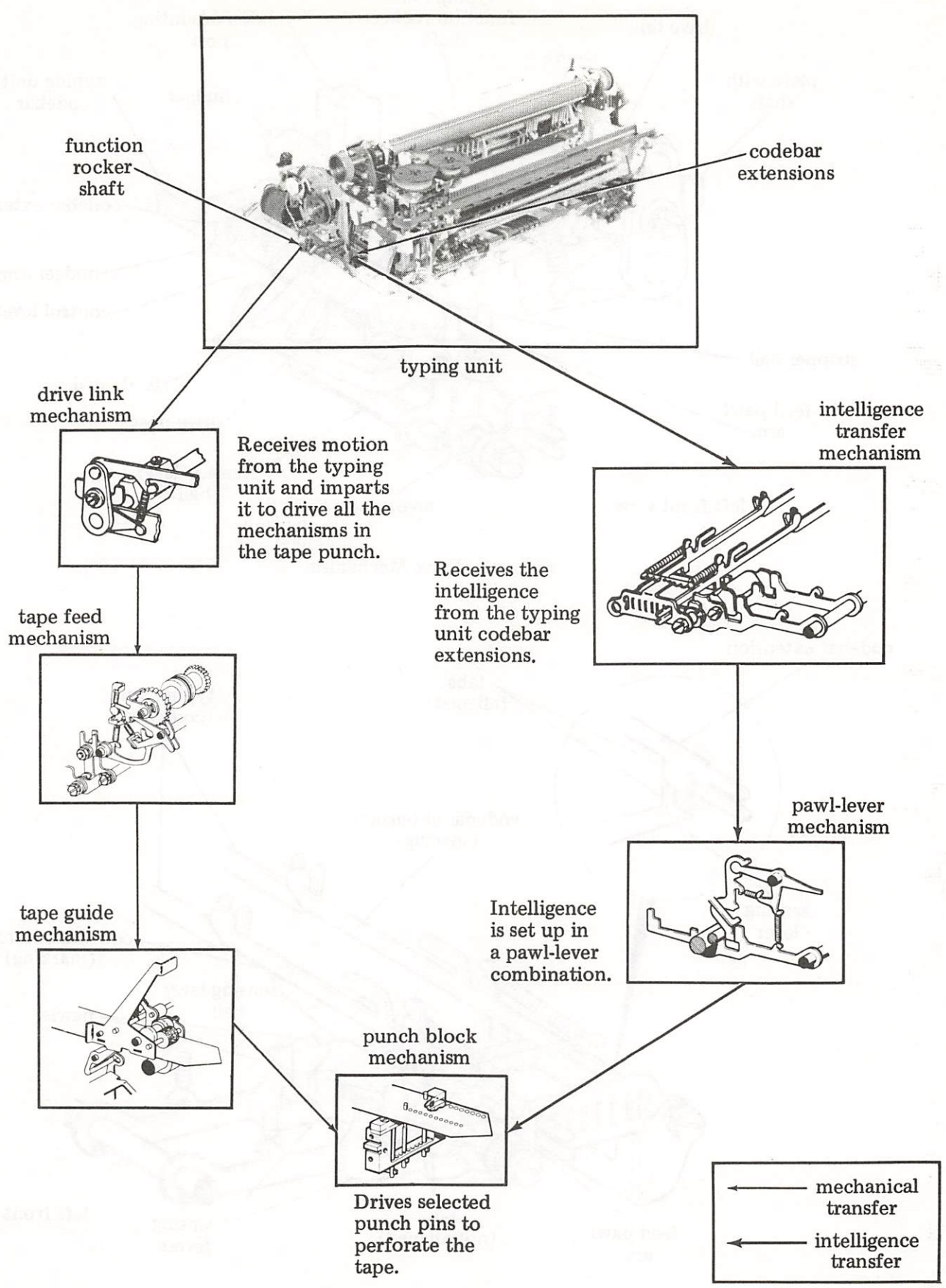

Figure 2 - Functional Diagram of Tape Punch Mechanisms

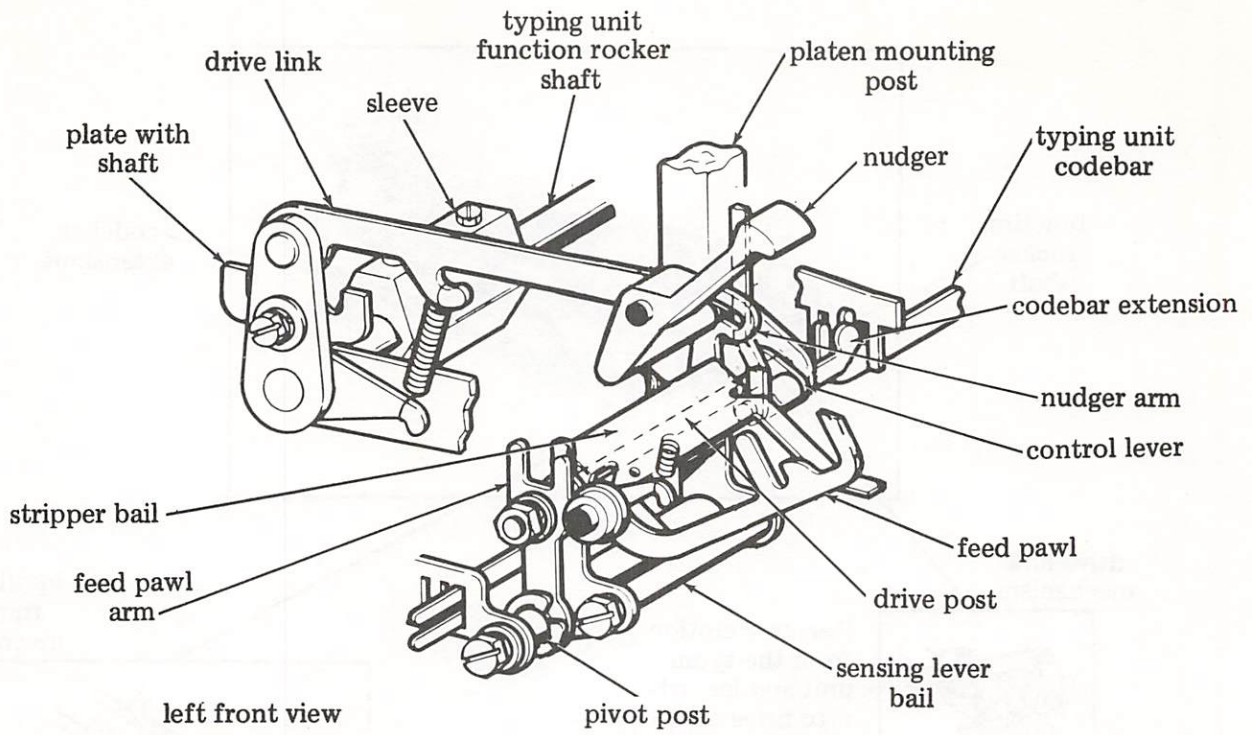

Figure 3 - Drive Mechanism

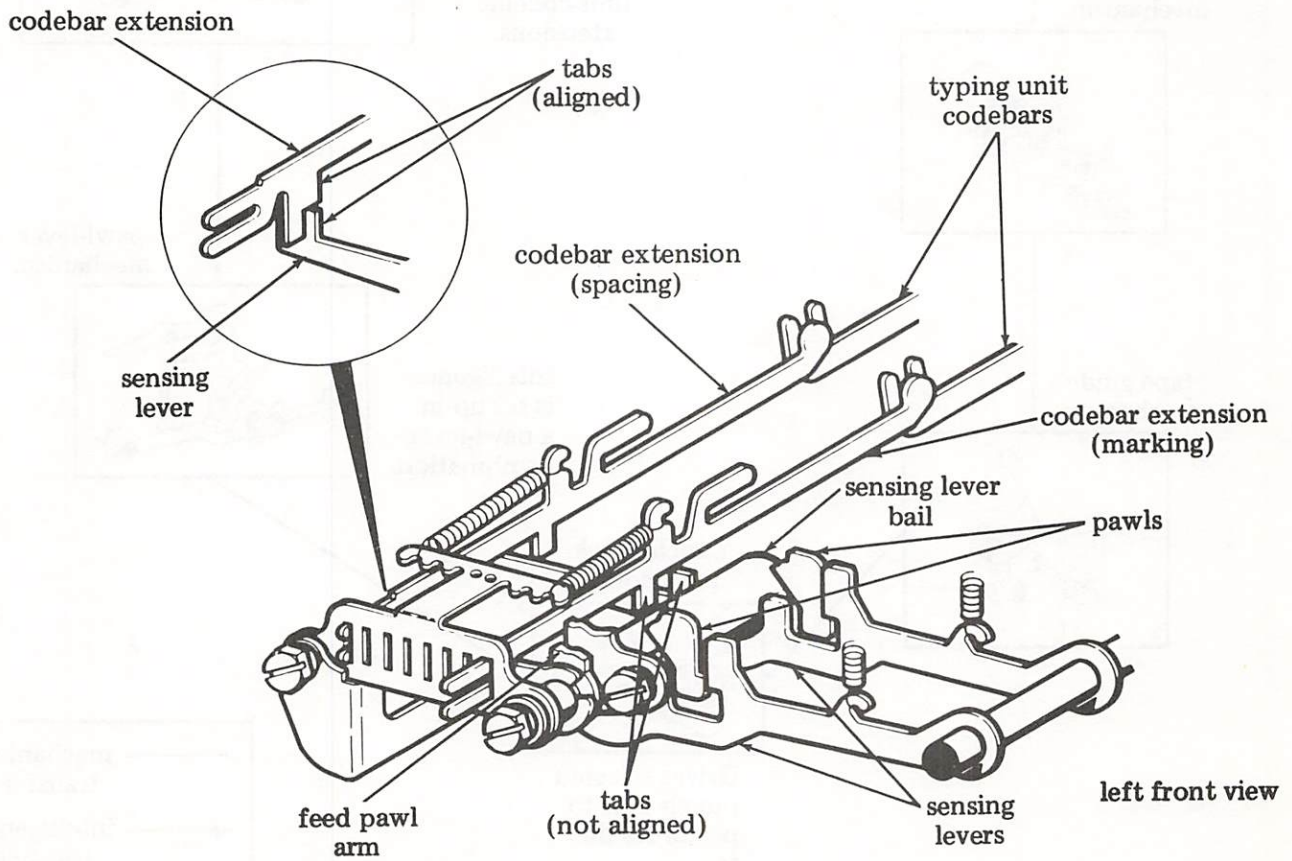

Figure 4 - Intelligence Transfer Mechanism

3.07 When a codebar extension is marking, its tab is not in line with the sensing lever tab. As a result the sensing lever pivots to its most clockwise position.

3.08 The feed sensing lever always travels to its most clockwise position, since it has no tabs. This motion is presented to the pawl, lever, and feed-punch pin combination through a latching surface on the pawl.

3.09 When the tape punch is off, each pawl is in its highest vertical position, each lever in its most clockwise position, and each code-punch pin in its most downward position — below the surface of the tape.

3.10 When a sensing lever is in the spacing position, its latching surface is prevented from engaging with its associated pawl latching surface. As a result the pawl is not selected.

3.11 When a sensing lever is in the marking position, its latching surface engages the latching surface on its associated pawl. When the two latching surfaces engage, the pawl is in the selected position.

3.12 As the drive mechanism (Figure 3) rotates clockwise, the feed pawl slides along the inclined surface of the adjacent ratchet tooth, drops behind it, and is cammed away from the feed wheel ratchet. Occurring simultaneously, the sensing levers in the marking position rotate counterclockwise and transfer their motion to the selected pawl, lever, and code-punch pin combination. At the same time, the drive mechanism transfers its motion to the sensing levers which are spacing. Since the pawl, lever, and code-punch pin combinations are in the nonselected position, no motion is transferred to them. This results in no perforation of the tape, since the code-punch pins remain in their most downward position below the tape's surface. As the drive mechanism continues and reaches its most clockwise position, the code-punch pin of a selected pawl, lever, and code-punch pin combination travels upwards, perforates a hole in the tape, and continues to its most vertical position. The feed hole is always perforated in the tape since its pawl and lever are always selected.

3.13 Just prior to the end of the drive mechanism's most clockwise travel, the stripper bail, through its bias spring, engages a

latching surface located under the spring hook(s) of the selected pawl(s). As the drive mechanism rotates counterclockwise to its stop position, the stripper bail strips the selected pawls from their sensing levers. The selected pawl, lever, and code-punch pin combinations return to their stop positions through their bias springs and the retractor mechanism. The lever bail of the drive mechanism also acts as a part of the retractor mechanism. As the stripper bail strips the pawls, a cam surface on the pawl, which acts as the other member of the retractor mechanism, engages the sensing lever bail post and cams the pawl upwards to the stop position. During this portion of the drive mechanism's travel, the codebar extensions are reset by the codebar reset bail.

3.14 During the drive mechanism's clockwise motion, the nudger (Figure 3) performs its function. Motion is transferred from a cam profile, located on the nudger arm, through a post molded as an integral part of the nudger. The nudger rotates counterclockwise, engages, and nudges the tape gently when the selected code-punch pins are engaged with the tape. This enables the tape to be advanced a small amount without affecting tape feed spacing, since only the weight of the paper between the tape roll is reflected to the feed wheel when the tape is being advanced.

TAPE FEED MECHANISM

3.15 As the stripper bail moves to the rear, the feed pawl engages a tooth on the feed wheel ratchet (Figure 5). When the stripper bail completes its travel to the rear, the feed wheel ratchet has indexed one full tooth and the tape is advanced 0.100 inch by the feed wheel.

TAPE GUIDE MECHANISM

3.16 The tape guide mechanism (Figure 6) consists of two plates, a bracket, two rollers, three posts, a sleeve, and a compression spring held together by retainers. A tension spring biases the tape guide mechanism in a clockwise direction.

3.17 The knurled roller settles against the knurled feed wheel with a predetermined force. It is the combination of force and knurled wheels that provide for adequate tape spacing. The tape guide assembly is shaped in the form of a funnel to provide easy tape threading. A release lever (Figure 6), when pushed back, rotates the tape guide mechanism in a counterclockwise direction and disengages the roller from the feed wheel, thereby providing easy tape removal and feeding.

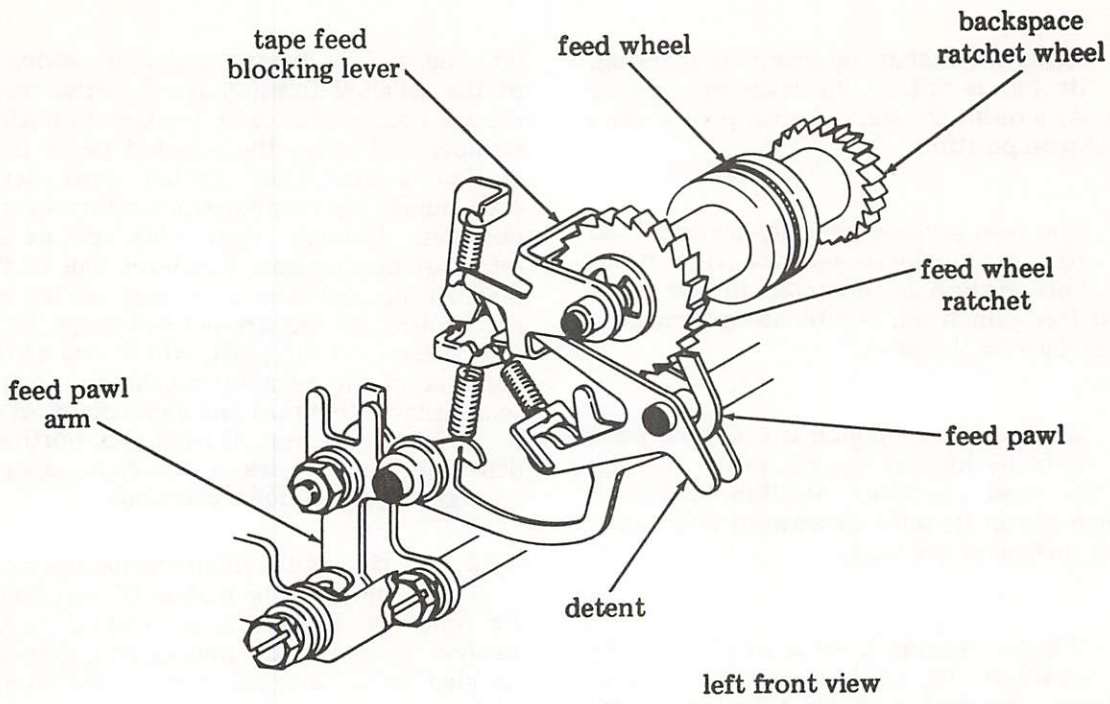

Figure 5 - Tape Feed Mechanism

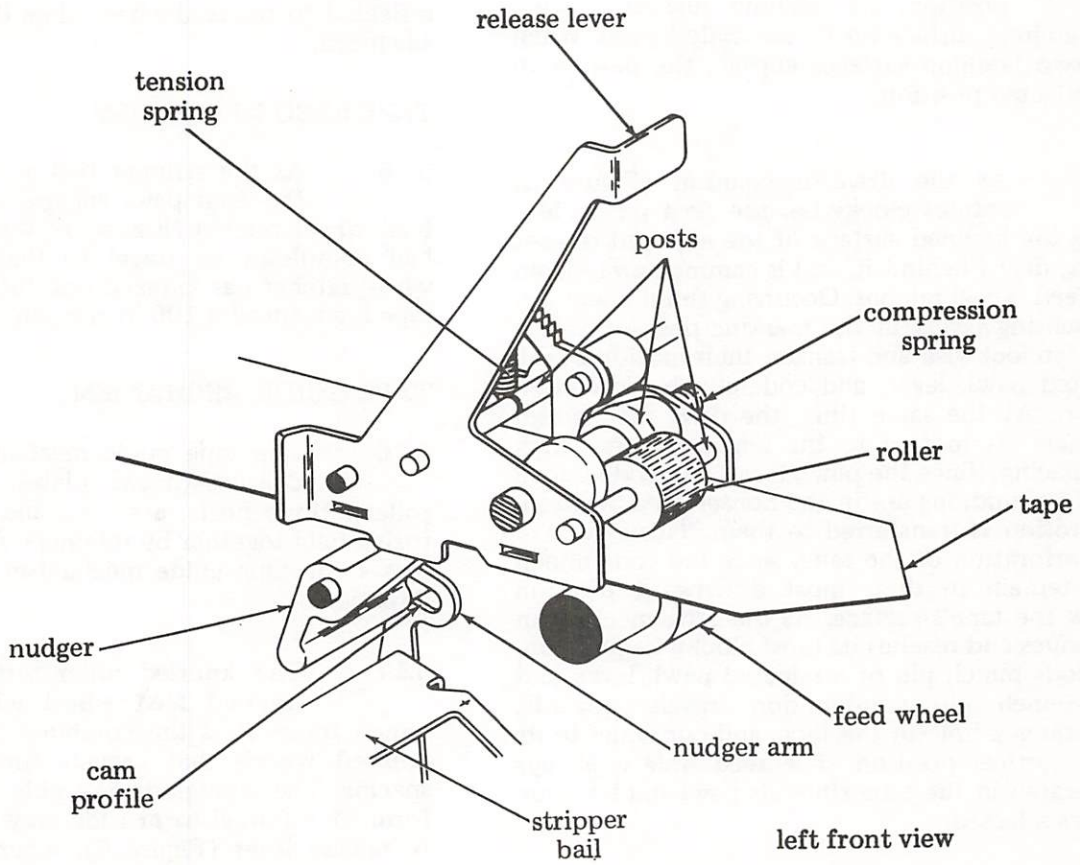

Figure 6 - Tape Guide Mechanism

PUNCH BLOCK MECHANISM

3.18 The punch block mechanism consists of code-punch pins, a feed-punch pin, holder, die plate, and a tape bias spring (Figure 7). The code-punch pins and feed-punch pin are oriented to the die plate through slots which engage levers in their respective code level. The tape bias spring always biases the tape against one edge of the holder. This results in the code hole and feed hole relation to the tape edge to be held constant.

BACKSPACE MECHANISM

3.19 The backspace lever, when moved by the control lever, backspaces the ratchet one tooth (Figure 8). This results in the tape being backspaced one full character. The

backspace lever, through the tape feed blocking lever, cams the feed pawl clear of the feed wheel teeth before the backspace pawl engages the teeth on the backspace ratchet wheel.

4. CONTROL FEATURES

MANUAL PUNCH

4.01 The manual tape punch is controlled only by the punch control lever (Figure 9). The controls for manual operation are listed in Table A.

AUTOMATIC PUNCH

4.02 The automatic tape punch (programmable, see Part 5), responds to ASCII control codes. The controls for automatic operation are listed in Table B.

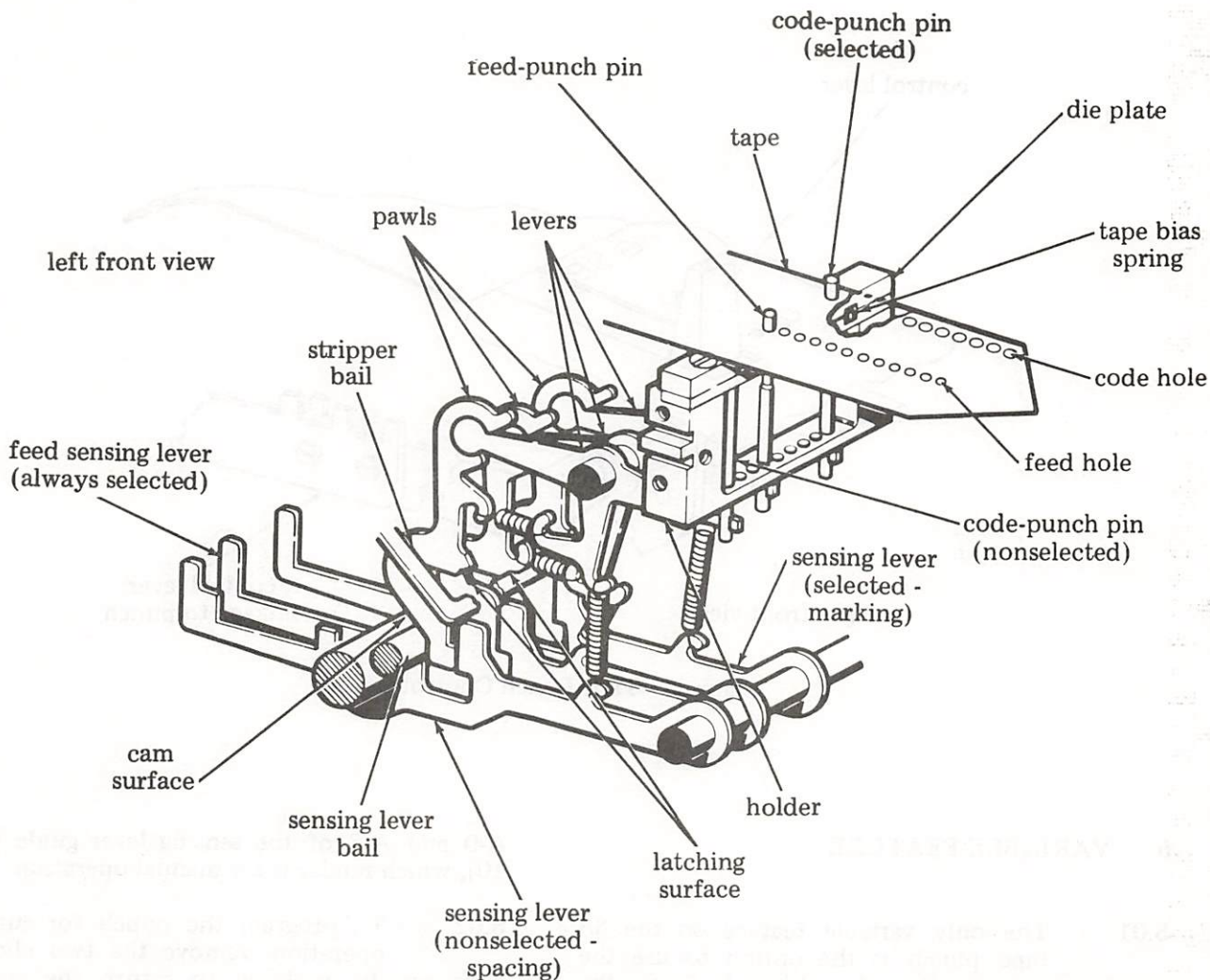

Figure 7 - Punch Block Mechanism

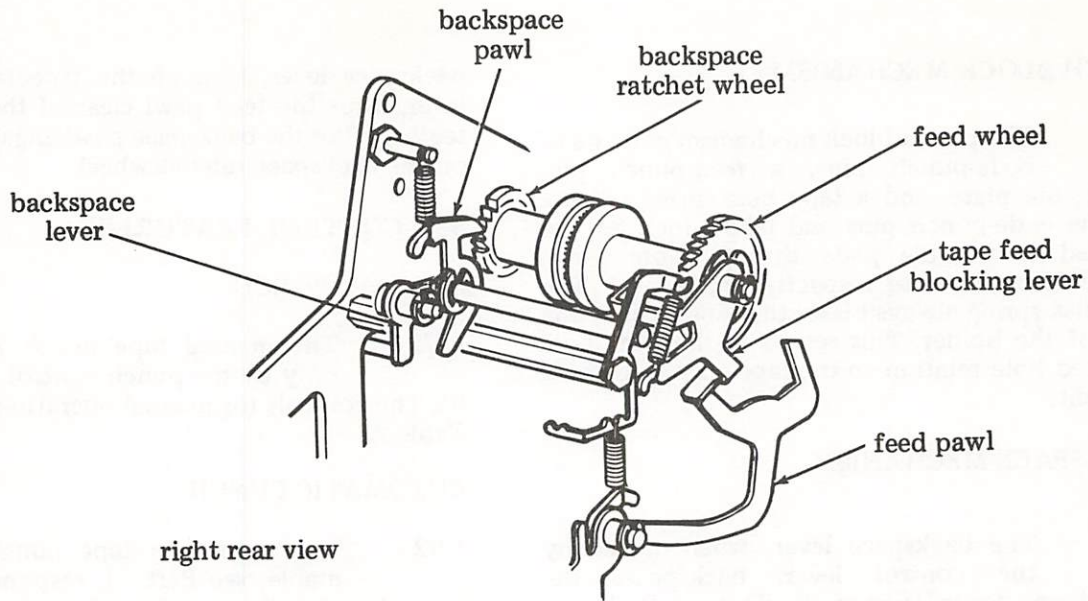

Figure 8 - Tape Backspace Mechanism

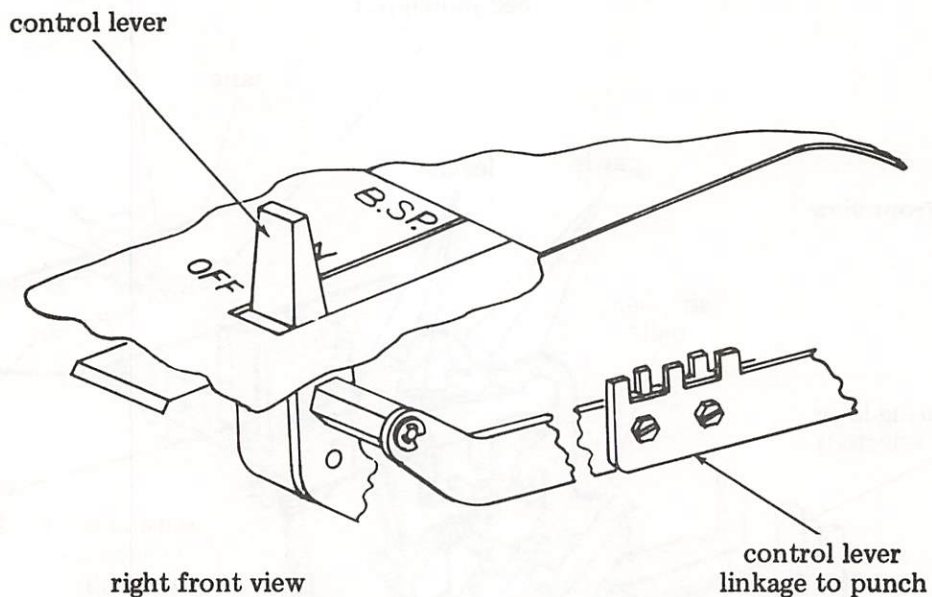

Figure 9 - Tape Punch Control Lever

5. VARIABLE FEATURE

5.01 The only variable feature on the 38 tape punch is the option to use the punch automatically. As shipped from the factory, the punch has two clips installed in slots

A-0 and A-8 of the sensing lever guide (Figure 10), which render it for manual operation.

5.02 To program the punch for automatic operation, remove the two clips. The clips can be replaced to return the punch to manual operation.

TABLE A

MANUAL PUNCH CONTROLS

| CONTROL | OPERATION |
|---------|--------------------------------------------------------------------------------------------------------------------------------------------------------------------------------------------------|
| B.SP. | Primarily used for tape correction. Each time the control lever (Figure 9) is moved to this position, the tape backspaces one full character. |
| ON | In this position, the tape punch operates and permits characters received by the typing unit to be punched in the tape. The tape punch will remain on despite any on-line signal to turn it off. |
| OFF | With the control lever in this position, the tape punch is inactive, and will remain so despite any on-line signal to turn it on. |

TABLE B

AUTOMATIC PUNCH CONTROLS

| CONTROL | OPERATION |
|---------|-------------------------------------------------------------------------------------------------------------------------------------------------------------------------------------------------------------------------------------------|
| B.SP. | Same as manual operation. |
| ON | The automatic tape punch can be turned on by either moving the control lever (Figure 9) to the ON position, or by the receipt of the DC ₂ ASCII signal from the associated keyboard, or a remote terminal via the signal line. |
| OFF | Once on, the automatic tape punch can be turned off by either moving the control lever to the OFF position, or by the receipt of the DC ₄ ASCII signal from the associated keyboard, or a remote terminal via the signal line. |

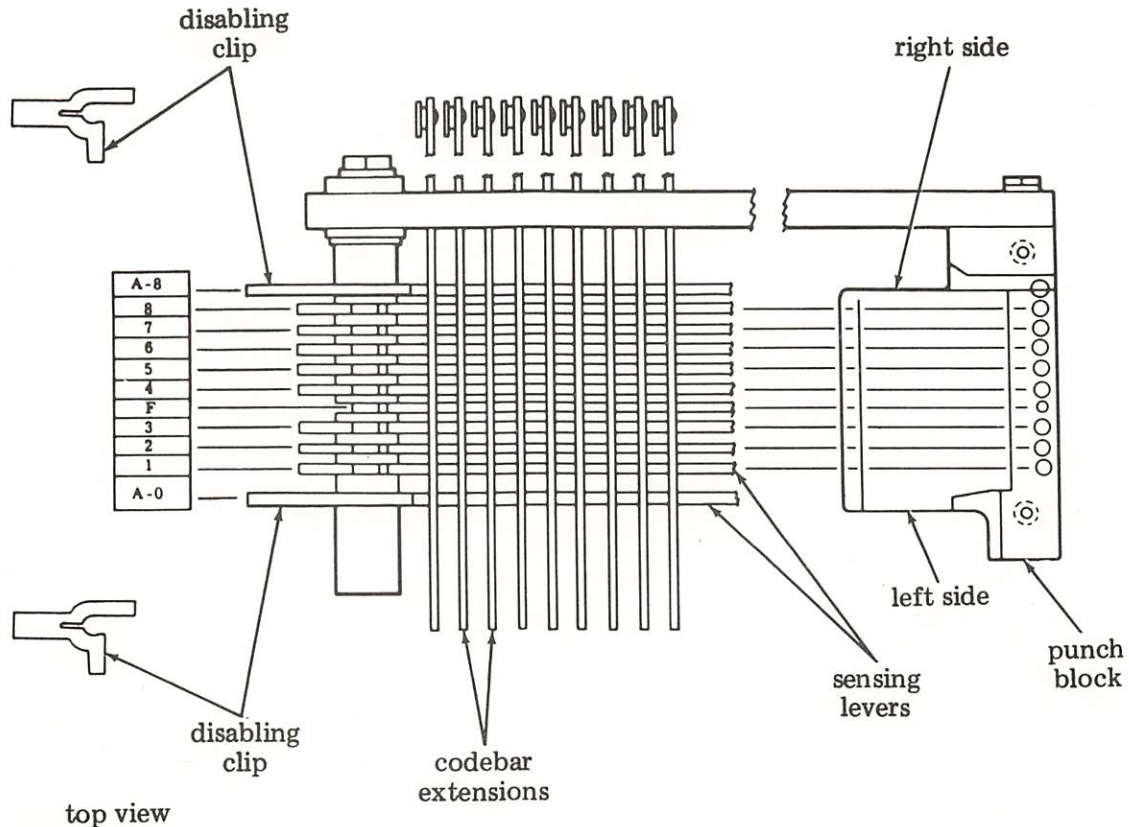

Figure 10 - Sensing Levers and Disabling Clips Slot Assignment

38 PUNCH

LUBRICATION

| CONTENTS | PAGE |
|-------------------------------------|------|
| 1. GENERAL | 1 |
| 2. BASIC UNIT | 2 |
| Backspace lever | 6 |
| Codebar levers | 4 |
| Detent lever | 6 |
| Drive link mechanism area | 2 |
| Drive link mechanism | 2 |
| Feed mechanism | 5 |
| Feed pawl | 6 |
| Pawls and levers | 5 |
| Punch block assembly | 7 |
| Sensing levers | 4 |
| Stripper bail | 4 |
| Support link | 2 |
| Tape guide assembly | 7 |
| Tape guide roller | 7 |
| Tape punch | 3 |

apply oil to locations where parts rub, slide, or move with respect to each other. Apply grease to gear teeth and points of heavy pressure.

1.04 Lubricate the punch before placing it in service, and just before placing it in storage. After about 100 to 200 operating hours, relubricate punch. Thereafter, lubricate punch every 750 operating hours or six months, whichever occurs first.

1.05 The following symbols and their meaning apply to the lubrication points in each paragraph:

| <u>SYMBOL</u> | <u>MEANING</u> |
|---------------|--------------------------------------------|
| D | Dry — no lubricant permitted |
| G | Grease — apply KS7471 grease as instructed |
| O | Oil — apply KS7470 oil as instructed |

1. GENERAL

1.01 This section provides lubrication procedures for the Model 38 Punch. It is reissued to change the lubrication interval in 1.04 and add a note in 2.13. To remove the punch as a unit from the teletypewriter, refer to Section 574-400-702TC.

1.02 Lubrication of the punch is presented by mechanisms. Photographs show numbered callouts which correspond to paragraphs containing line drawings. These line drawings show the specific points of each mechanism to be lubricated.

1.03 Lubricate the punch thoroughly. Apply oil to points where it will adhere and not run off. Avoid overlubrication. In general,

NOTE: Quantity of lubricant is normally given in the text associated with the mechanism.

1.06 References to front, rear, left, right, etc, are made viewing the punch from its normal operating position.

CAUTION: DISCONNECT POWER BEFORE APPLYING ANY LUBRICANT. DO NOT USE SOLVENTS TO CLEAN PLASTIC PARTS OR PROTECTIVE FINISHES. USE A SOFT DRY CLOTH. IF NECESSARY, USE A SOFT DAMP CLOTH WITH MILD DETERGENT, THEN RINSE AND BUFF WITH A SOFT DRY CLOTH.

2. BASIC UNIT

2.01 Drive Link Mechanism Area

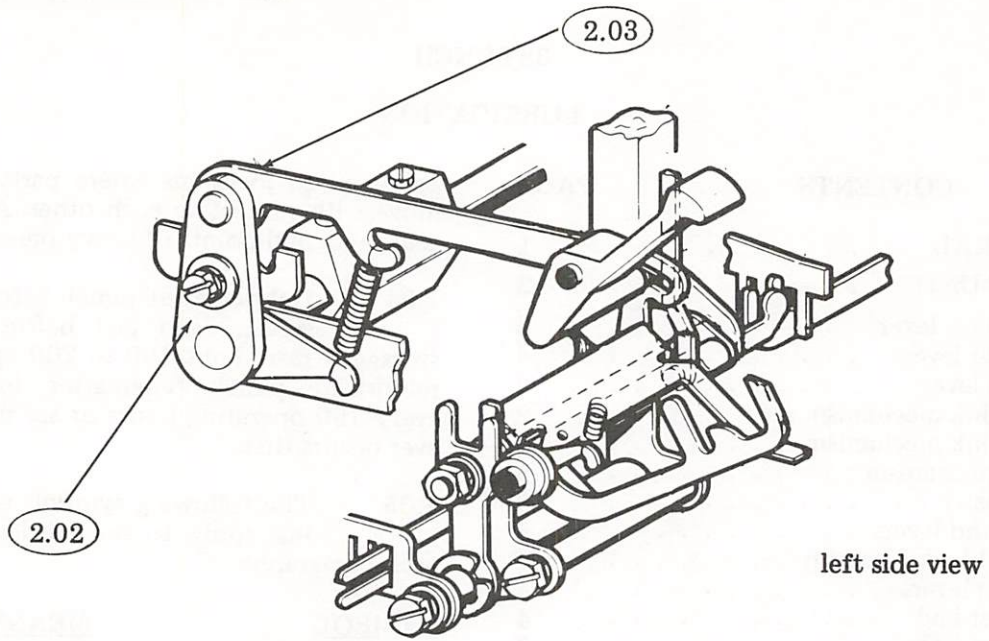

2.02 Drive Link Mechanism

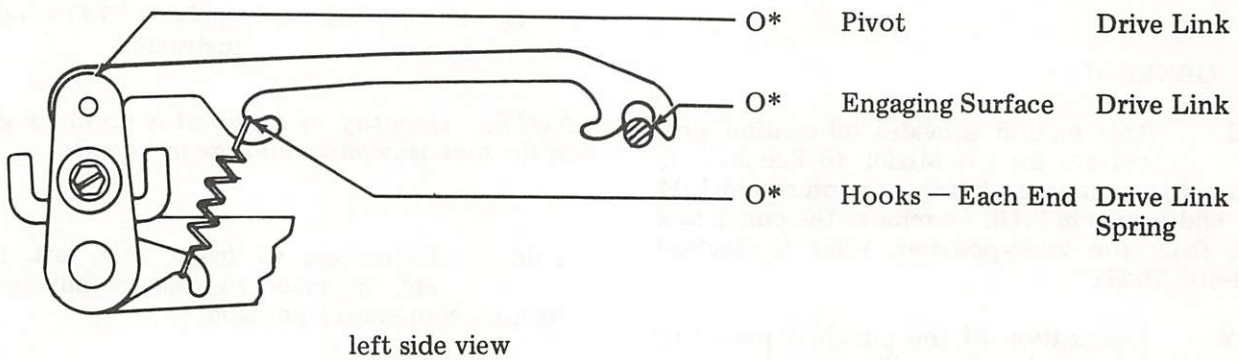

2.03 Support Link

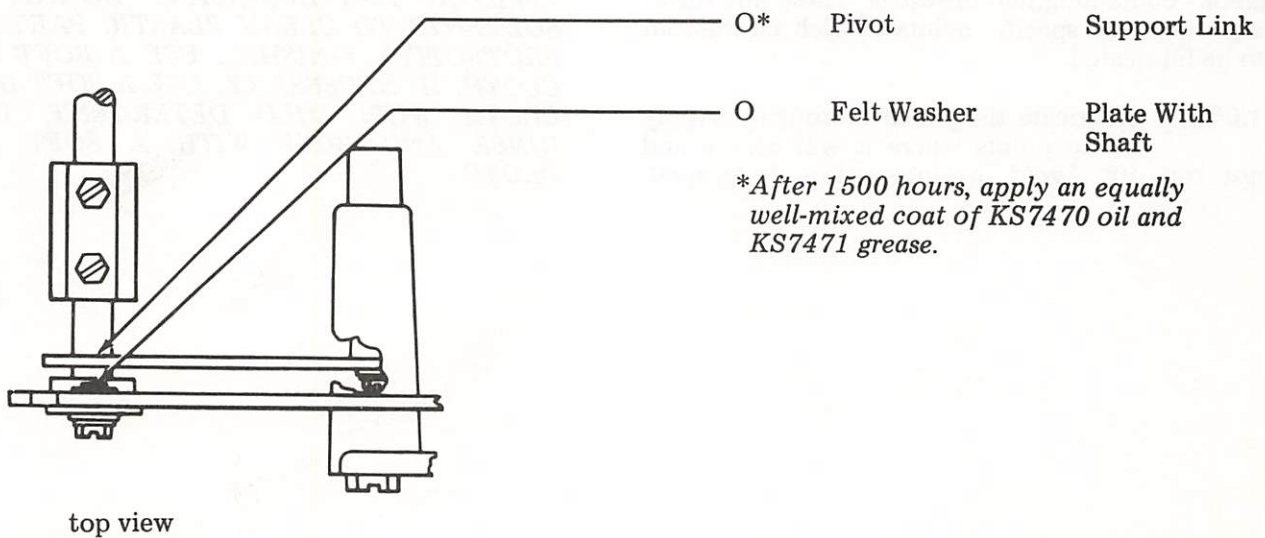

2.04 Tape Punch

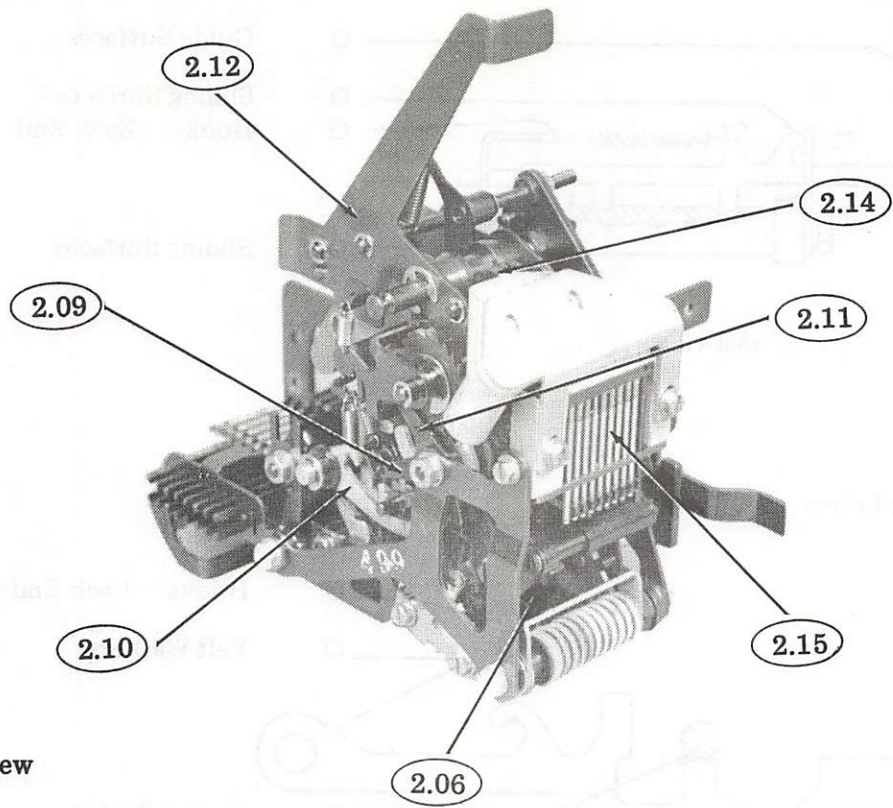

left front view

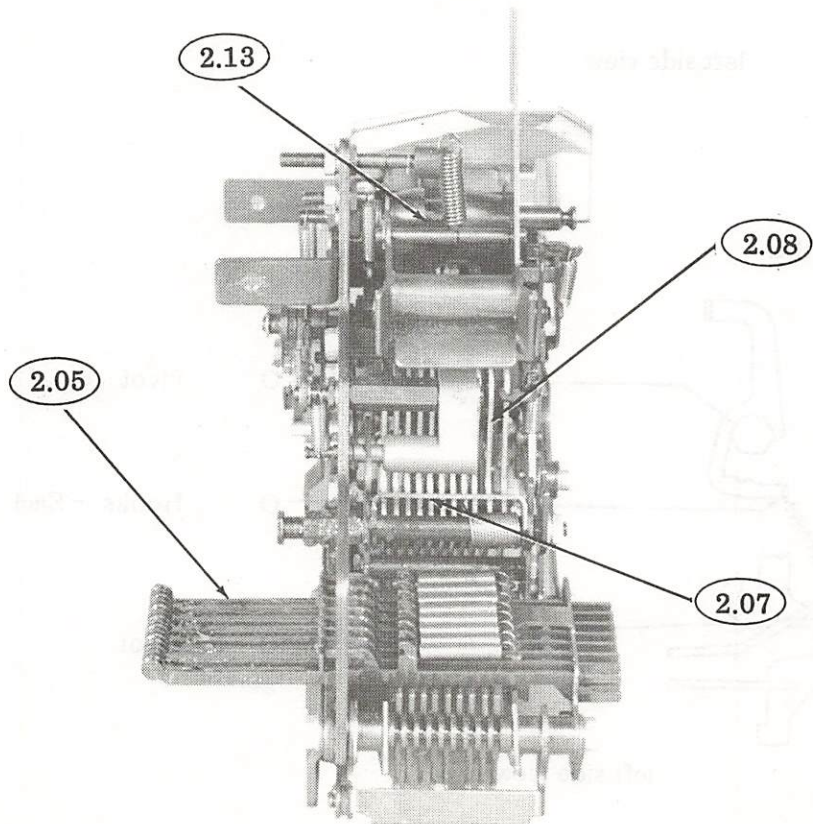

rear view

2.05 Codebar Levers

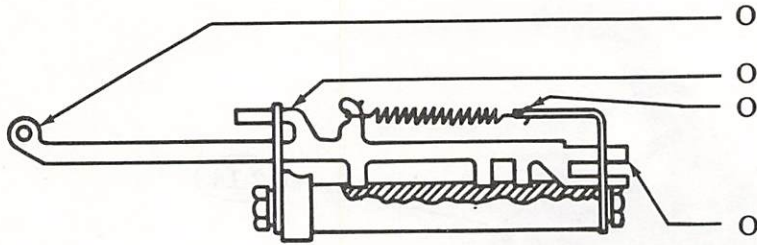

rear view

- | | | |
|---|------------------|-----------------------|
| ○ | Guide Surfaces | Codebar Extensions |
| ○ | Sliding Surfaces | Codebar Levers |
| ○ | Hooks — Each End | Codebar Lever Springs |
| ○ | Sliding Surfaces | Codebar Levers |

2.06 Sensing Levers

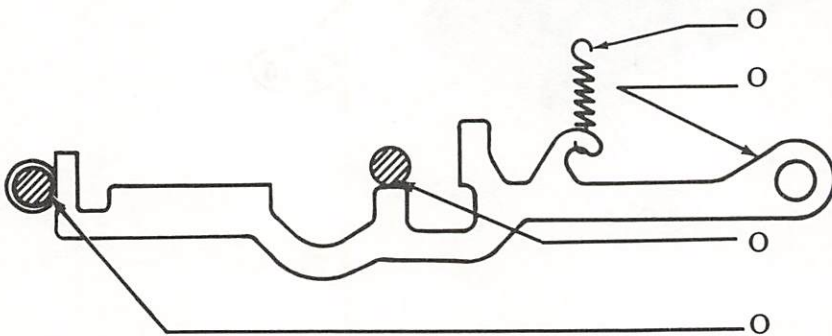

left side view

- | | | |
|---|------------------|-----------------------|
| ○ | Hooks — Each End | Sensing Lever Springs |
| ○ | Felt Washers | Sensing Levers |
| ○ | Sliding Surface | Sensing Levers |
| ○ | Sliding Surfaces | Sensing Levers |

2.07 Stripper Bail

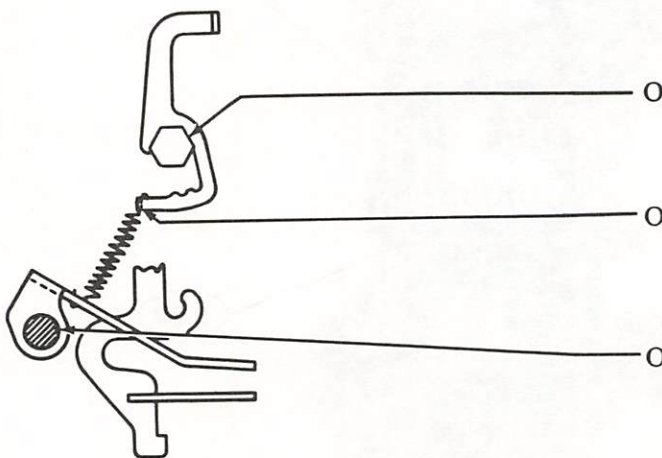

left side view

- | | | |
|---|------------------|----------------------|
| ○ | Pivot | Hook |
| ○ | Hooks — Each End | Stripper Bail Spring |
| ○ | Pivot | Stripper Bail |

2.08 Pawls and Levers

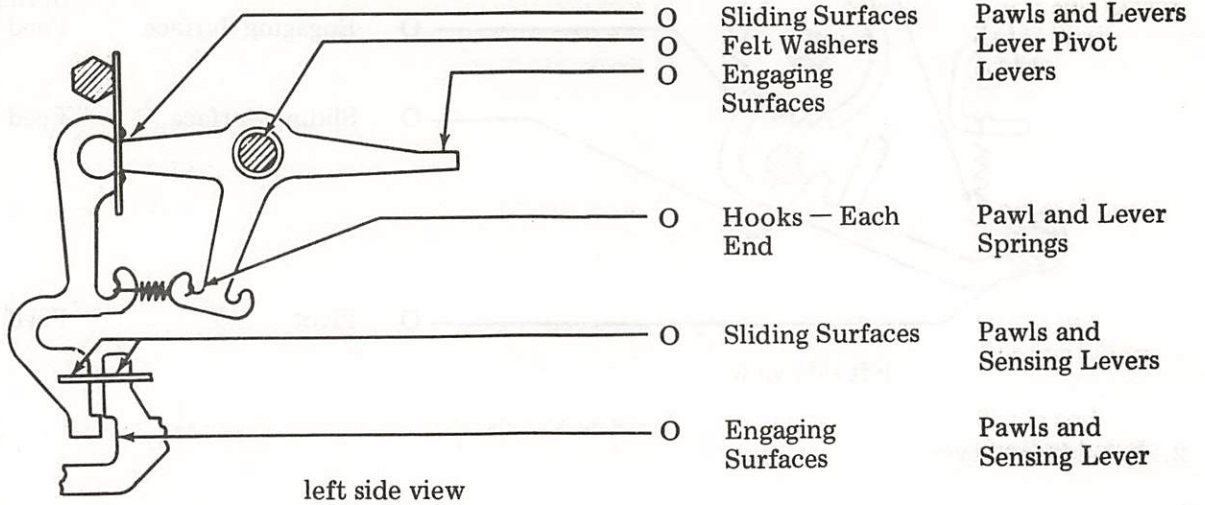

2.09 Feed Mechanism

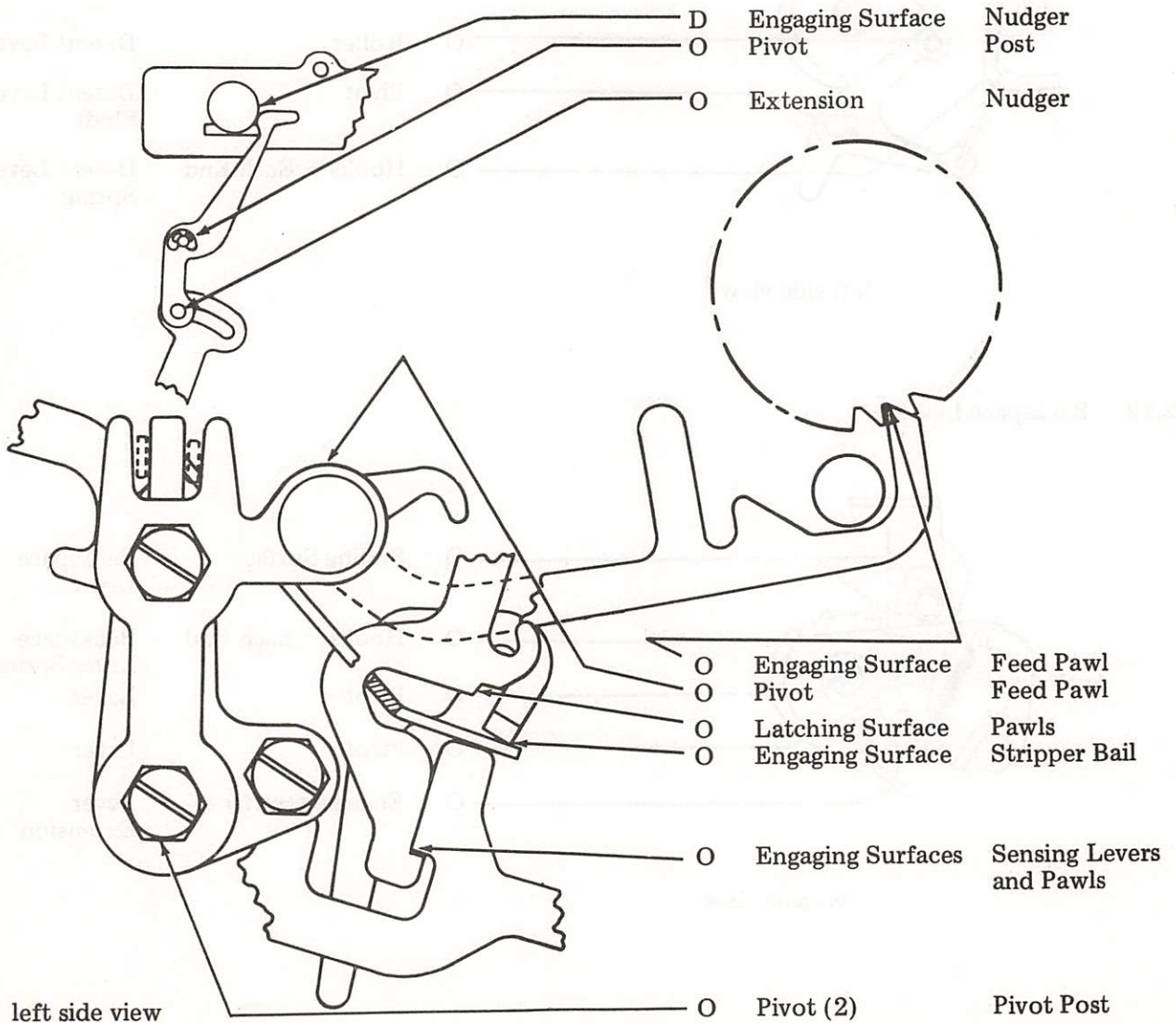

2.10 Feed Pawl

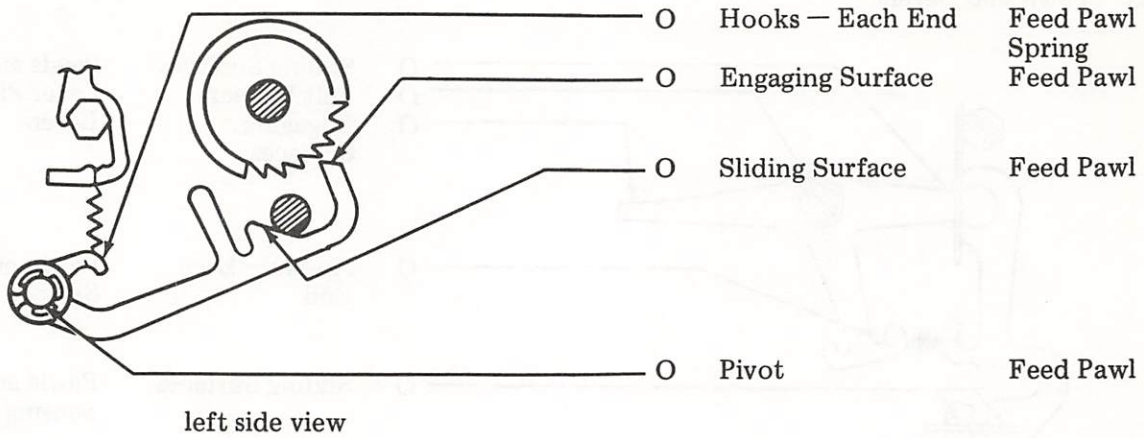

2.11 Detent Lever

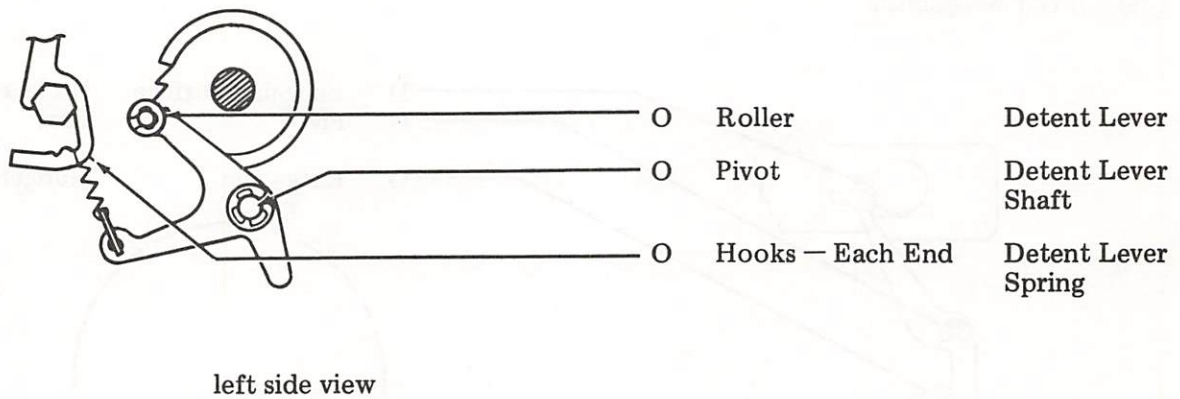

2.12 Backspace Lever

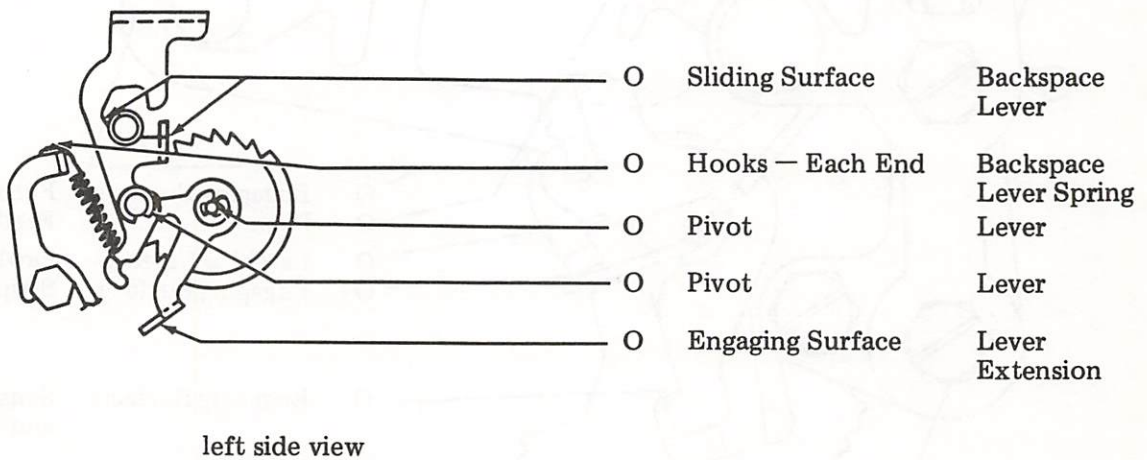

2.13 Tape Guide Assembly

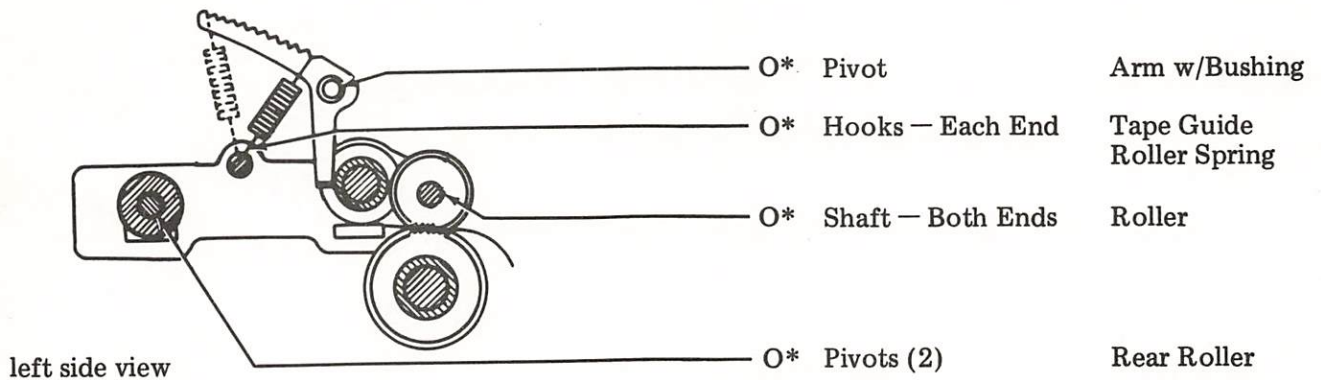

**Place a light amount of oil
to avoid contaminating tape.*

2.14 Tape Guide Roller

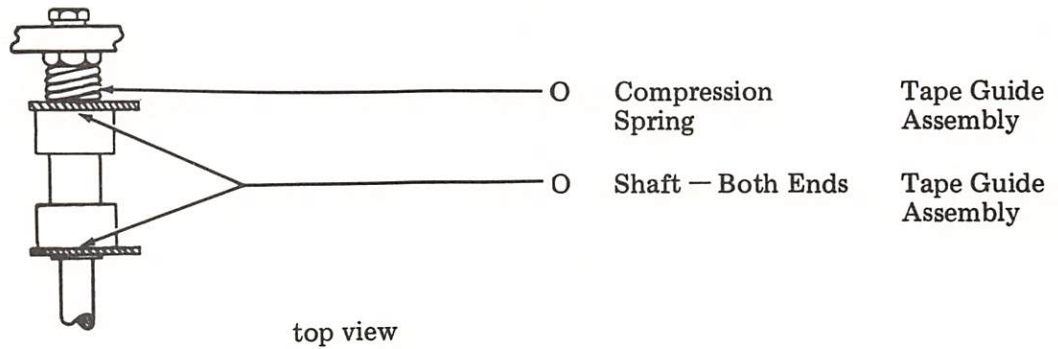

2.15 Punch Block Assembly

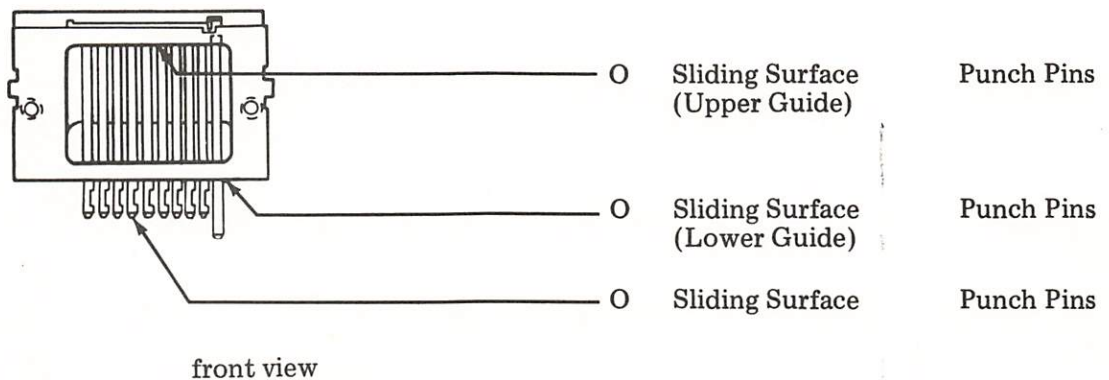

38 PUNCH

DISASSEMBLY AND REASSEMBLY

| CONTENTS | PAGE |
|--------------------------------------------------------------|------|
| 1. GENERAL | 1 |
| 2. PUNCH | 1 |
| TAPE GUIDE ASSEMBLY | 1 |
| CHAD CHUTE ASSEMBLY | 1 |
| PUNCH BLOCK ASSEMBLY | 1 |
| FEED PAWL UPSTOP ASSEMBLY | 3 |
| SENSING LEVERS AND GUIDEPLATE | 3 |
| FEED PAWL, DETENT LEVER, AND SPRING COMBINATION | 4 |

1. GENERAL

1.01 This section provides disassembly and reassembly instructions for the 38 punch. The instructions are confined to major subassemblies only. It is reissued to make some corrections throughout the section. Marginal arrows are omitted. If further disassembly and reassembly of the punch is required, refer to Section 574-425-800TC.

2. PUNCH

TAPE GUIDE ASSEMBLY

2.01 Disassemble tape guide assembly (Figure 1) as follows:

- (a) Note position of tape guide roller spring on notched arm with bushing, then remove spring.
- (b) Remove notched arm with bushing.
- (c) Remove mounting nut, lockwasher, and retaining ring.

- (d) Remove large retaining ring.
- (e) Remove detent lever spring on right side.
- (f) Remove spring post.
- (g) Remove tape guide assembly and its post.

2.02 Reassemble tape guide assembly by reversing procedure in 2.01.

CHAD CHUTE ASSEMBLY

2.03 Disassemble chad chute (Figure 1) as follows:

- (a) Remove chad chute extension from chad chute assembly.
- (b) Remove two screws, lockwashers, and flat washers from chad chute assembly and then remove chad chute assembly.
- (c) If necessary, remove gasket.

2.04 Reassemble chad chute by reversing procedure in 2.03.

PUNCH BLOCK ASSEMBLY

2.05 Disassemble punch block (Figure 2) as follows:

- (a) Remove three screws, lockwashers, and flat washers.
- (b) Slide punch block forward until tongue in block holder and pins disengage from groove in casting and code levers respectively.

2.06 Reassemble punch block as follows:

- (a) Replace block by positioning the slots in the punch pins until they face the guide pin.

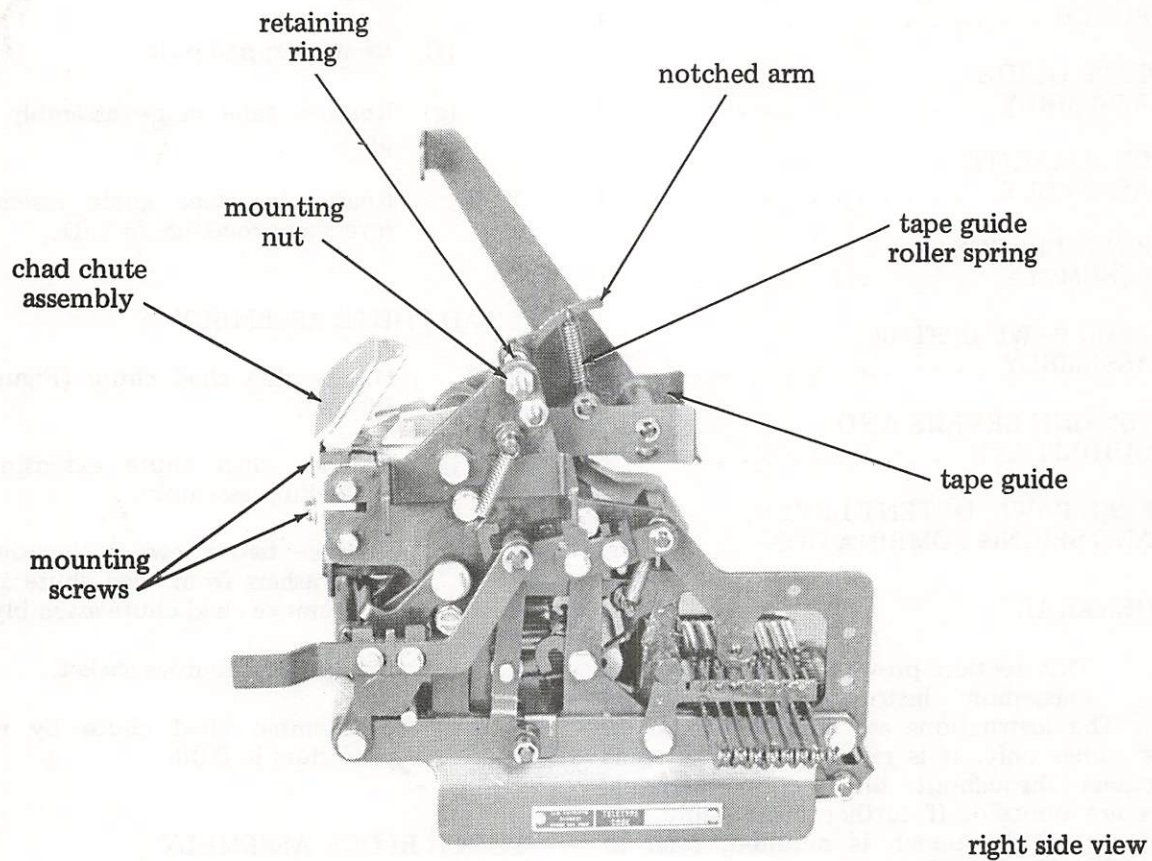

Figure 1 - Tape Guide and Chad Chute Assemblies

- (b) The bottom of punch pins should be in line and in a position that approximates their location on the punch.
- (c) Line up punch pin slots with their code levers.
- (d) Slide punch block back until slots of punch pins engage levers and screw holes line up.
- (e) Replace three screws and tighten.

FEED PAWL UPSTOP ASSEMBLY

2.07 Disassemble pawl upstop assembly (Figure 2) as follows:

NOTE: Do not disassemble pawl upstop before removing pawl, lever, and spring combination. The slotted plate keeps the "ball and socket" of the lever and pawl fully engaged.

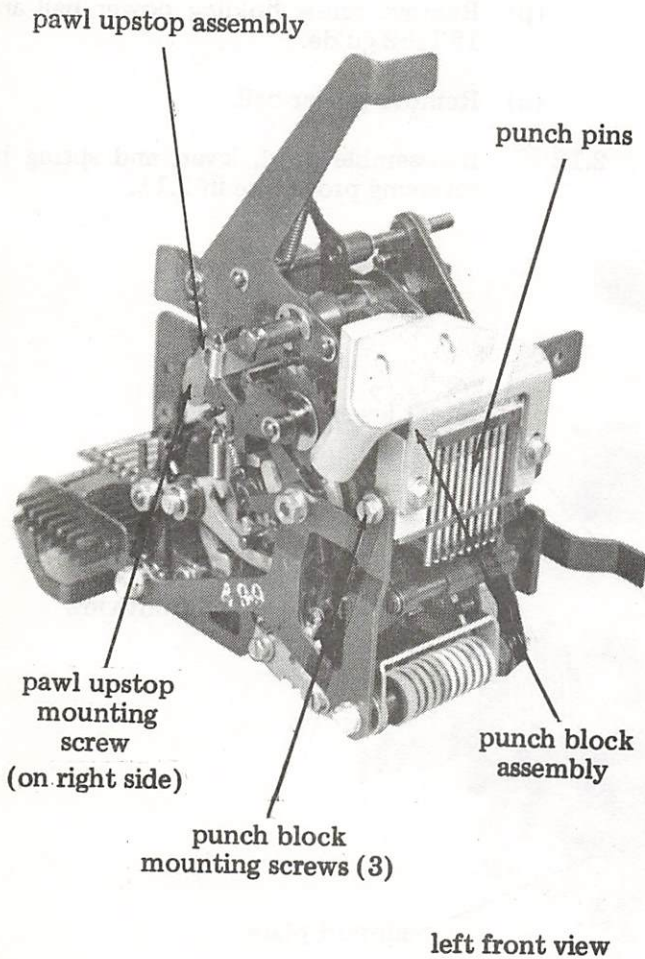

Figure 2 - Punch Block and Pawl Upstop Assemblies

- (a) Remove 45104 feed pawl spring, 185776 detent lever spring, 7655 back-space lever spring, and 182853 hook.
- (b) Remove mounting screw from post.
- (c) Remove post, bracket, and slotted plate.

2.08 Reassemble pawl upstop by reversing procedure in 2.07.

SENSING LEVERS AND GUIDEPLATE

2.09 Disassemble sensing levers and guideplate (Figure 3) as follows:

- (a) Unhook each sensing lever spring.
- (b) Make sure pawls are unlatched, then rotate each sensing lever away from guideplate.

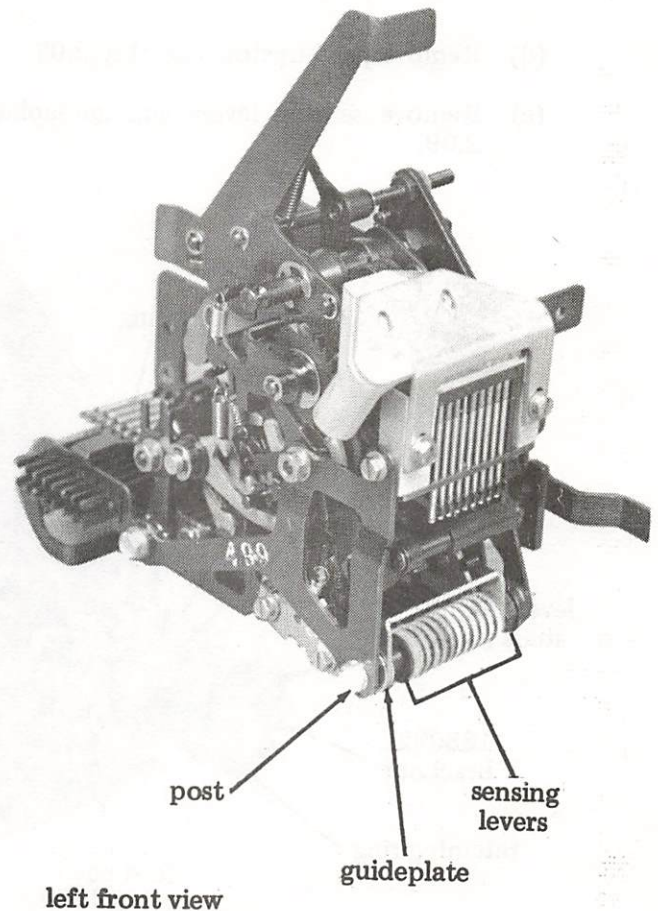

Figure 3 - Sensing Levers and Guideplate

- (c) Unhook 7603 latch bail spring.
- (d) Remove two screws from post, then remove post and sensing levers with latch bail assembly.
- (e) Remove post and nut from guideplate, then remove guideplate.

2.10 Reassemble sensing levers and guideplate by reversing procedure in 2.09. However, push guideplate downward to take up all play before tightening screw and nut in step (d). Position guideplate horizontally, in a slight counterclockwise position as gauged by eye.

FEED PAWL, DETENT LEVER, AND SPRING COMBINATION

2.11 Disassemble pawl, lever, and spring (Figure 4) as follows:

- (a) Remove tape guide assembly 2.01.
- (b) Remove chad chute assembly 2.03.
- (c) Remove punch block assembly 2.05.
- (d) Remove pawl upstop assembly 2.07.
- (e) Remove sensing levers and guideplate 2.09.

- (f) Remove eight 70466 springs.
- (g) Remove screw holding the 188092 bracket.
- (h) Remove bracket.
- (i) Remove remaining screw holding the 182455 guide to power bail.
- (j) Remove guide.
- (k) Remove eight levers with studs.
- (l) Remove screw and nut with washers holding support plate in place.
- (m) Remove support plate.
- (n) Remove retainer holding feed pawl to power bail.
- (o) Remove feed pawl from power bail and detent lever assembly from 185846 post together.
- (p) Remove screw holding power bail and 182452 guide.
- (q) Remove power bail.

2.12 Reassemble pawl, lever, and spring by reversing procedure in 2.11.

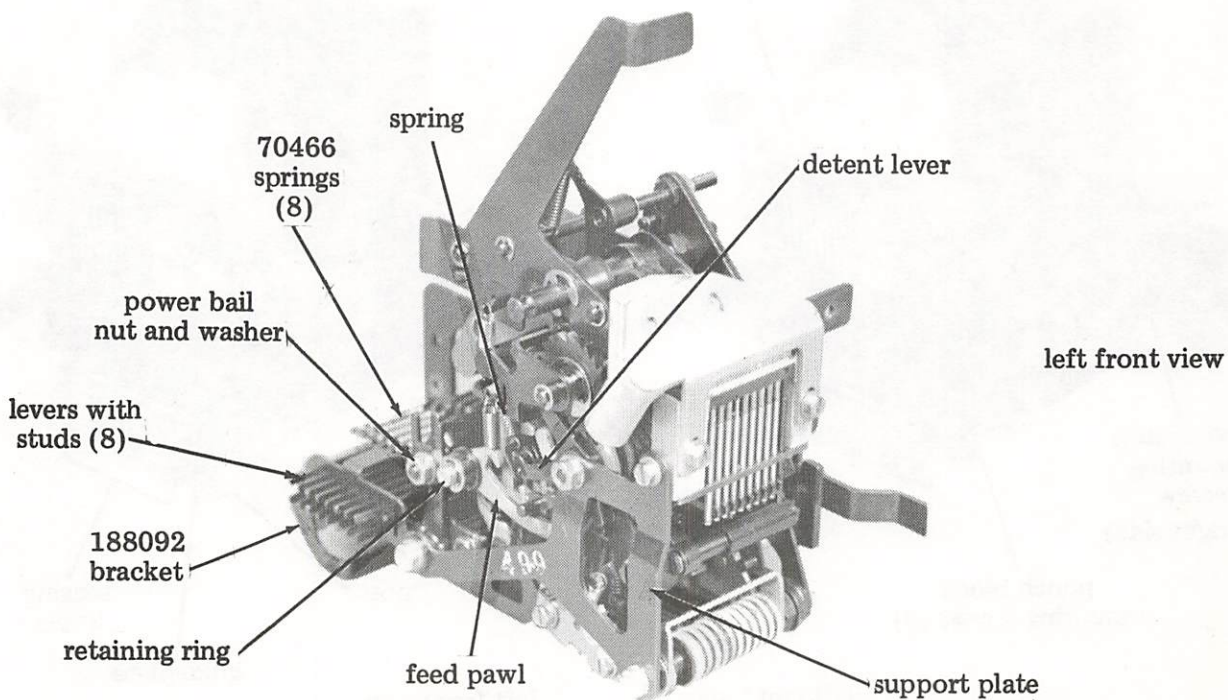

Figure 4 - Pawl, Lever, and Spring Combination

38 COVER
 LUBRICATION

| CONTENTS | PAGE |
|-----------------------------|------|
| 1. GENERAL | 1 |
| 2. COVER | 1 |
| ASR cover | 1 |
| Rear cover hinges | 2 |
| Lids | 2 |

relubricate cover. Thereafter, lubricate every 500 operating hours or six months, whichever occurs first.

1.04 The following symbols and their meaning apply to the lubrication points in the line drawing:

| <u>SYMBOL</u> | <u>MEANING</u> |
|---------------|---------------------------------------|
| O | Oil — Apply KS7470 oil as instructed. |
| D | Dry — No lubricant permitted. |

1. GENERAL

1.01 This section provides lubrication procedures for the Model 38 Cover. To remove the cover as a unit from the teletypewriter, refer to Section 574-400-702TC.

1.02 Lubrication of the cover is straight forward. A line drawing contains specific points of the cover to be lubricated. Apply oil as directed and to points where it will adhere and not run off.

1.03 Lubricate the cover before placing in service, and just before placing it in storage. After about 100 to 200 operating hours,

1.05 References to front, rear, left, right, etc, are made viewing the teletypewriter from its normal operating position.

CAUTION: DISCONNECT POWER BEFORE APPLYING ANY LUBRICANT. DO NOT USE SOLVENTS TO CLEAN PLASTIC PARTS OR DECORATIVE FINISHES. USE A SOFT DRY CLOTH. IF NECESSARY, USE A SOFT DAMP CLOTH WITH MILD DETERGENT, THEN RINSE AND BUFF WITH A SOFT DRY CLOTH.

2. COVER

2.01 ASR Cover

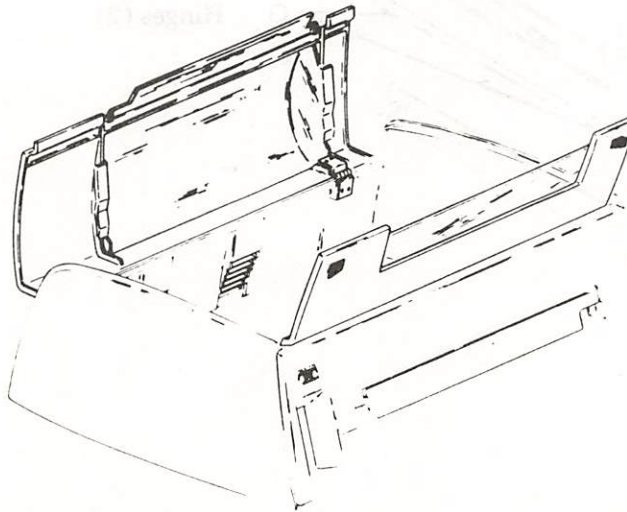

2.02 Rear Cover Hinges

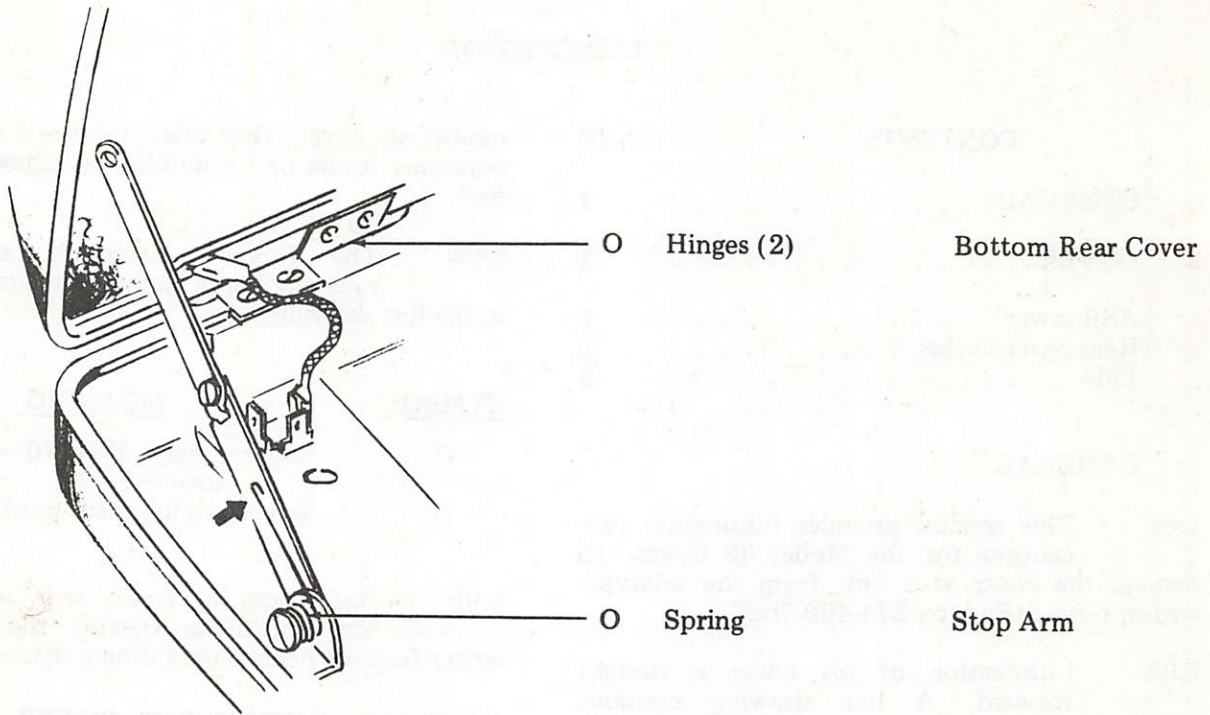

2.03 Lids

