



**MIDNIGHT**  
BLUE

August 2023

# ALL COPS ARE BROADCASTING

Breaking TETRA after decades in the shadows

By Midnight Blue



Jos Wetzels, MSc

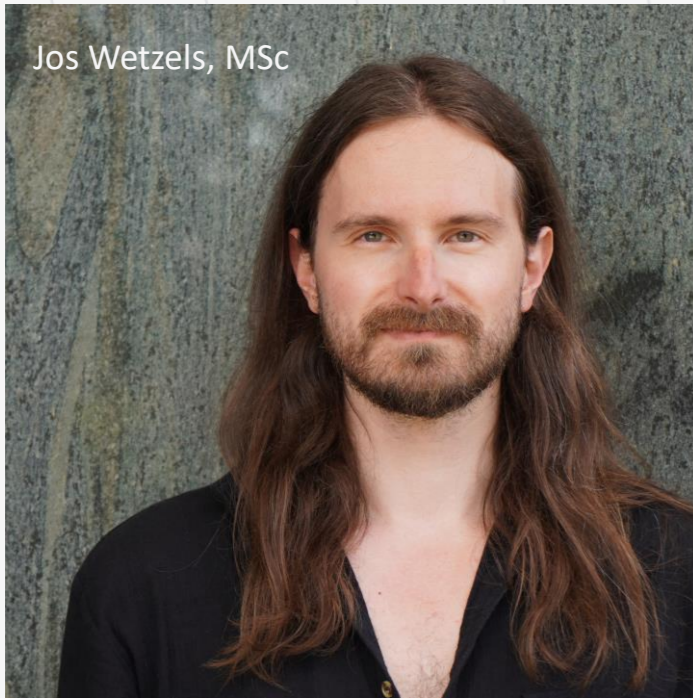

Carlo Meijer, MSc

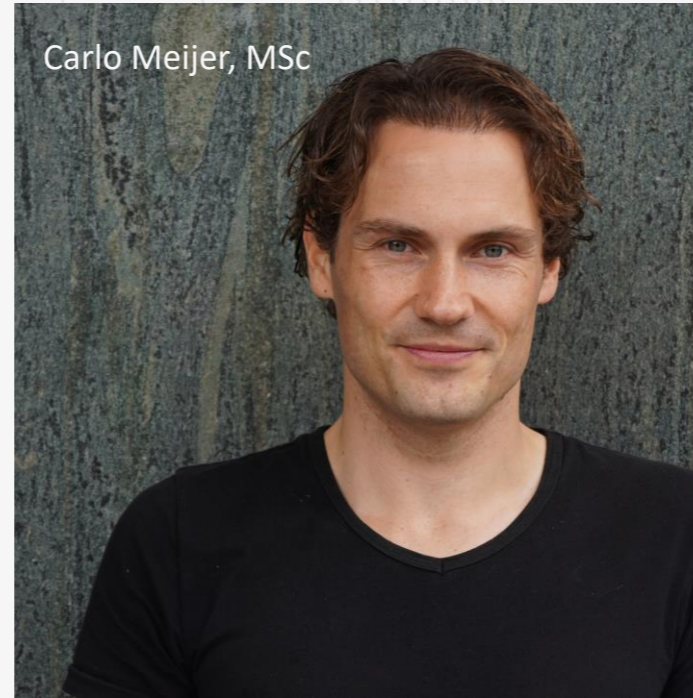

# Midnight Blue

Wouter Bokslag, MSc



FCA  
PSA

BlackBerry®

QNX®



Selected Research

# What is TETRA?

- Globally used radio technology
  - Competes with P25, DMR, TETRAPOL
- Standardized in 1995 by ETSI
  - Known for GSM, 3G/4G/5G, GMR, etc.
- Used for voice & data communications incl. machine-to-machine
- Relies on **secret, proprietary cryptography**

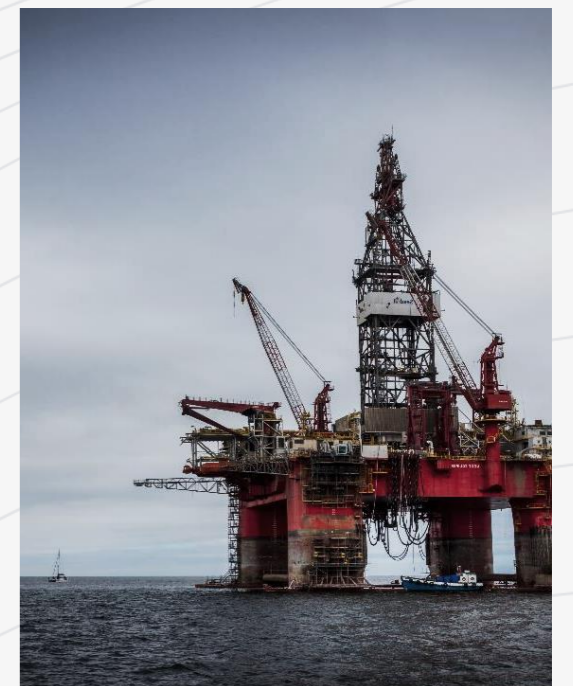
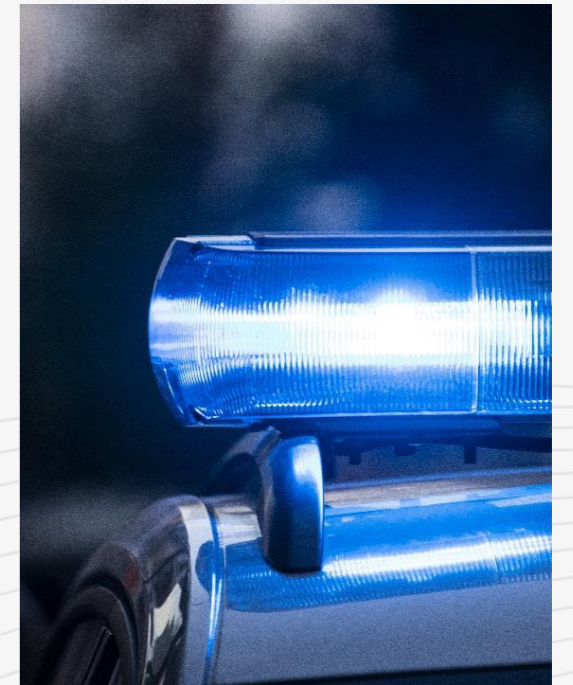

# Use by police



**Vast majority** of global police forces use TETRA radio technology.

- C2000 (NL)
- ASTRID (BE)
- BOSNET (DE)
- AIRWAVE (UK)
- Nødnett (NO)
- Raket (SE)
- SINE (DK)
- VIRVE (FI)
- SIRESP (PT)
- ...

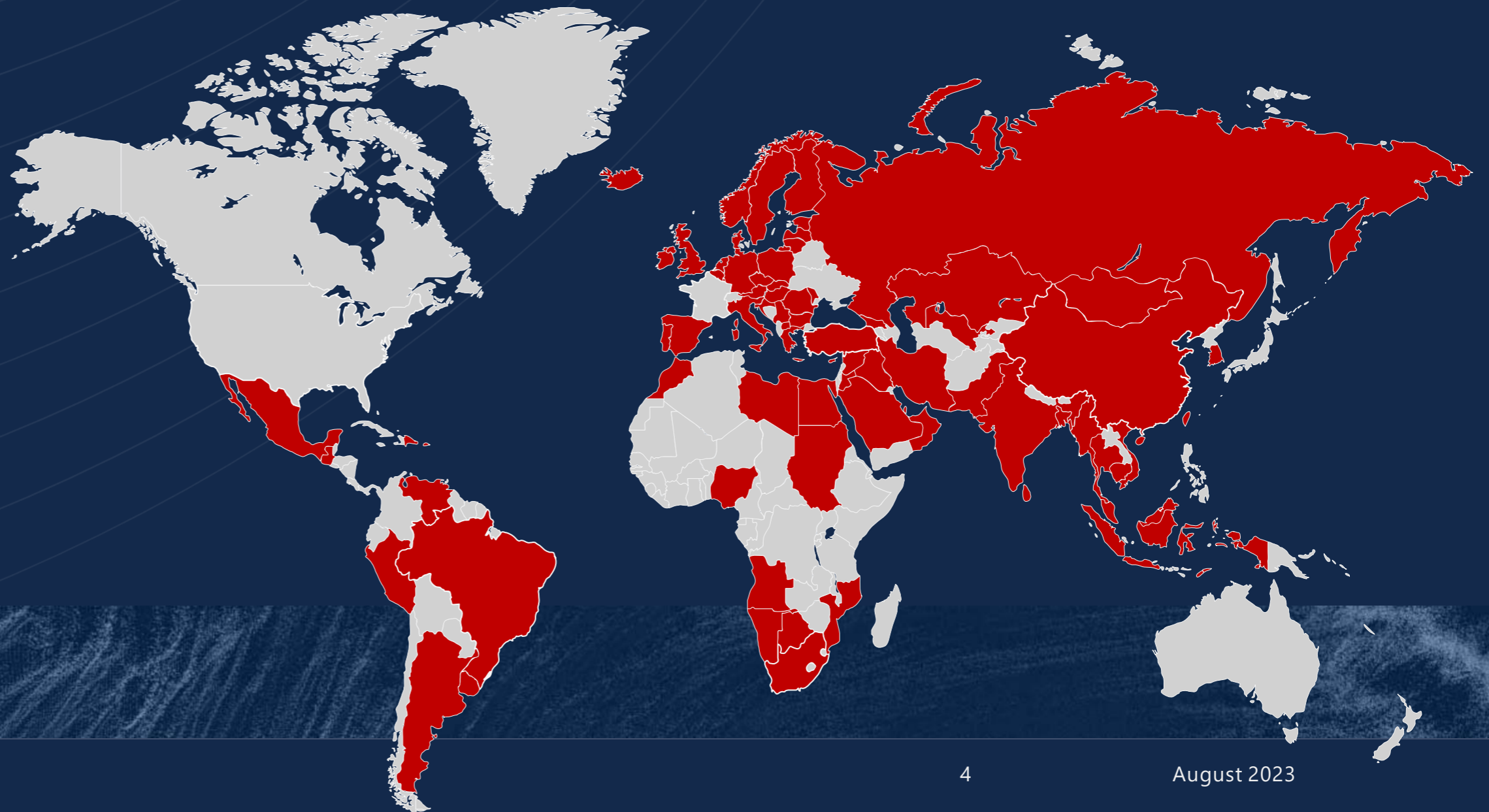

Based on OSINT

# Military & Intelligence

Many countries have one or more military or intelligence units using TETRA radio technology as primary, fallback, or interfacing comms.

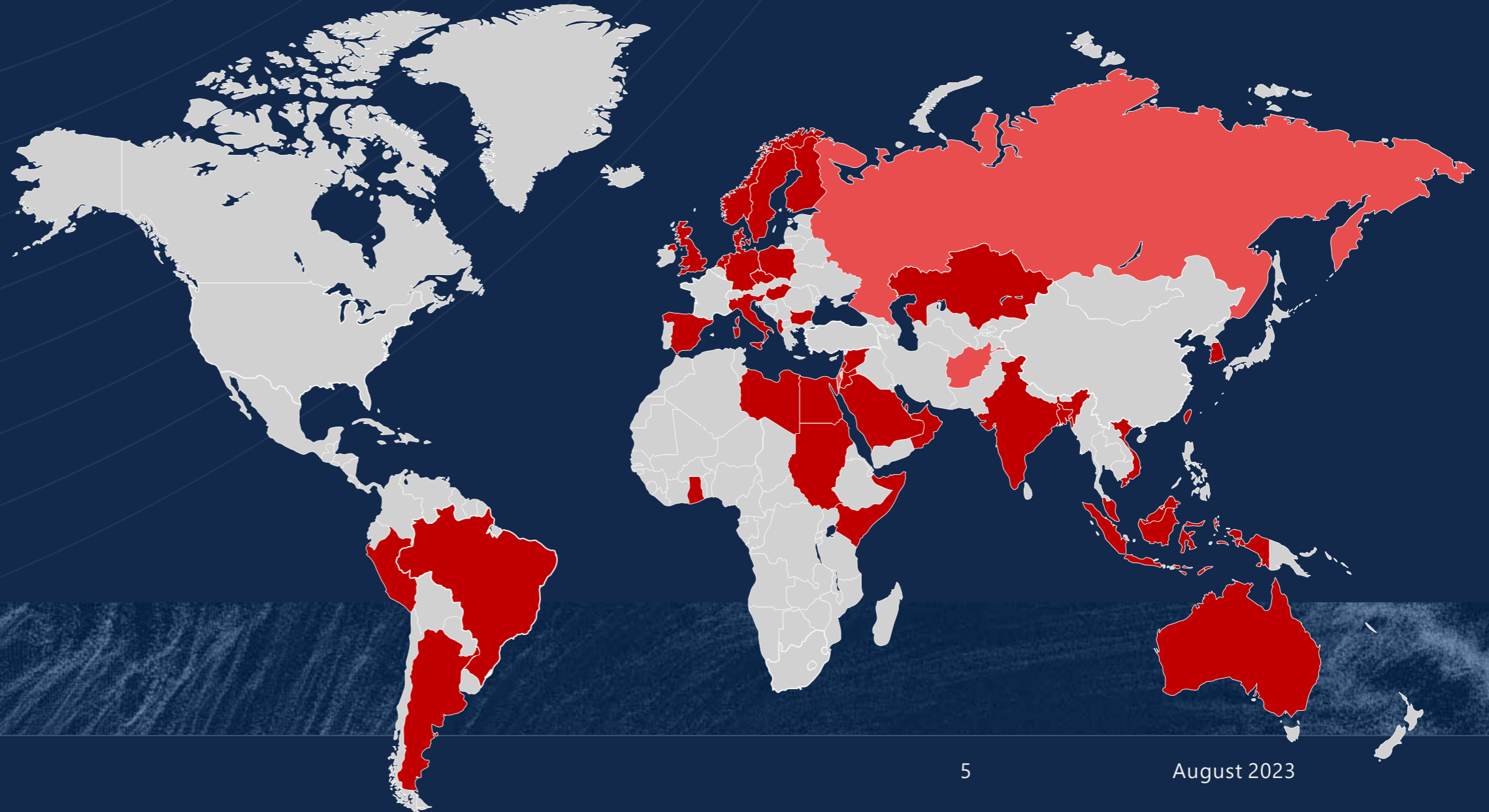

Based on OSINT

# Critical Infrastructure

Many parties such as airports, harbors, and train stations use TETRA for voice communications.

In addition TETRA is used for SCADA WAN, such as substation & pipeline control, or railway signalling.

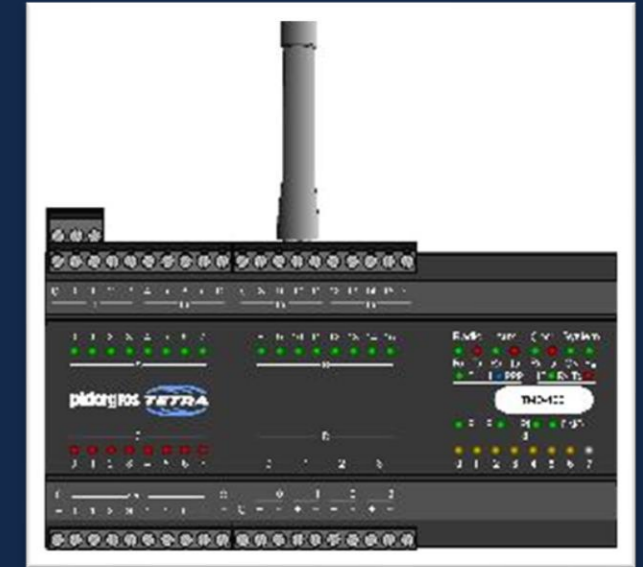

Based on OSINT

# Open standard?

- Public standard, **secret** crypto
  - NDAs, only available for 'bona fide' parties
- Manufacturers must protect algorithms
  - Hardware, or, implementations
  - Software with extraction countermeasures

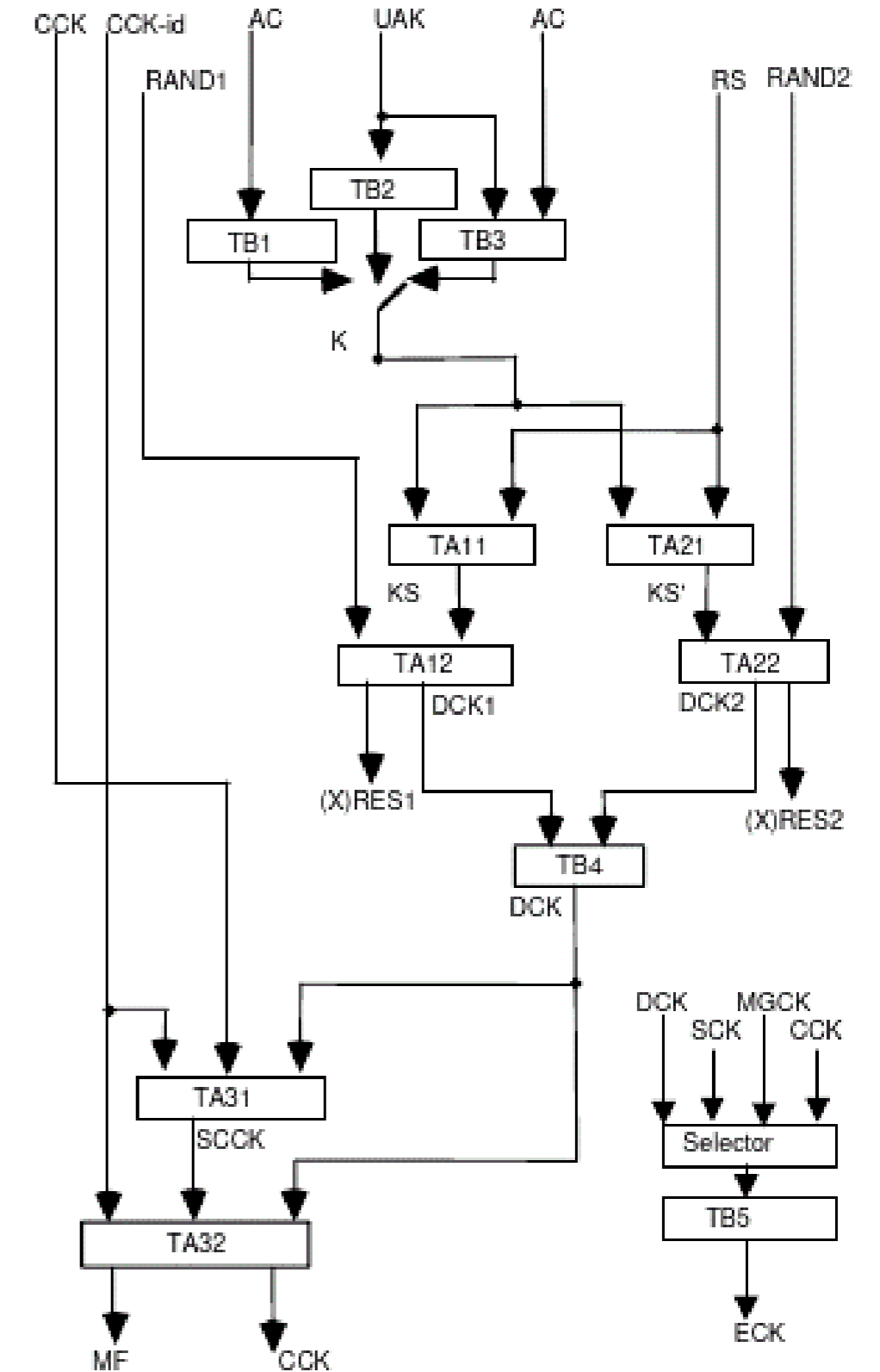

Figure B.1: Overview of air interface authentication and key management (sheet 1)



# Lots of 'bona fide' vendors

Significant amount of **geographically dispersed** players



Top-tier adversaries likely have specs (e.g. via in-country manufacturers or theft)



## Historical M&As

Teltronic, Simoco → Sepura, Nokia → Airbus, Rohde & Schwarz, PowerTrunk → Hytera, Selex ES → Leonardo, Chelton → Cobham, Artevea → dissolved.





# TETRA security

- **TAAI suite**
  - Authentication, key management / distribution (OTAR)
  - Identity encryption
  - Remote disable
- **TEA (TETRA Encryption Algorithm) suite**
  - Voice and data encryption (Air Interface Encryption (AIE))
    - **TEA1: Readily exportable**
    - **TEA2: European public safety**
    - **TEA3: Extra-European public safety**
    - **TEA4: Readily exportable (hardly used)**
  - Not to be confused with Tiny Encryption Algorithm!

# Optional: end-to-end



- Only used by some countries, usually for special cases only
- Not inside TETRA standard
  - Some guidelines / integrations are provided
- Proprietary solution on top of AIE
  - Expensive
- **Again, very opaque...**
  - High-level specification but no detail



# Project RE:TETRA

# Kerckhoffs' principle

**“A cryptosystem should be secure even if everything about the system, except the key, is public knowledge.”**

-Auguste Kerckhoffs, 1883



# Violators don't fare well

- A5/1, A5/2 (GSM), COMP128 (GSM)
  - GMR-1, GMR-2 (SATPHONES)
  - GEA-1, GEA-2 (GPRS)
  - DSAA, DSC (DECT)
  - MIFARE (RFID)
  - HITAG (RFID)
  - MEGAMOS (RFID)
  - DST (RFID)
  - Legic (RFID)
  - CSS (DVD)
  - CryptoAG / Hagelin
- Orange = backdoored

# ~~Kerckhoffs' principle~~ ETSI's principle

**“Well [obscurity is] also a way of maintaining security.”\***

-Brian Murgatroyd, Chairman ETSI TC TETRA, 2023

\* Interview between Kim Zetter and Brian Murgatroyd, Chair of ETSI TC TETRA  
<https://zetter.substack.com/p/interview-with-the-etsi-standards>



# Project motivation



- Proprietary cryptography has repeatedly suffered from practically exploitable flaws which remain unaddressed until disclosed
- GOAL: open up TETRA for public review **after 20+ years**
  - Enables informed risk analysis
  - Resolve issues
  - Level playing field
- Funded by NLnet
  - NPO funding open IT projects

# Research program



## Procurement

- Analyze landscape
- Obtain right radio (Motorola MTM5400)



## Analysis

- Firmware analysis
- Identify cipher location
- Develop tooling



## Cipher Extraction

- Hack the radio (multiple 0-days)
- Extract ciphers from radio



## Attack R&D

- Cipher reverse engineering
- Cryptanalysis
- Validate with PoC



# Pwning MTM5400

1. Format string → code exec on **AP**
2. Pivot to **DSP** via shared memory
3. Cache timing side-channel on **TEE**
4. **Secret algos!**  
... and key extraction ...
5. **More details at DEF CON**  
... we only have 40 minutes here 😞

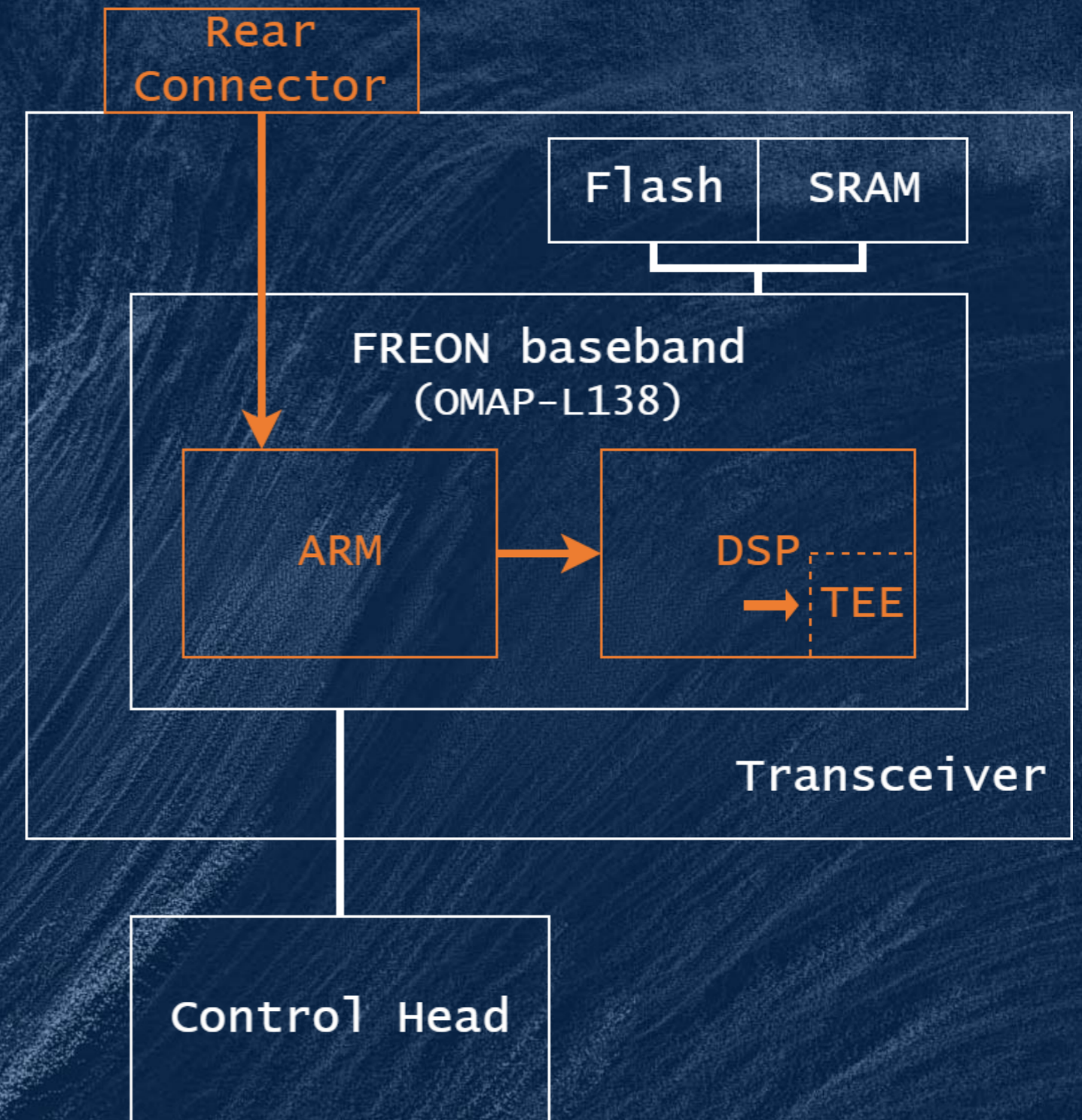



# The secret TETRA primitives and their security

# TAA1 auth and OTAR

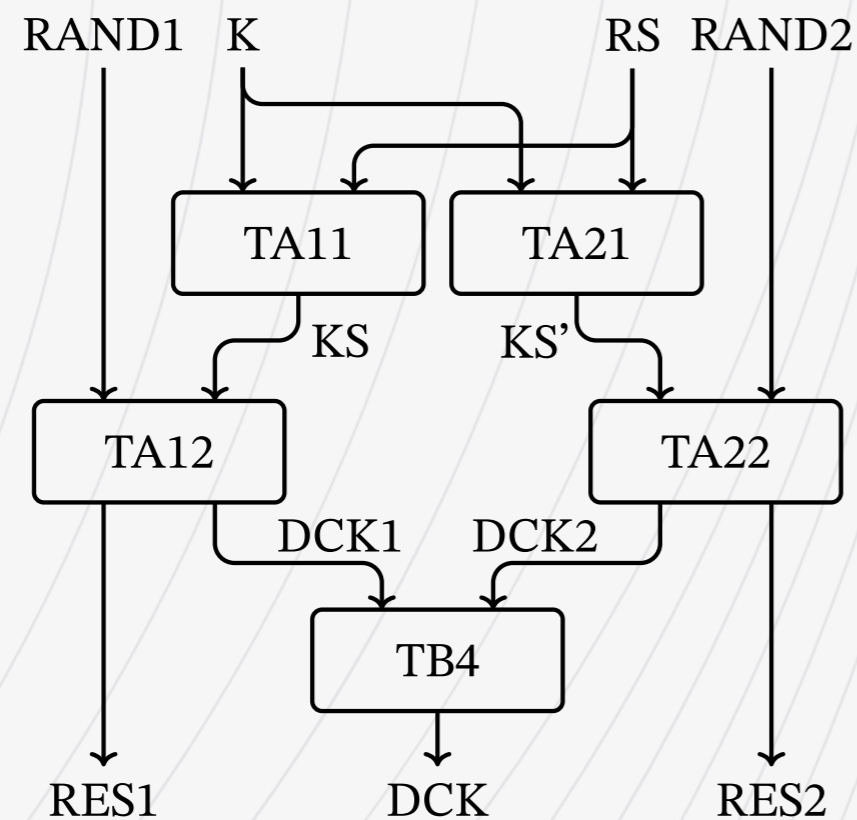

- Protocols in public standard, primitives not. We recovered:
- All TAx<sub>x</sub> based on **HURDLE\*** cipher
  - 16-round Feistel cipher
  - 64-bit blocks, 128-bit key
- All TB<sub>x</sub> based on XOR / addition
- Some blocks identical / related
  - TA11 = TA41
  - TA12 = TA22
  - TA11(K, RS) = TA21(K, reversed(RS))

\* <https://impact.ref.ac.uk/casestudies/CaseStudy.aspx?Id=30193>

# CVE-2022-24400 DCK pinning attack

- Mutual authentication

- Shared long-term secret K
- Random seed RS
- Challenge-response (RANDx/RESx)
- Session key DCK

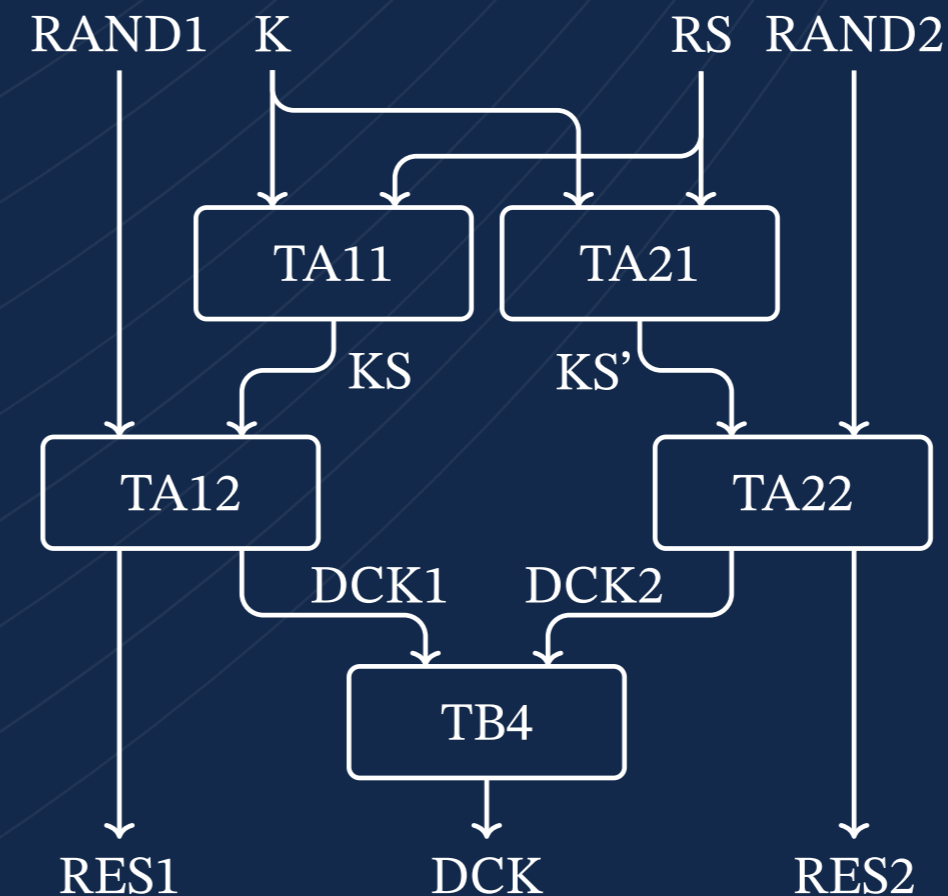

$$\text{DCK} = \text{TB4}(\text{TA12}(\text{TA11}(K, \text{RS}), \text{RAND1}), \text{TA22}(\text{TA21}(K, \text{RS}), \text{RAND2}))$$

# CVE-2022-24400 DCK pinning attack

- We can simplify the authentication procedure now that we know primitives

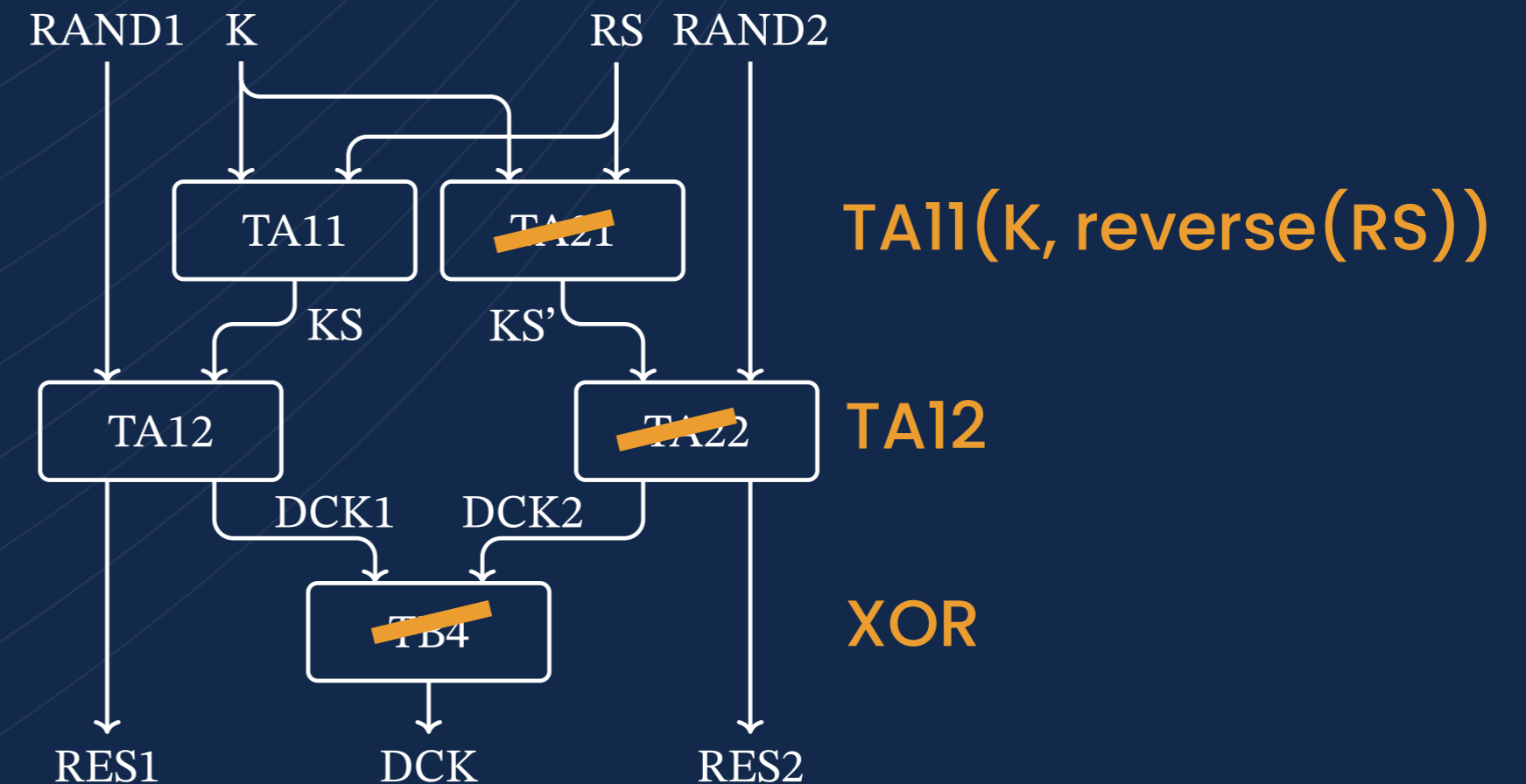

$$DCK = TB4(TA12(TA11(K, RS), RAND1), TA22(TA21(K, RS), RAND2))$$

equals

$$DCK = TA12(TA11(K, RS), RAND1) \wedge TA12(TA11(K, reversed(RS)), RAND2)$$

# CVE-2022-24400 DCK pinning attack

- Assume we impersonate infrastructure and:

- reversed(RS) = RS (“palindrome”)
- Predict MS challenge RAND2, use it as RAND1 as well

- Then, DCK simplifies to:

$$\text{DCK} = \text{TA12}(\text{TA11}(K, \text{RS}), \text{RAND2}) \wedge \text{TA12}(\text{TA11}(K, \text{RS}), \text{RAND2})$$

equals

$$\text{DCK} = \text{XOR}(X, X) = 0 \leftarrow \text{ALL ZERO KEY}$$

- Authenticated channel with radio, intercept uplink, post-auth functionality, etc.



# Identity encryption

- Part of TAA1, called TA61
- Encrypts 24-bit TETRA addresses
  - $\text{encrAddr} = \text{TA61}(\text{addr})$
- Pseudonymity, not anonymity
  - Encrypted identities change only when network key changes
- *Implementation disclosed in December..*
  - *Following serious concerns raised by stakeholders*



# CVE-2022-24403 De-anonymization

- **Intermediate secret  $c$  is derived from CCK using HURDLE**
  - Full details in December
- **TA61 is vulnerable to *meet-in-the-middle* attack**
  - Recovers value of  $c$
  - Complexity:  $2^{48}$  with 3 identity pairs
  - 1 min on laptop
  - Then, **instant deanonymization**
- **Also: attack on HURDLE could be catastrophic now...**
  - **CCK recovery?**

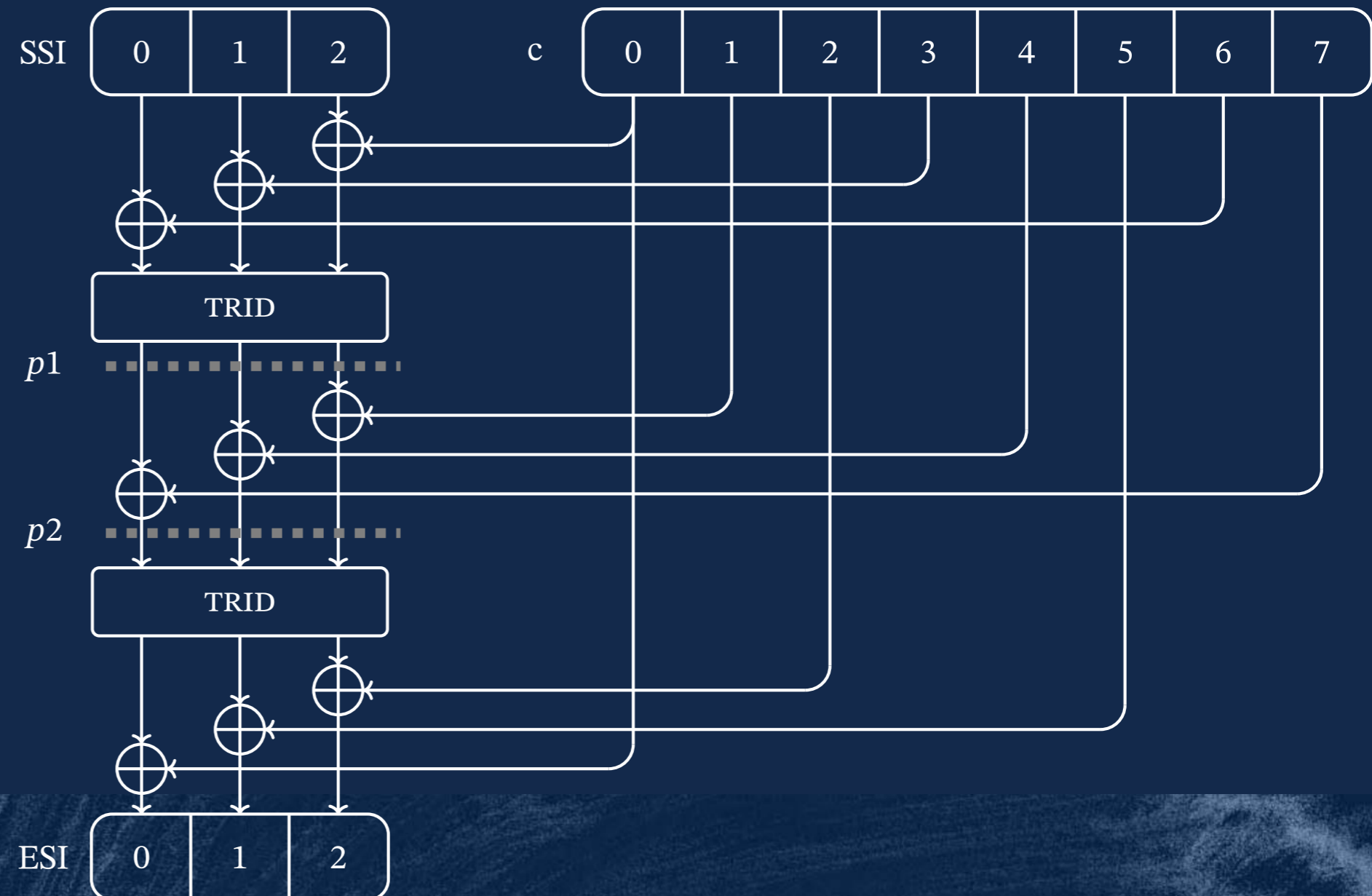





# De-anonymization Scenario

- **Contextualize**
  - Correlate identities with observed units
  - Identity ranges allocated to user groups
- **Build live tracking map**
  - **Counter-intelligence** (unmask covert surveillance units)
  - **Early warning** (of e.g. police intervention)
- **Convenient**
  - Raspberry Pi + RTL-SDR dongle can be spread for geographic coverage
  - **Fully passive, so stealthy!**



# TEA Keystream generators

- Used for air interface encryption
- All KSGs have similar structure
- TEA2 seems robust\*
  - We are not cryptographers
  - Public scrutiny needed!

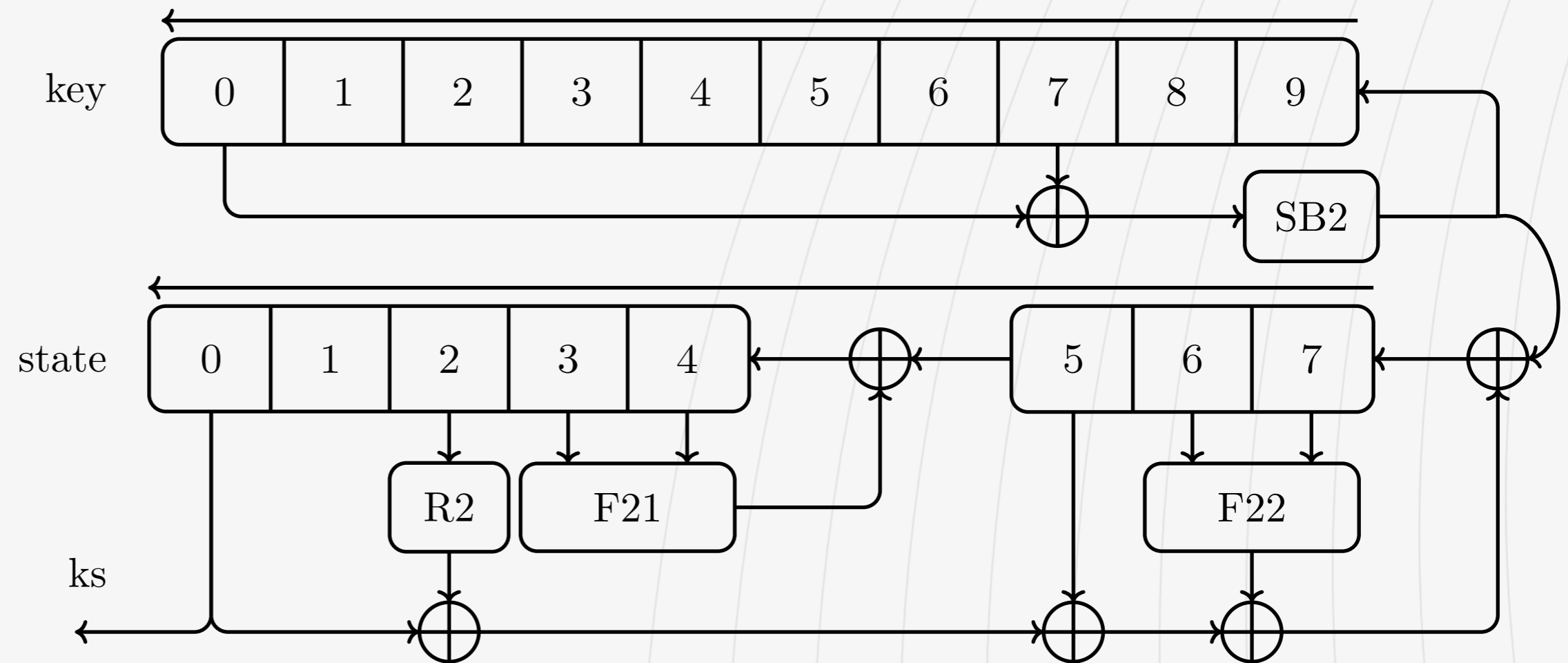

Pictured: TEA2

# CVE-2022-24402

## TEA1 backdoor

- Target audience
  - Private security, "less friendly" police / mil
  - .. But also, power, water, oil & gas
- Advertised with 80-bit key
  - Readily exportable but no hard indication on actual security (56-bit? 40-bit? 32-bit?)
- Has "key initialization" function
  - Reduces 80-bit key into 32-bit register
- Trivial passive brute force (<1min)
  - Intercept comms
  - Inject data (SCADA WAN!)

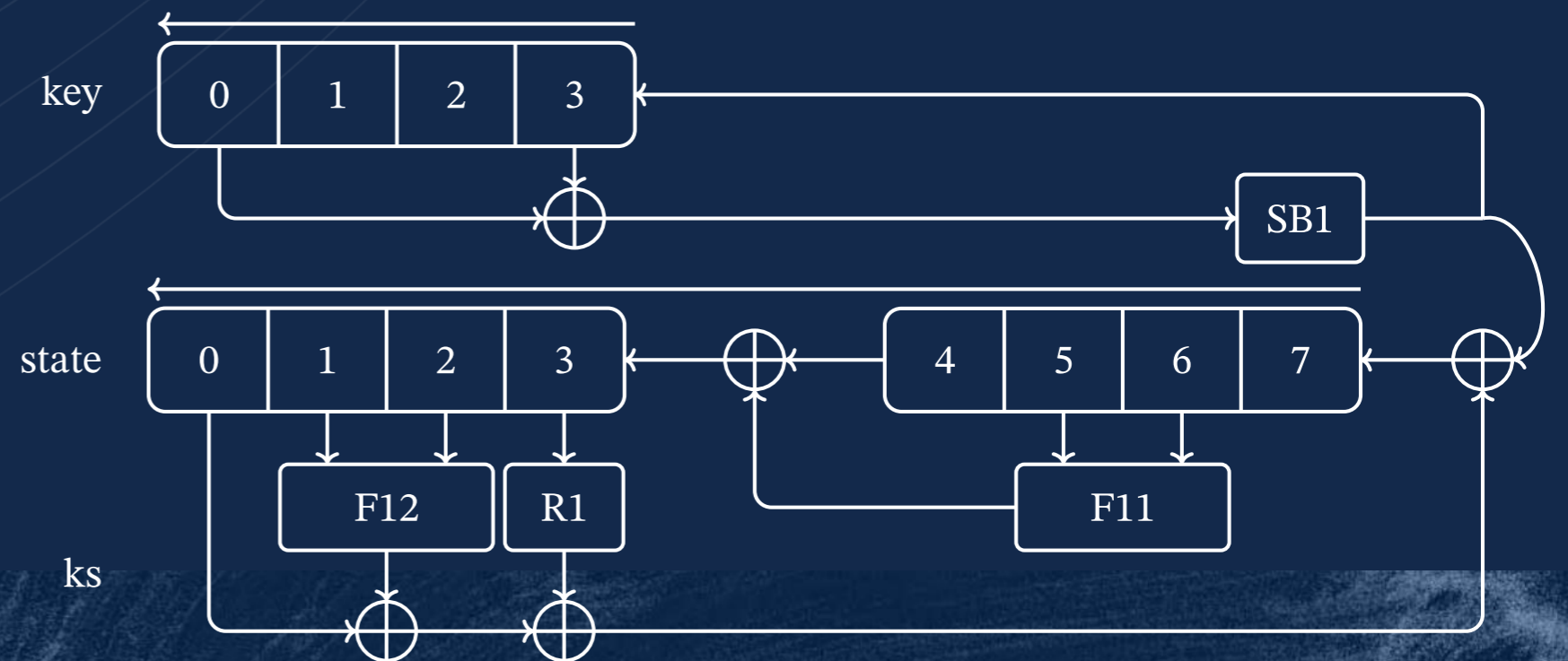
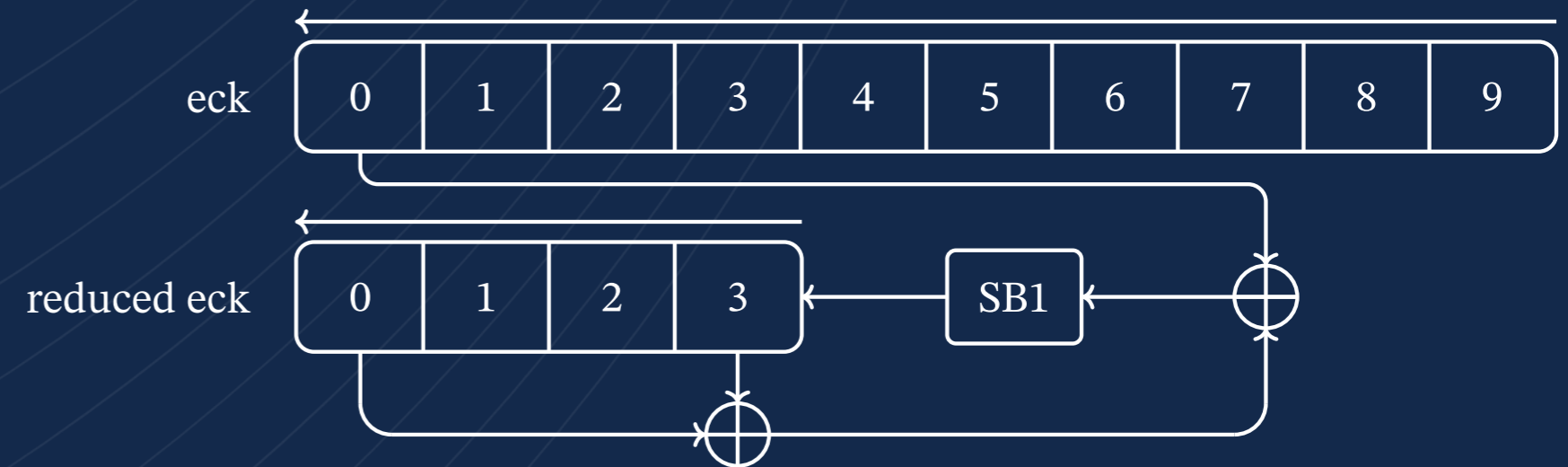

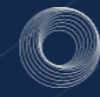

# Demo: CVE-2022-24402

## TEA1 Attack



# NVIDIA GTX 1080

State-of-the-art... consumer hardware... in 2016...



“**BM:** The researchers found that they were able to decrypt messages from this, using a **very high-powered graphics card** in about a minute.”<sup>1</sup>

“**BM:** I suppose all I can say is that **25 years ago the length of this algorithm was probably sufficient to withstand brute-force attacks.**

**KZ:** You’re saying 25 years ago 32 bit would have been secure?

**BM:** I think so. I can only assume.”<sup>1</sup>

“**BM:** I would say it’s vulnerable if you happen to be an expert and have some **pretty reasonable equipment.**”<sup>1</sup>

<sup>1</sup> Interview between Kim Zetter and Brian Murgatroyd, Chair of ETSI TC TETRA  
<https://zetter.substack.com/p/interview-with-the-etsi-standards>



- **Let's not assume**



- **Let's not assume**
- **Let's not use reasonable equipment**



# Toshiba Satellite 4010CDS



- Let's not assume
- Let's not use reasonable equipment
- Let's go back to 1998!
  - 266 MHz Pentium II
  - 4.1 billion byte hard disk
  - 32MB SDRAM





# Demo: Party like the '90s

# Air Interface Encryption

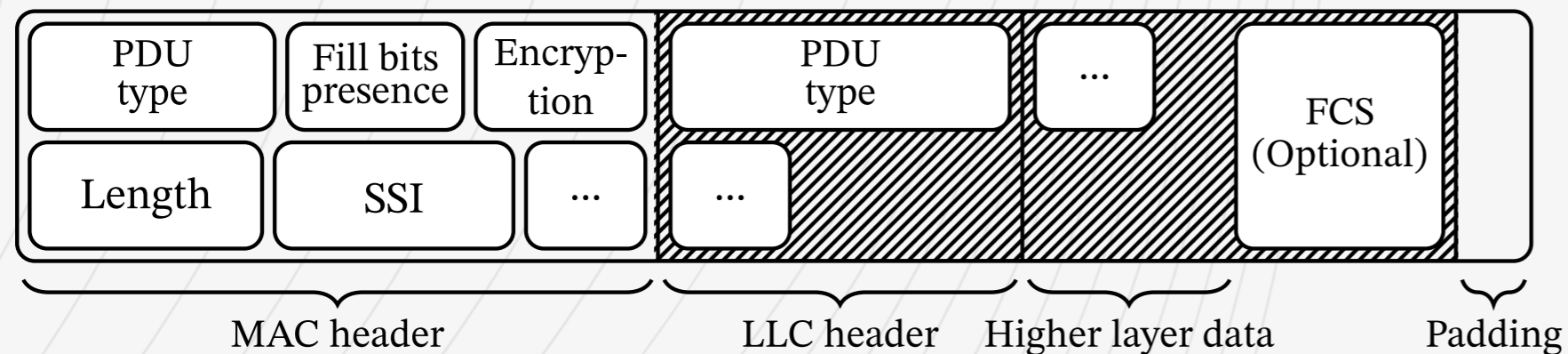

- Air interface signalling is encrypted
- MAC header is unencrypted\*
- LLC header and further payload gets encrypted by TEAx keystream generator (KSG)
- **TETRA messages have no cryptographic auth/integrity guarantee**
  - CRC16 on lower MAC layer
  - Optional CRC32 on LLC layer

# Air Interface Encryption

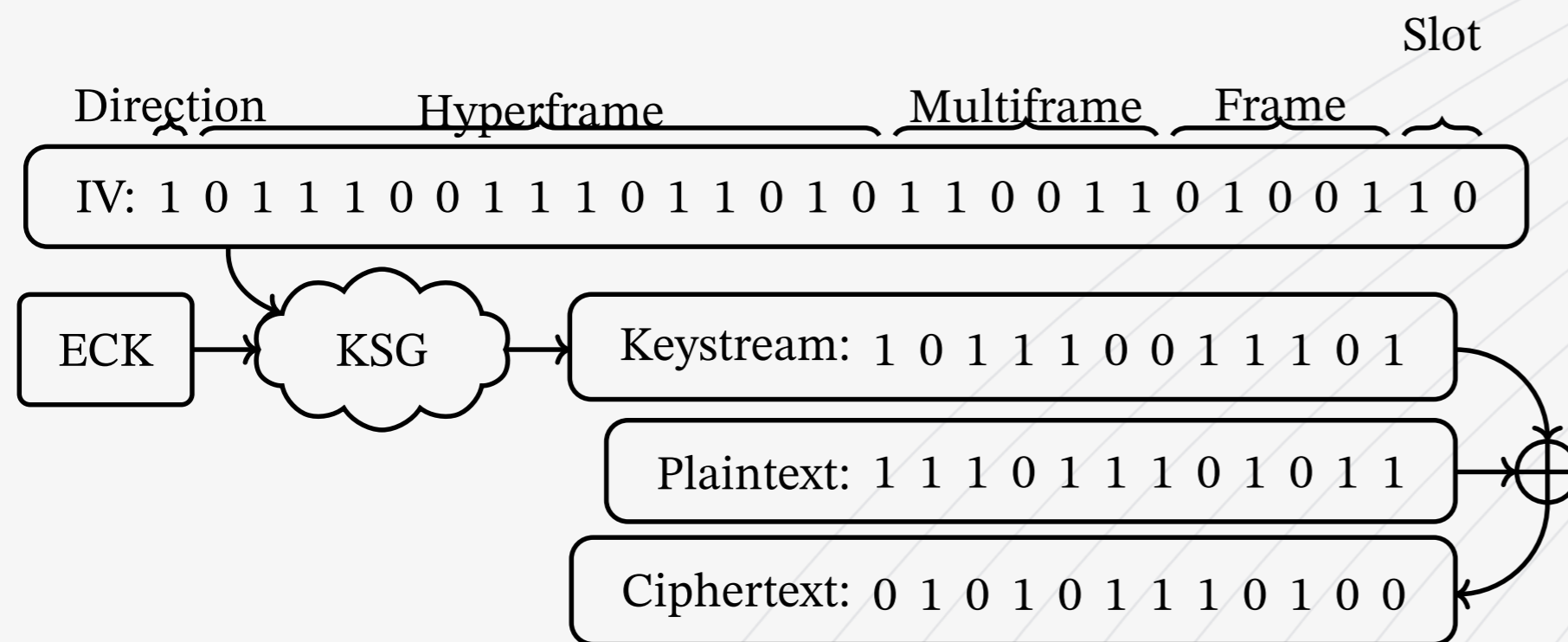

- TEAx keystream generators depend on key and on network time
  - Need to guarantee different keystream is used each time
- Network time broadcast in unencrypted, unauthenticated manner
  - SYNC and SYSINFO frames
- As mentioned; no further cryptographic integrity checks
  - Any encrypted data is taken at face value

# CVE-2022-24401

## Keystream

### recovery attack

- Attacker can overpower infrastructure and **alter MS perception of time**
- MS will then use keystream that fits the attacker specified network time
- **Works regardless of TEA used, regardless of 'network authentication'**

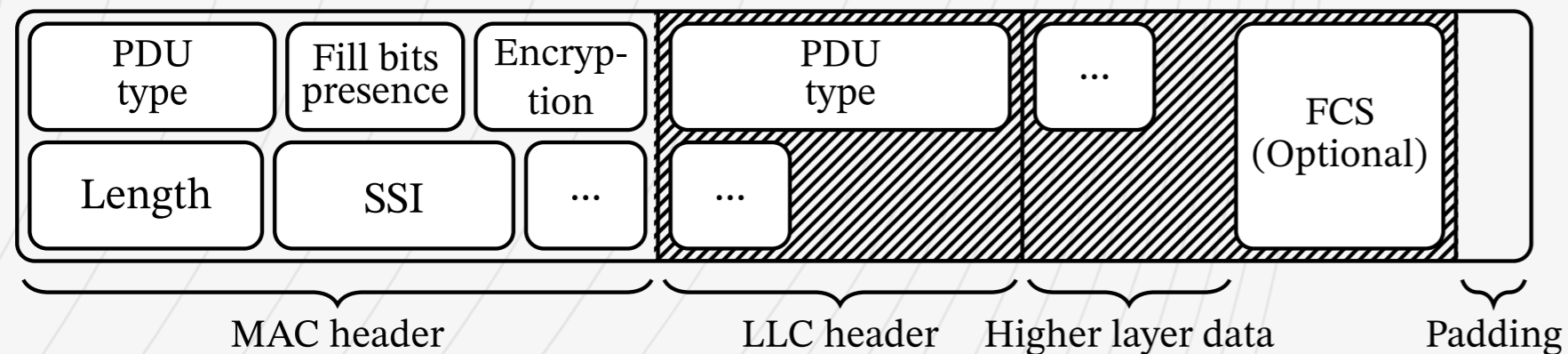

# Attack outline

## Attack outline:

- Capture interesting encrypted message at time T
- Target MS (any, with same keys)
- Overpower legitimate signal
- Set MS time to time T
- *Somehow recover keystream for that time*
- ...
- Profit

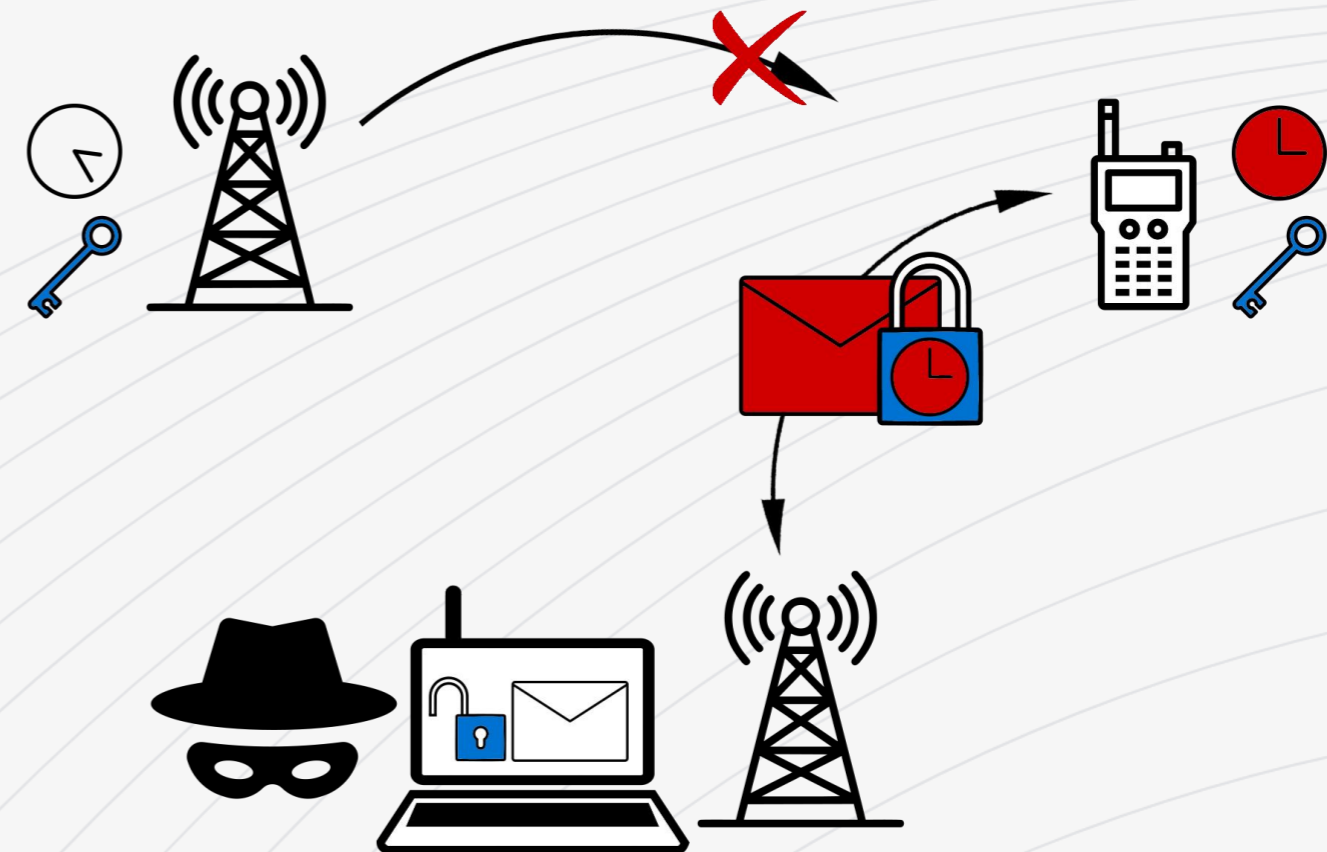

# Recovering keystream

- Assume we have  $n$  bits of keystream for time  $t$ . Construct message such that:
  - It is of length  $n+1$
  - It has an FCS
  - It needs an ACK from the MS
- Encrypt, guess last  $k_s$  bit is zero
- Send to MS
- If MS ACKs: FCS was good
  - Found keystream bit  $n+1 = 0$
  - If no ACK: keystream bit  $n+1 = 1$
- Repeat

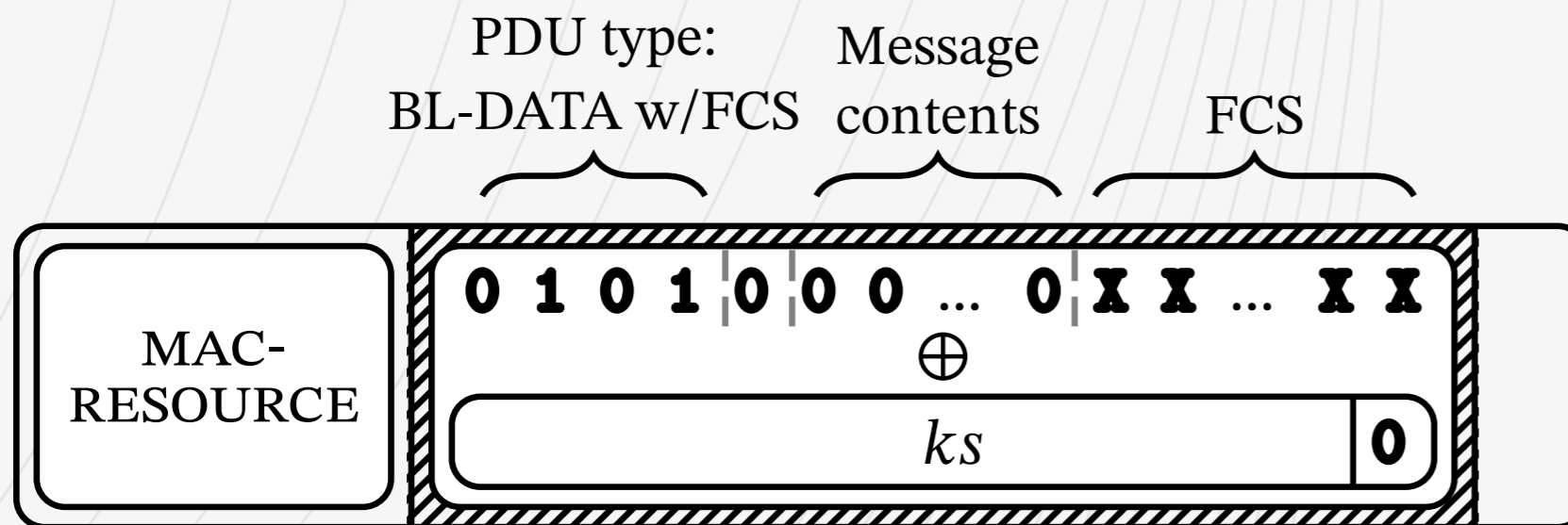



# Bootstrap

- **We need *seed keystream***
- **Send 16 messages**
  - 00000, 00010, ..., 11110
  - Will be decrypted by MS
- **Only one will get ACK from MS**
  - BL-DATA w/o FCS
  - Other messages are longer or unACKed
- **Recovered 4 bits of ks 😊**

# From 4 to 37 bits

- Recover 4 bits for 10 slots
- Craft aforementioned message with FCS (min 37 bits)
- Use MAC fragmentation to distribute over the 10 slots
- Grow keystream knowledge for any slot of interest by guessing next ks bit







# Intermezzo: ETSI

- “Theoretical attack”
- Okay, so, can we have a base station to prove practicality?
  - Haha lol no
  - More stakeholders responded like this
- What do we do now?
  - Implement TETRA infra stack for SDR?
  - Sounds like a lot of work...



# There's your PoC

- Bought old Motorola MBTS
- Found some vulns in it
- Wrote module framework for it
- Turned it into attack platform 🐛





# Demo: CVE-2022-24401

## Keystream recovery attack



# ETSI's response?

“The research uncovered some general areas for improvement in the TETRA protocol”<sup>1</sup>

<sup>1</sup> ETSI and TCCA Statement to TETRA Security Algorithms Research Findings Publication on 24 July 2023  
<https://www.etsi.org/newsroom/news/2260-etsi-and-tcca-statement-to-tetra-security-algorithms-research-findings-publication-on-24-july-2023>



# Coordinated Vulnerability Disclosure



# Timeline





# Mitigations

CVE	Description	Recommended Mitigation	Compensating Controls
<a href="#">CVE-2022-24401</a> <a href="#">CVE-2022-24404</a>	Keystream recovery attack	<ul style="list-style-type: none"> <li>Firmware updates</li> <li>E2E</li> <li>(data) TLS / IPsec</li> </ul>	<ul style="list-style-type: none"> <li>Renew keys frequently</li> <li>Risk assessment, adjust OPSEC</li> </ul>
<a href="#">CVE-2022-24402</a>	TEA1 backdoor	<ul style="list-style-type: none"> <li>TEA2</li> <li>E2E</li> <li>(data) TLS / IPsec</li> </ul>	<ul style="list-style-type: none"> <li>Assume TEA1 == cleartext</li> <li>Risk assessment, adjust OPSEC</li> </ul>
<a href="#">CVE-2022-24403</a>	Deanonymization attack	<ul style="list-style-type: none"> <li>Migrate to TAA2</li> </ul>	<ul style="list-style-type: none"> <li>Risk assessment, adjust OPSEC</li> </ul>
<a href="#">CVE-2022-24400</a>	DCK key pinning attack	<ul style="list-style-type: none"> <li>Firmware updates</li> <li>E2E</li> <li>Migrate to TAA2</li> </ul>	<ul style="list-style-type: none"> <li>Disable radios with unacceptable FW update rollout timelines</li> </ul>





TETRA  BURST

# Aftermath



# Hold on...

“**BM:** And I would expect that anybody ... who need a lot of protection would not just be using TEA1. Within Europe... I would suggest that anyone who needed high security would be using TEA2. .... The problems generally are that TEA2 is only licensed for use within Europe by public safety authorities.”<sup>1</sup>

- **What’s this “Europe” you speak of?**
  - Poland, Bulgaria, Croatia, Montenegro, Moldova
  - All (candidate) EU states
- **Allowed to use TEA2 according to ETSI’s own standards<sup>4</sup>**
  - As far back as 2003 or 2008
- **Yet...**
  - **Tenders show TEA1 equipment was procured by *all* for police/military in last 5 years<sup>2,3</sup>...**

<sup>1</sup> Interview between Kim Zetter and Brian Murgatroyd, Chair of ETSI TC TETRA  
<https://zetter.substack.com/p/interview-with-the-etsi-standards>

<sup>2</sup> <https://www.volkskrant.nl/nieuws-achtergrond/overheid-weet-al-dertig-jaar-van-achterdeur-in-beveiliging-radiocommunicatie~bcefc760/>

<sup>3</sup> <https://www.o2.pl/informacje/niepokojace-informacje-luka-w-systemie-tetra-niech-ktos-cos-zrobi-6923376203832288a>

<sup>4</sup> [https://www.etsi.org/deliver/etsi\\_tr/101000\\_101099/10105302/02.01.01\\_60/tr\\_10105302v020101p.pdf](https://www.etsi.org/deliver/etsi_tr/101000_101099/10105302/02.01.01_60/tr_10105302v020101p.pdf)

[https://www.etsi.org/deliver/etsi\\_tr/101000\\_101099/10105302/02.02.02\\_60/tr\\_10105302v020202p.pdf](https://www.etsi.org/deliver/etsi_tr/101000_101099/10105302/02.02.02_60/tr_10105302v020202p.pdf)

[https://www.etsi.org/deliver/etsi\\_ts/101000\\_101099/10105302/02.03.01\\_60/ts\\_10105302v020301p.pdf](https://www.etsi.org/deliver/etsi_ts/101000_101099/10105302/02.03.01_60/ts_10105302v020301p.pdf)



# Maybe nobody targets TETRA networks?

**“KZ:** But is that in the best interest of the public that are using these algorithms?

**BM:** Well it’s a moot point isn’t it, really. That’s a difficult thing to say “yes it’s to the benefit of the public or not.” **There’s no evidence of any attacks on ... TETRA that we know of.”**<sup>1</sup>

“ETSI and TCCA are not at this time aware of any exploitations on operational networks.”<sup>2</sup>

**2 out of 5 attacks are passive so...** 

<sup>1</sup> Interview between Kim Zetter and Brian Murgatroyd, Chair of ETSI TC TETRA  
<https://zetter.substack.com/p/interview-with-the-etsi-standards>

<sup>2</sup> ETSI and TCCA Statement to TETRA Security Algorithms Research Findings Publication on 24 July 2023  
<https://www.etsi.org/newsroom/news/2260-etsi-and-tcca-statement-to-tetra-security-algorithms-research-findings-publication-on-24-july-2023>



# Right...

Snowden leaks show joint NSA & ASD project to collect Indonesian police TETRA comms during U.N. climate change conf in Bali 2007<sup>1</sup>

Not proof of TETRA:BURST exploitation specifically – but proof of active TETRA targeting

TOP SECRET//COMINT//REL TO USA, FVEY//20320108

## (S//SI//REL) SIGDEV Efforts in Support of the United Nations Framework for Climate Change Conference, Bali, Indonesia

POCs: [REDACTED]



(U) The United Nations Framework Climate for Change Conference (UNFCCC), held in Bali, Indonesia from 3-14 December, was attended by 10,000 conferees, activists, journalists, and high ranking representatives from 190 countries, including the newly elected Australian Prime Minister, Mr. Kevin Rudd, the U.S. Secretary of State, and former U.S. Vice President Al Gore.



(S//SI//REL) Beginning on 29 November, the SIGDEV and Collection Operations Divisions executed a self-initiated network development effort, in coordination with the Defense Signals Directorate (DSD) and site leadership, in support of this target. The goal of the development effort was to gain a solid understanding of the network structure should collection be required in the event of an emergency. This involved identifying systems in use, isolating talk groups and TETRA towers of highest interest, determining network hierarchy, and reporting flow. Site produced a Telecommunications Information Report (TELIR) documenting network structure and activity. (Please contact [REDACTED] if you would like a copy of the TELIR.)

(S//SI//REL) Although DSD's initial collection requirements were only for UHF push-to-talk communications collected via remote operations in Canberra, RAINFALL proposed a more in-depth SIGDEV effort. To start, a communications externals (COMEXT) task was generated to rapidly survey 100–3300MHz. Using this data, site analysis identified a previously unknown TETRA trunk mobile network with towers in both Jakarta and Bali. With this information, site analysts began a focused TETRA network development effort, which resulted in the identification of Indonesian security forces (POLRI) communications at both locations. At DSD's request, site dedicated a staff member (a trained Indonesian linguist) to this effort to monitor, scan, and transcribe the TETRA voice communications in order to provide daily summaries of network activity. Intercept ranged from network set-up to situation reports. Highlights include the compromise of the mobile phone number for Bali's Chief of Police and demonstration routes.

<sup>1</sup> <https://theintercept.com/document/nsa-telegraph-sigdev-efforts-in-support-of-the-united-nations-framework-for-climate-change-conference-bali-indonesia/> midnightblue.nl

# Right...

Op QUITO (TSI): Following a couple OMGs and a significant amount of prep work, the planning phase of Op QUITO, an effects op to support FCO's goals relating to Argentina and the Falkland Islands, is almost complete. The plans are due to go to submission in the next month, and then this will hopefully lead to a long-running, large scale, pioneering effects operation.

Snowden leaks reveal GCHQ TSI '*effects operation*' QUITO against AR around Falklands/Malvinas oil exploration rights tensions in 2009<sup>1</sup>

Involved TETRA collects as part of military/leadership tasking

Not proof of TETRA:BURST exploitation specifically – but proof of *active TETRA targeting*

## Argentina

TSI initiated and supported OH tasking against Argentina in efforts to collect high priority military and Leadership comms. Work was coordinated across the OH enterprise to obtain results when opportunity arose using US 903G and US 940C, MHS Ops were a main driver for this collection. Results included a number of TETRA collects and at least seven Argentinian PCM (digital) microwave emitters which were processed and geolocated. Although TSI haven't got desired results on their comms of interest as yet, this was a positive and encouraging team effort against this target in readiness for when next opportunity arises. Efforts between TSI and MHS continue.

<sup>1</sup> <https://cryptome.org/2015/04/nsa-gchq-jtrig-intercept-15-0402.pdf>



# What's next?

- **ETSI announced update to standard**
  - TAA1 → TAA2
  - TEA{1,3} → TEA{5,7}
  - Keystream recovery mitigation\*
- **Again: secret algorithms<sup>2</sup>!**

**KZ:** If you're saying that the only reason they're secret is because the government has advised it, can ETSI decide on its own to make them public?

**BM:** I'd have to say yes.

**KZ:** So why don't you?

**BM:** **I don't know.**<sup>1</sup>

The specification for TEA6 consists of the following three parts:

- |         |                                   |
|---------|-----------------------------------|
| Part 1: | Algorithm specification;          |
| Part 2: | Design conformance test data;     |
| Part 3: | Algorithm input/output test data. |

The procedures described in the present document apply to Parts 1 and 2 of the specifications. Parts 1 and 2 are confidential for each of the algorithms.



# Should we trust TEA6/7?

What do you think?



# Should we trust TEA6/7?

Let's ask ETSI!

**KZ: Should we trust ETSI algorithms going forward?**

**BM:** I've no reason to believe you shouldn't.

**KZ:** But the public has a reason not to — the fact that they're secret.

**BM:** I can think of all sorts of algorithms that, over time, they become weak. And lots of them have been public ones as well. Sure, algorithm may not have a life of a quarter of a century that's for sure.... [But] **we have no reason to produce dodgy algorithms, if you like.**<sup>1</sup>

**BM:** We were just given those algorithms. **And the algorithms were designed with some assistance from some government authorities, let me put it that way.**<sup>1</sup>

**BM:** **At the end of the day, it's down to the customer organization to ensure that things are secure enough for them. Now, I agree that's difficult with a private algorithm.** The manufacturer knows the length of the key, but it's not publicly available. **But the reason we have three different algorithms available must be clear to somebody that they're not all as secure as each other.**<sup>1</sup>

<sup>1</sup> Interview between Kim Zetter and Brian Murgatroyd, Chair of ETSI TC TETRA

<https://zetter.substack.com/p/interview-with-the-etsi-standards>

NOTE: BM's comments refer to TEA1-4 but there is little reason to doubt their applicability to TEA5-7



# Conclusion

- First public, in-depth TETRA security analysis (after 20+ years)
- Secret crypto algorithms reverse-engineered
- Multiple vulnerabilities uncovered (incl. backdoor)
- Implications for voice, data, and SCADA
- Patches available for some issues, mitigations for others

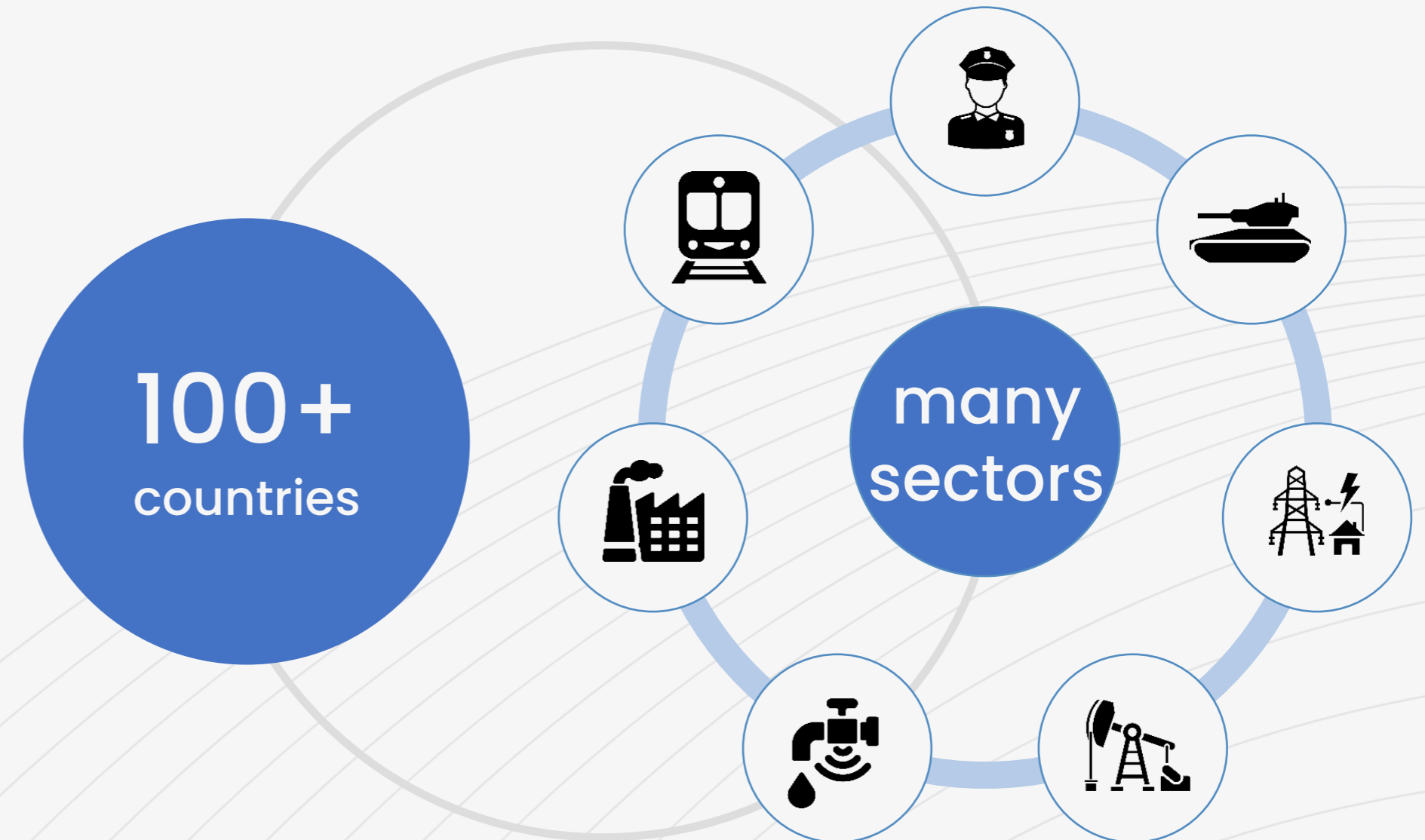



# Call to Action

1. Take a closer look at the TEAs
  - Especially the TEA3 **S-Box!**
2. Take a closer look at HURDLE
  - An attack on HURDLE could be **catastrophic** due to attack on TA61
3. Implement / extend **open TETRA stacks**
  - Great work by OsmocomTETRA / SQ5BPF
  - .. Still lots to do, talk to NLnet, OsmocomTETRA
- 4. Stop doing secret crypto please**
  - Looking at you, **TEA{5,6,7} / TAA2...**
  - Also looking at you, TETRA **E2EE...**



# Questions?

## Social



## Web

- [midnightblue.nl](https://midnightblue.nl)
- [tetraburst.com](https://tetraburst.com)

## Contact

- [c.meijer@midnightblue.nl](mailto:c.meijer@midnightblue.nl)
- [w.bokslag@midnightblue.nl](mailto:w.bokslag@midnightblue.nl)
- [j.wetzels@midnightblue.nl](mailto:j.wetzels@midnightblue.nl)

