

TYPICAL OPERATION (cont'd)

Maximum-Signal DC Collector Current	$I_C(\max)$	-0.85	A
Input Impedance of Stage (per base)		65	Ω
Load Impedance (speaker voice-coil)	R_L	4	Ω
Maximum Collector Dissipation (per transistor) under worst-case conditions		7.5	W
EIA Music Power Output Rating		25	W
Power Gain		31	dB
Maximum-Signal Power Output	P_{OM}	15	W
Total Harmonic Distortion at Maximum-Signal Power Output		5	%

2N2205

COMPUTER TRANSISTOR

Si n-p-n double-diffused epitaxial planar type used in high-speed switching applications in military and industrial equipment where high reliability and high packaging densities are essential. JEDEC TO-18, Outline No.9. Terminals: 1 - emitter, 2 - base, 3 - collector and case.

MAXIMUM RATINGS

Collector-to-Base Voltage	V_{CBO}	25	V
Collector Current	I_C	0.2	A
Transistor Dissipation: $T_A = 25^\circ\text{C}$	P_T	0.3	W
Temperature Range: Operating (Ambient)	$T_A(\text{opr})$	-65 to 175	$^\circ\text{C}$

CHARACTERISTICS

Collector-to-Base Breakdown Voltage ($I_C = 0.1$ mA, $I_E = 0$)	$V_{(BR)CBO}$	25 min	V
Collector-to-Emitter Saturation Voltage ($I_C = 50$ mA, $I_B = 5$ mA)	$V_{CE(\text{sat})}$	0.35 max	V
Collector-Cutoff Current ($V_{CB} = 15$ V, $I_E = 0$)	I_{CBO}	0.025 max	μA
Static Forward-Current Transfer Ratio ($V_{CE} = 1$ V, $I_C = 10$ mA)	h_{FE}	20 min	
Output Capacitance ($V_{CB} = 10$ V, $I_E = 0$, $f = 0.14$ MHz)	C_{obo}	6 max	pF
Turn-On Time ($V_{CE} = 3$ V, $I_C = 10$ mA, $I_{B1} = 3$ mA, $I_{B2} = -1$ mA)	$t_d + t_r$	40 max	ns
Turn-Off Time ($V_{CE} = 3$ V, $I_C = 10$ mA, $I_{B1} = 3$ mA, $I_{B2} = -1$ mA)	$t_s + t_f$	75 max	ns

2N2270

TRANSISTOR

Si n-p-n triple-diffused planar type used in rf-amplifiers, mixers, oscillators, and converters, and in af small-signal and power amplifiers. JEDEC TO-5, Outline No.3. Terminals: 1 - emitter, 2 - base, 3 - collector and case.

MAXIMUM RATINGS

Collector-to-Base Voltage	V_{CBO}	60	V
Collector-to-Emitter Voltage: $R_{BE} \leq 10 \Omega$	V_{CER}	60	V
Base open	V_{CEO}	45	V
Emitter-to-Base Voltage	V_{EBO}	7	V
Collector Current	I_C	1	A
Transistor Dissipation: T_A up to 25°C	P_T	1	W
T_c up to 25°C	P_T	5	W
T_A or T_c above 25°C	P_T	See curve page 116	
Temperature Range: Operating (Junction)	$T_J(\text{opr})$	-65 to 200	$^\circ\text{C}$
Storage	T_{STG}	-65 to 200	$^\circ\text{C}$
Lead-Soldering Temperature (10 s max)	T_L	255	$^\circ\text{C}$

CHARACTERISTICS (At case temperature = 25°C)

Collector-to-Base Breakdown Voltage ($I_C = 0.1 \text{ mA}$, $I_B = 0$)	$V_{(BR)CBO}$	60 min	V
Emitter-to-Base Breakdown Voltage ($I_E = 0.1 \text{ mA}$, $I_C = 0$)	$V_{(BR)EBO}$	7 min	V
Collector-to-Emitter Sustaining Voltage: $I_C = 100 \text{ mA}$, $t_p = 300 \mu\text{s}$, $df = 1.8\%$	$V_{CEO(SUS)}$	45 min	V
$I_C = 100 \text{ mA}$, $R_{BE} = 10 \Omega$, $t_p = 300 \mu\text{s}$, $df = 1.8\%$	$V_{CER(SUS)}$	60 min	V
Collector-to-Emitter Saturation Voltage ($I_C = 150 \text{ mA}$, $I_B = 15 \text{ mA}$)	$V_{CE(sat)}$	0.9 max	V
Base-to-Emitter Saturation Voltage ($I_C = 150 \text{ mA}$, $I_B = 15 \text{ mA}$)	$V_{BE(sat)}$	1.2 max	V
Collector-Cutoff Current: $V_{CB} = 60 \text{ V}$, $I_E = 0$, $T_C = 25^\circ\text{C}$	I_{CBO}	0.1 max	μA
$V_{CB} = 60 \text{ V}$, $I_E = 0$, $T_C = 150^\circ\text{C}$	I_{CBO}	50 max	μA
Emitter-Cutoff Current ($V_{EB} = 5 \text{ V}$, $I_C = 0$)	I_{EBO}	0.1 max	μA
Pulsed Static Forward-Current Transfer Ratio: ($V_{CE} = 10 \text{ V}$, $I_C = 150 \text{ mA}$, $t_p = 300 \mu\text{s}$, $df = 1.8\%$)	$h_{FE}(pulsed)$	50 to 200	
Static Forward-Current Transfer Ratio ($V_{CE} = 10 \text{ V}$, $I_C = 1 \text{ mA}$)	h_{FE}	35 min	
Small-Signal Forward-Current Transfer Ratio: $V_{CE} = 10 \text{ V}$, $I_C = 5 \text{ mA}$, $f = 1 \text{ kHz}$	h_{fe}	30 to 180	
$V_{CE} = 10 \text{ V}$, $I_C = 50 \text{ mA}$, $f = 20 \text{ MHz}$	h_{fe}	3 min	
Input Capacitance ($V_{EB} = 0.5 \text{ V}$, $I_C = 0$)	C_{iBo}	80 max	pF
Output Capacitance ($V_{CB} = 10 \text{ V}$, $I_E = 0$)	C_{oBo}	15 max	pF
Thermal Resistance, Junction-to-Case	θ_{J-C}	35 max	$^\circ\text{C/W}$
Thermal Resistance, Junction-to-Ambient	θ_{J-A}	175 max	$^\circ\text{C/W}$

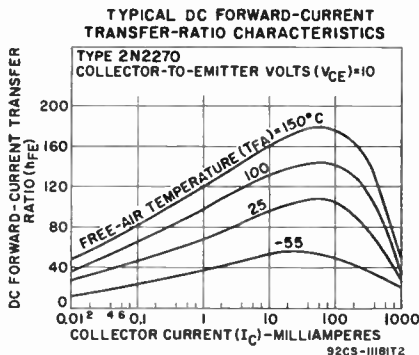

POWER TRANSISTOR

2N2338

Si n-p-n diffused-junction type used in dc-to-dc converters, inverters, choppers, and relay-control circuits; in oscillators and voltage- and current-regulator circuits; and in dc and servo-amplifier circuits. JEDEC TO-36, Outline No.11. Terminals: Lug 1 - base, Lug 2 - emitter, Mounting Stud - collector and case.

MAXIMUM RATINGS

Collector-to-Base Voltage	V_{CBO}	60	V
Collector-to-Emitter Voltage: $V_{BE} = -1.5 \text{ V}$	V_{CEV}	60	V
Base open	V_{CEO}	40	V
Emitter-to-Base Voltage	V_{EBO}	6	V
Collector Current	I_C	7.5	A
Base Current	I_B	5	A
Transistor Dissipation: T_C up to 25°C	P_T	150	W
T_C above 25°C	P_T	See curve page 116	
Temperature Range: Operating (Junction)	$T_J(opr)$	-65 to 200	$^\circ\text{C}$
Storage	T_{STG}	-65 to 200	$^\circ\text{C}$
Lug-Soldering Temperature (10 s max)	$T(lug)$	235	$^\circ\text{C}$

Power Transistors

2N2270

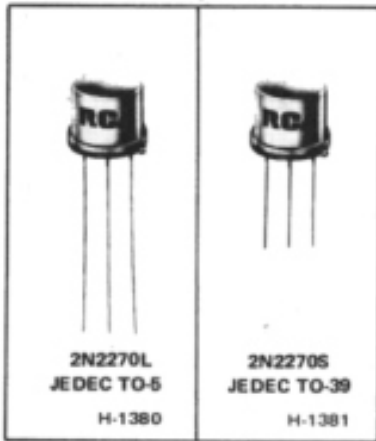

Silicon N-P-N Planar Transistor

General-Purpose Type for Small-Signal, Medium-Power Applications

Features:

- Minimum gain-bandwidth product = 100 MHz; useful in applications from dc to 20 MHz
- Operation at high junction temperatures
- Planar construction for low-noise and low-leakage characteristics
- Very low output capacitance

These devices are available with either 1/8-inch leads (TO-5 package) or 1/16-inch leads (TO-39 package). The longer-lead versions are specified by suffix "L" after the type number; the shorter-lead versions are specified by suffix "S" after the type number.

RCA-2N2270 is a silicon n-p-n planar transistor intended for a wide variety of small-signal and medium-power applications in military and industrial equipment. It features exceptionally

low noise and leakage characteristics, and very low output capacitance.

MAXIMUM RATINGS, Absolute-Maximum Values:

* COLLECTOR-TO-BASE VOLTAGE	V_{CBO}	60	V
COLLECTOR-TO-EMITTER VOLTAGE:			
With external base-to-emitter resistance (R_{BE}) $\leq 10 \Omega$	V_{CER}	60	V
* With base open	V_{CEO}	45	V
* EMITTER-TO-BASE VOLTAGE	V_{EBO}	7	V
* COLLECTOR CURRENT	I_C	1	A
* TRANSISTOR DISSIPATION:	P_T		
At case temperatures up to 25°C		5	W
At case temperatures above 25°C		See Fig. 1	
At free-air temperatures up to 25°C		1	W
At free-air temperatures above 25°C		See Fig. 1	
* TEMPERATURE RANGE:			
Storage and operating (Junction)		-65 to +200	°C
* LEAD TEMPERATURE (During soldering):			
At distance $\geq 1/16$ in. (1.58 mm) from seating plane for 10 s max		230	°C

* In accordance with JEDEC registration data format (JS-6 RDF-1)

ELECTRICAL CHARACTERISTICS, At Case Temperature (T_C) = 25°C unless otherwise specified

CHARACTERISTIC	SYMBOL	VOLTAGE V			CURRENT mA			LIMITS		UNITS
		V _{CB}	V _{CE}	V _{EB}	I _C	I _E	I _B	MIN.	MAX.	
Collector Cutoff Current: With emitter open At $T_C = 150^\circ\text{C}$	I _{CBO}	60				0		–	0.05	μA
		60				0		–	50	
Emitter Cutoff Current	I _{EBO}			5	0			–	0.1	μA
Collector-to-Base Breakdown Voltage	V _{(BR)CBO}				0.05 μA	0		60	–	V
Emitter-to-Base Breakdown Voltage	V _{(BR)EBO}				0	0.1		7	–	V
Collector-to-Emitter Sustaining Voltage: With external base-to- emitter resistance (R _{BE}) = 10 Ω	V _{CE(sus)}				100 ^a			60	–	V
With base open	V _{CEO(sus)}				100 ^a	0		45	–	
Collector-to-Emitter Saturation Voltage	V _{CE(sat)}				150 ^a		15	–	0.9	V
Base-to-Emitter Saturation Voltage	V _{BE(sat)}				150 ^a		15	–	1.2	V
DC Forward Current Transfer Ratio	h _{FE}		10 10		150 ^a 1			50 30	200 –	
Small-Signal Forward Current Transfer Ratio: f = 1 kHz f = 20 MHz	h _{fe}		10 10		5 50			50 5	275 –	
Gain-Bandwidth Product	f _T		10		50			100	–	MHz
Noise Figure: Generator resistance (R _G) = 1 kΩ Circuit bandwidth (BW) = 1 Hz f = 1 kHz	NF		10 (V _{CC})		0.3			–	10	dB
Output Capacitance	C _{ob}	10				0		–	15	pF
Input Capacitance	C _{ib}			0.5	0			–	80	pF
Saturated Switching Time (See Fig. 8)	t _d +t _r +t _s +t _f							–	30	ns
Thermal Resistance: Junction-to-case	R _{θJC}							–	35	°C/W
Junction-to-free air	R _{θFA}							–	175	

^a In accordance with JEDEC registration data format (JS-6 RDF-1)

^a Pulsed: Pulse duration = 300 μs; duty factor = 1.8%

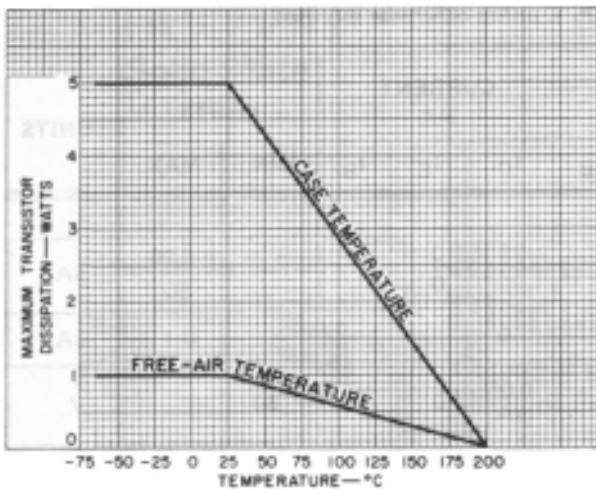

Fig. 1 - Rating chart.

92CS-1172R1

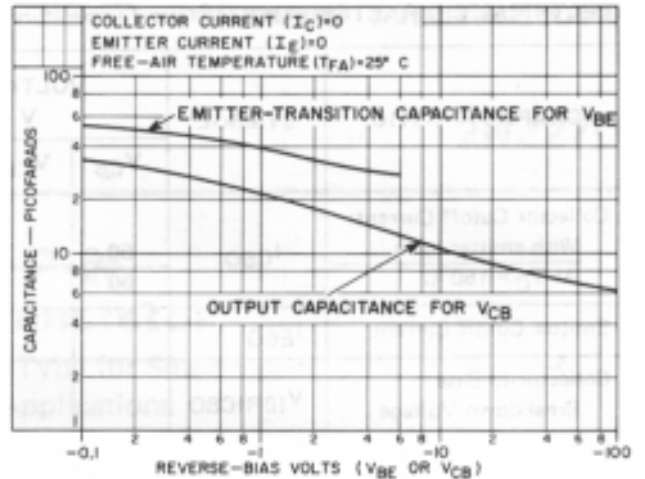

Fig. 2 - Typical emitter-transition-capacitance and output-capacitance characteristics.

92CS-11195

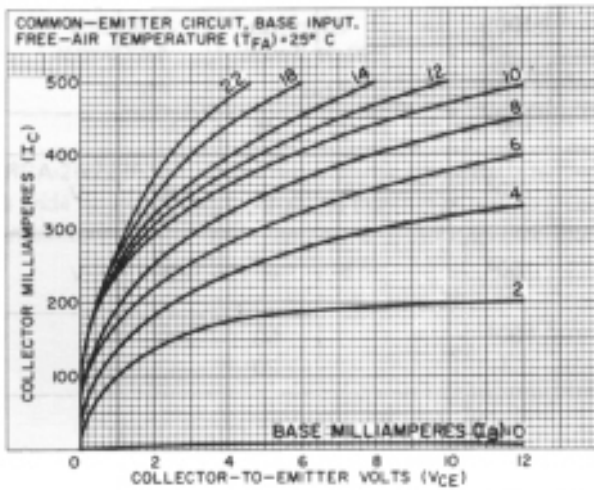

Fig. 3 - Typical collector characteristics.

92CS-11189

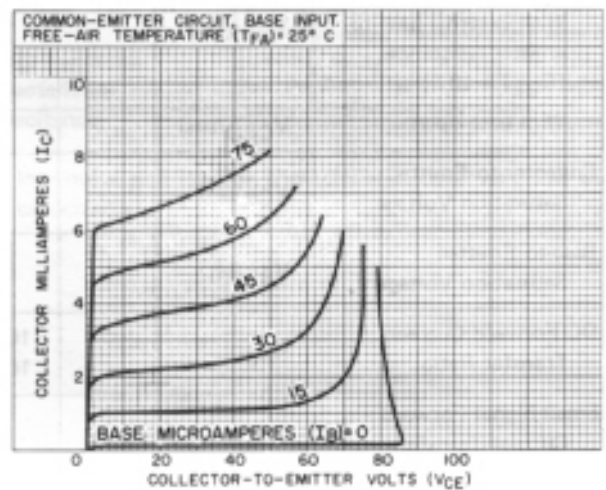

Fig. 4 - Typical collector characteristics.

92CS-1175R1

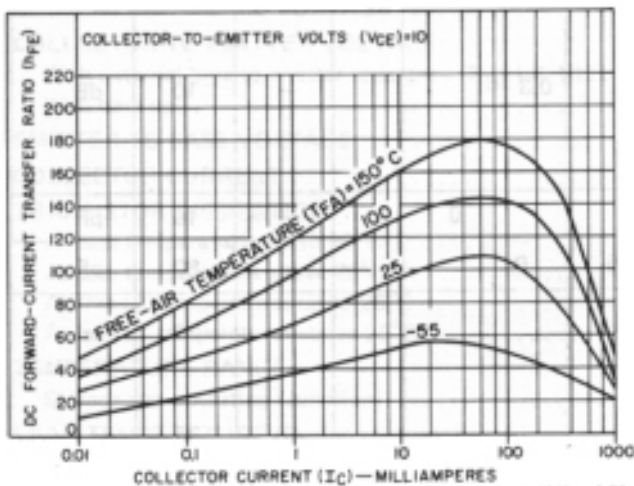

Fig. 5 - Typical dc forward-current transfer ratio characteristics.

92CS-1181R2

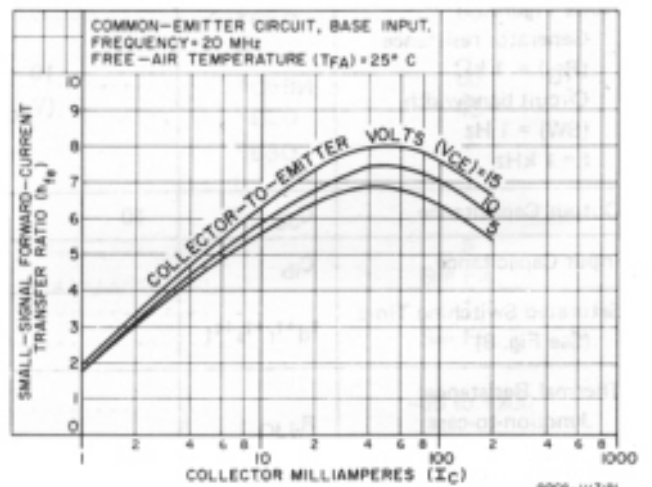
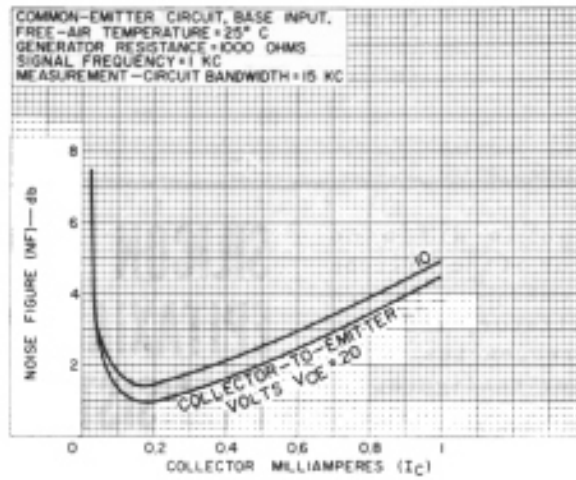

Fig. 6 - Typical small-signal forward-current transfer ratio characteristics.

92CS-11171R1



92CS-1179R1

Fig. 7—Typical of noise-figure characteristics.

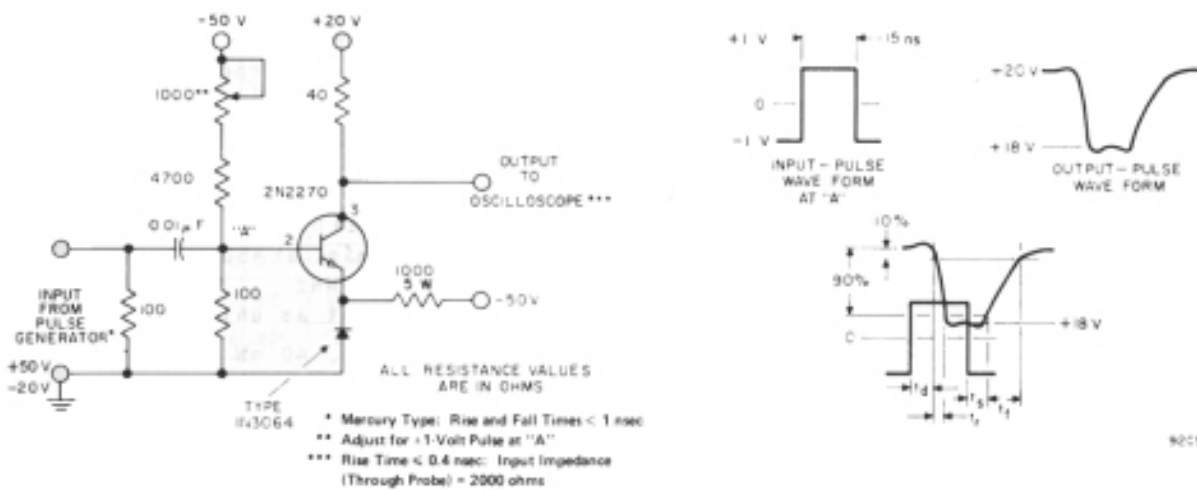

92CS-20295

Fig. 8—Test circuit for measurement of saturated switching time and associated waveforms.

TERMINAL CONNECTIONS

- Lead 1 — Emitter
- Lead 2 — Base
- Lead 3 — Collector, Case