

High Reliability CMOS Programmable Universal Asynchronous Receiver/Transmitter (UART)

March 1997

Features

- **Two Operating Modes**
 - **Mode 0 - Functionally Compatible with Industry Types Such as the TR1602A and CDP6402**
 - **Mode 1 - Interfaces Directly with CDP1800 Series Microprocessors without Additional Components**
- **Full or Half-Duplex Operation**
- **Parity, Framing, and Overrun Error Detection**
- **Fully Programmable with Externally Selectable Word Length (5-8 Bits), Parity Inhibit, Even/Odd Parity, and 1, 1-1/2, or 2 Stop Bits**

Ordering Information

PACK-AGE	TEMP. RANGE	5V/200K BAUD	10V/400K BAUD	PKG. NO.
SBDIP	-55°C to +125°C	CDP1854ACD3	CDP1854ACD3	D40.6

Description

The CDP1854A/3 and CDP1854AC/3 are high reliability silicon gate CMOS Universal Asynchronous Receiver/Transmitter (UART) circuits. They are designed to provide the necessary formatting and control for interfacing between serial and parallel data. For example, these UARTs can be used to interface between a peripheral or terminal with serial I/O ports and the 8-bit CDP1800-series microprocessor parallel data bus system. The CDP1854A/3 is capable of full duplex operation, i.e., simultaneous conversion of serial input data to parallel output data and parallel input data to serial output data.

The CDP1854A/3 UART can be programmed to operate in one of two modes by using the mode control input. When the mode input is high (MODE = 1), the CDP1854A/3 is directly compatible with the CDP1800 series microprocessor system without additional interface circuitry. When the mode input is low (MODE = 0), the device is functionally compatible with industry standard UARTs such as the TR1602A and CDP6402. It is also pin compatible with these types, except that pin 2 is used for the mode control input.

The CDP1854A/3 and the CDP1854AC/3 are functionally identical. The CDP1854A/3 has a recommended operating voltage range of 4V to 10.5V, and the CDP1854AC/3 has a recommended operating voltage range of 4V to 6.5V.

Pinouts

CDP1854A/3, CDP1854AC/3 (SBDIP) (MODE 0)
TOP VIEW

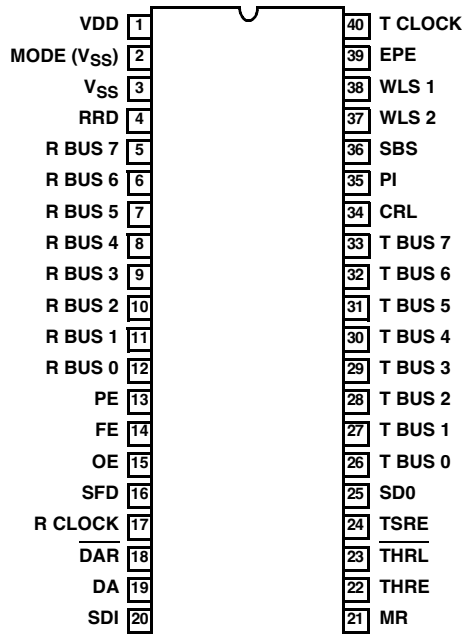

CDP1854A/3, CDP1854AC/3 (SBDIP) (MODE 1)
TOP VIEW

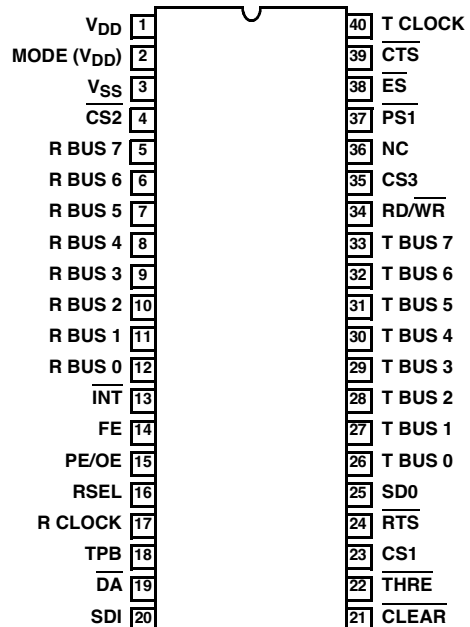

NC = NO CONNECT

CDP1854A/3, CDP1854AC/3

Absolute Maximum Ratings

DC Supply-Voltage Range, (V_{DD}) (All voltages referenced to V_{SS} terminal)	
CDP1854A/3	-0.5 to +11V
CDP1854AC/3	-0.5 to +7V
Input Voltage Range, All Inputs	-0.5 to $V_{DD} + 0.5V$
DC Input Current, Any One Input	$\pm 10mA$
Device Dissipation Per Output Transistor	
For T_A = Full Package-Temperature Range	100mW
Operating-Temperature Range (T_A)	
Package Type D	-55°C to +125°C

Thermal Information

Thermal Resistance (Typical, Note 1)	θ_{JA} (°C/W)	θ_{JC} (°C/W)
SBDIP Package	55	15
Maximum Junction Temperature	+150°C	
Maximum Storage Temperature Range (T_{STG})	-65°C to +150°C	
Maximum Lead Temperature (Soldering 10s)		
At Distance 1/16 \pm 1/32 inch (1.59 \pm 0.79mm)	+265°C	

CAUTION: Stresses above those listed in "Absolute Maximum Ratings" may cause permanent damage to the device. This is a stress only rating and operation of the device at these or any other conditions above those indicated in the operational sections of this specification is not implied.

NOTE:

- θ_{JA} is measured with the component mounted on an evaluation PC board in free air.

Static Electrical Specifications

PARAMETER		CONDITIONS			LIMITS				UNITS
		V_O (V)	V_{IN} (V)	V_{DD} (V)	-55°C, +25°C		+125°C		
					MIN	MAX	MIN	MAX	
Quiescent Device Current	I_{DD}	-	0, 5	5	-	500	-	1000	μA
		-	0, 10	10	-	500	-	1000	μA
Output Low Drive (Sink) Current	I_{OL}	0.4	0, 5	5	0.75	-	0.5	-	mA
		0.5	0, 10	10	1.80	-	1.2	-	mA
Output High Drive (Source) Current	I_{OH}	4.6	0, 5	5	-	-0.5	-	-0.35	mA
		9.5	0, 10	10	-	-1.0	-	-0.70	mA
Output Voltage Low-Level (Note 1)	V_{OL}	-	0, 5	5	-	0.1	-	0.2	V
		-	0, 10	10	-	0.1	-	0.2	V
Output Voltage High Level (Note 1)	V_{OH}	-	0, 5	5	4.9	-	4.9	-	V
		-	0, 10	10	9.9	-	9.8	-	V
Input Low Voltage	V_{IL}	0.5, 4.5	-	5	-	1.5	-	1.5	V
		0.5, 9.5	-	10	-	3	-	3	V
Input High Voltage	V_{IH}	0.5, 4.5	-	5	3.5	-	3.5	-	V
		0.5, 9.5	-	10	7	-	7	-	V
Input Leakage Current	I_{IN}	-	0, 5	5	-	± 1	-	± 5	μA
		-	0, 10	10	-	± 1	-	± 5	μA
Three-State Output Leakage Current	I_{OUT}	0, 5	0, 5	5	-	± 1	-	± 10	μA
		0, 10	0, 10	10	-	± 1	-	± 10	μA
Input Capacitance (Note 1)	C_{IN}	-	-	-	-	10	-	10	pF
Output Capacitance (Note 1)	C_{OUT}	-	-	-	-	15	-	15	pF

NOTE:

- Guaranteed but not tested.

Specifications CDP1854A/3, CDP1854AC/3

Operating Conditions At T_A = Full Package-Temperature Range. For maximum reliability, operating conditions should be selected so that operation is always within the following ranges:

PARAMETER	CONDITIONS V_{DD} (V)	LIMITS				UNITS
		-55°C, +25°C		+125°C		
		MIN	MAX	MIN	MAX	
DC Operating Voltage Range	-	4	10.5	4	6.5	V
Input Voltage Range	-	V_{SS}	V_{DD}	V_{SS}	V_{DD}	V
Baud Rate (Receive or Transmit)	5	-	250	-	215	K bits/s
	10	-	520	-	430	K bits/s

Dynamic Electrical Specifications $t_R, t_F = 15\text{ns}$, $V_{IH} = V_{DD}$, $V_{IL} = V_{SS}$, $C_L = 100\text{pF}$, (See Figure 1)

PARAMETER	V_{DD} (V)	LIMITS				UNITS	
		-55°C, +25°C		+125°C			
		MIN	MAX	MIN	MAX		
TRANSMITTER TIMING - MODE 1							
Clock Period	t_{CC}	5	240	-	280	ns	
		10	120	-	145	ns	
Pulse Width Clock Low Level	t_{CL}	5	105	-	125	ns	
		10	55	-	65	ns	
Clock High Level	t_{CH}	5	135	-	155	ns	
		10	65	-	80	ns	
TPB	t_{TT}	5	125	-	165	ns	
		10	70	-	80	ns	
Propagation Delay Time Clock to Data Start Bit	t_{CD}	5	-	425	-	485	ns
		10	-	205	-	235	ns
TPB to $\overline{\text{THRE}}$	t_{TTH}	5	-	315	-	380	ns
		10	-	155	-	185	ns
Clock to $\overline{\text{THRE}}$	t_{CTH}	5	-	335	-	390	ns
		10	-	160	-	190	ns

CDP1854A/3, CDP1854AC/3

Dynamic Electrical Specifications $t_R, t_F = 15\text{ns}$, $V_{IH} = V_{DD}$, $V_{IL} = V_{SS}$, $C_L = 100\text{pF}$, (See Figure 2)

PARAMETER	V_{DD} (V)	LIMITS				UNITS	
		-55°C, +25°C		+125°C			
		MIN	MAX	MIN	MAX		
RECEIVER TIMING - MODE 1							
Clock Period	t_{CC}	5	240	-	280	-	ns
		10	120	-	145	-	ns
Pulse Width Clock Low Level	t_{CL}	5	105	-	125	-	ns
		10	55	-	65	-	ns
Clock High Level	t_{CH}	5	135	-	155	-	ns
		10	65	-	80	-	ns
TPB	t_{TT}	5	125	-	165	-	ns
		10	70	-	80	-	ns
Setup Time Data Start Bit to Clock	t_{DC}	5	105	-	120	-	ns
		10	65	-	70	-	ns
Propagation Delay Time TPB to $\overline{\text{DATA AVAILABLE}}$	t_{TDA}	5	-	295	-	340	ns
		10	-	150	-	170	ns
Clock to $\overline{\text{DATA AVAILABLE}}$	t_{CDA}	5	-	305	-	355	ns
		10	-	150	-	170	ns
Clock to Overrun Error	t_{COE}	5	-	305	-	330	ns
		10	-	150	-	175	ns
Clock to Parity Error	t_{CPE}	5	-	305	-	330	ns
		10	-	150	-	175	ns
Clock to Framing Error	t_{CFE}	5	-	280	-	330	ns
		10	-	145	-	165	ns

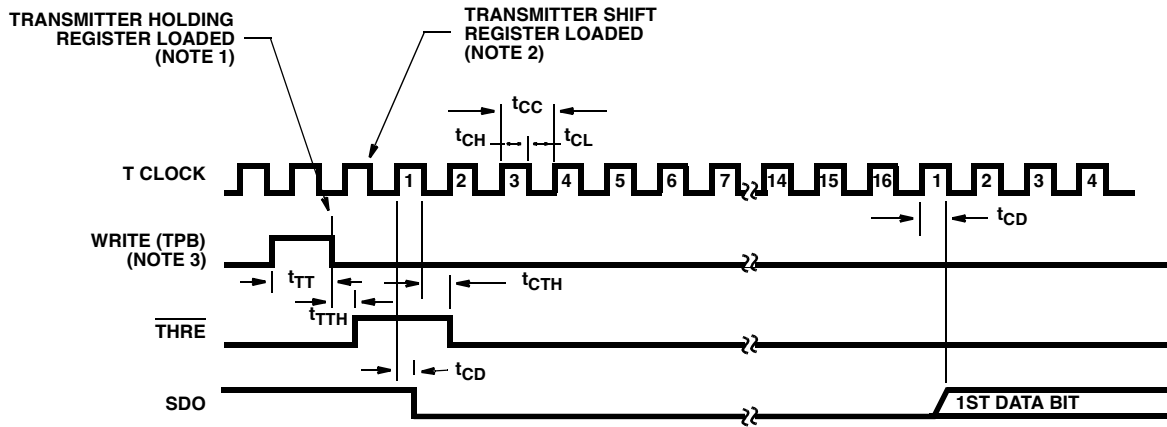

NOTES:

1. The holding register is loaded on the trailing edge of TPB.
2. The transmitter shift register, if empty, is loaded on the first high-to-low transition of the clock which occurs at least $1/2$ clock period + t_{TC} after the trailing edge of TPB and transmission of a start bit occurs $1/2$ clock period + t_{CD} later.
3. Write is the overlap of TPB, CS1, and CS3 = 1 and $\overline{CS3}$, $\overline{RD/\overline{WR}}$ = 0

FIGURE 1. TRANSMITTER TIMING DIAGRAM - MODE 1

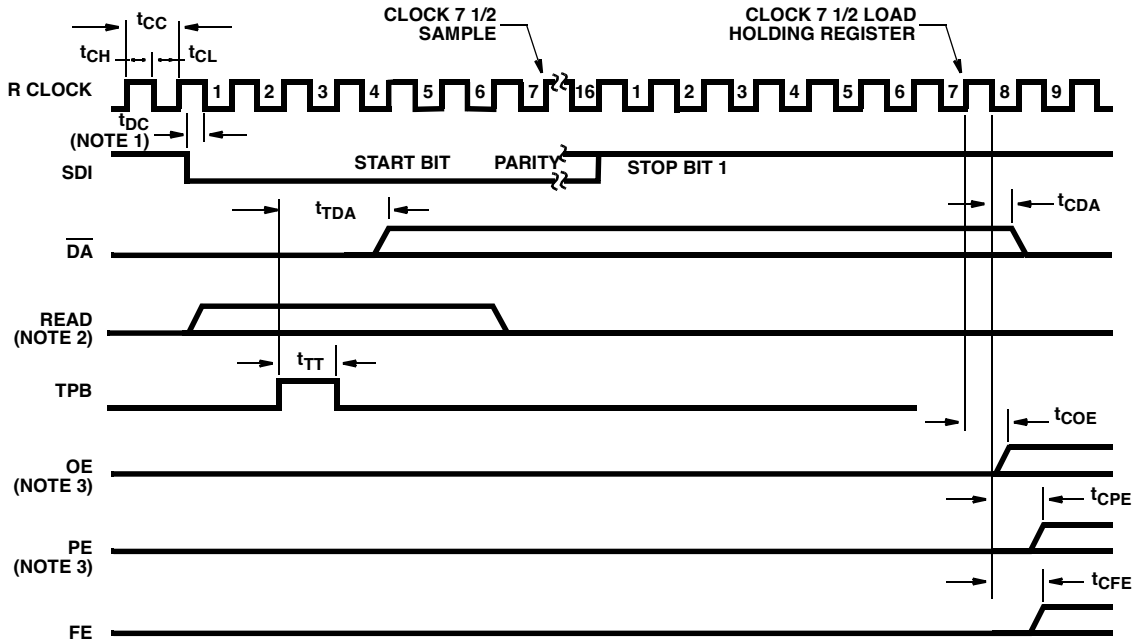

NOTES:

1. If a start bit occurs at a time less than t_{DC} before a high-to-low transition of the clock, the start bit may not be recognized until the next high-to-low transition of the clock. The start bit may be completely asynchronous with the clock.
2. Read is the overlap of CS1, CS3, $\overline{RD/\overline{WR}}$ = 1 and $\overline{CS2}$ = 0. If a pending DA has not been cleared by a read of the receiver holding register by the time a new word is loaded into the receiver holding register, the OE signal will come true.
3. OE and PE share terminal 15 and are also available as two separate bits in the status register.

FIGURE 2. MODE 1 RECEIVER TIMING DIAGRAM

CDP1854A/3, CDP1854AC/3

Dynamic Electrical Specifications $t_R, t_F = 15\text{ns}$, $V_{IH} = V_{DD}$, $V_{IL} = V_{SS}$, $C_L = 100\text{pF}$, (See Figure 3)

PARAMETER	V_{DD} (V)	LIMITS				UNITS	
		-55°C, +25°C		+125°C			
		MIN	MAX	MIN	MAX		
CPU INTERFACE - WRITE TIMING - MODE 1							
Pulse Width TPB	t_{TT}	5	125	-	165	-	ns
		10	70	-	80	-	ns
Setup Time RSEL to Write	t_{RSW}	5	20	-	10	-	ns
		10	25	-	25	-	ns
Data to Write	t_{DW}	5	65	-	75	-	ns
		10	45	-	50	-	ns
Hold Time RSEL after Write	t_{WRS}	5	-10	-	-20	-	ns
		10	5	-	5	-	ns
Data after Write	t_{WD}	5	95	-	105	-	ns
		10	55	-	55	-	ns

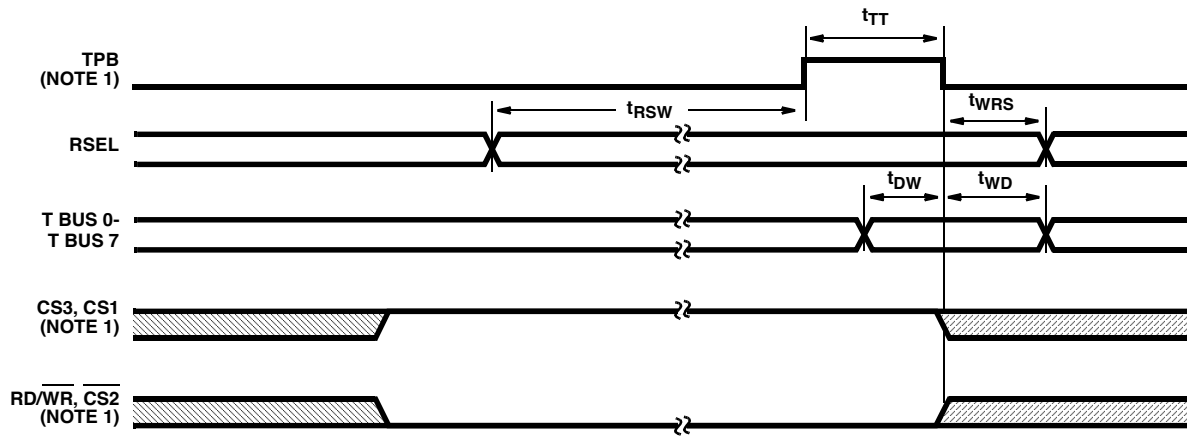

NOTE:

1. Write is the overlap of TPB, CS1, CS3 = 1 and $\overline{CS2}$, $\overline{RD/WR}$ = 0.

FIGURE 3. MODE 1 CPU INTERFACE (WRITE) TIMING DIAGRAM

CDP1854A/3, CDP1854AC/3

Dynamic Electrical Specifications $t_R, t_F = 15\text{ns}$, $V_{IH} = V_{DD}$, $V_{IL} = V_{SS}$, $C_L = 100\text{pF}$, (See Figure 4)

PARAMETER	V_{DD} (V)	LIMITS				UNITS	
		-55°C, +25°C		+125°C			
		MIN	MAX	MIN	MAX		
CPU INTERFACE - READ TIMING - MODE 1							
Pulse Width TPB	t_{TT}	5	125	-	165	-	ns
		10	70	-	80	-	ns
Setup Time RSEL to TPB	t_{RST}	5	15	-	0	-	ns
		10	20	-	10	-	ns
Hold Time RSEL after TPB	t_{TRS}	5	-10	-	-25	-	ns
		10	5	-	0	-	ns
Propagation Delay Time Read to Data Valid Time	t_{RDV}	5	-	360	-	420	ns
		10	-	165	-	195	ns
RESEL to Data Valid Time	t_{RSDV}	5	-	250	-	295	ns
		10	-	125	-	145	ns

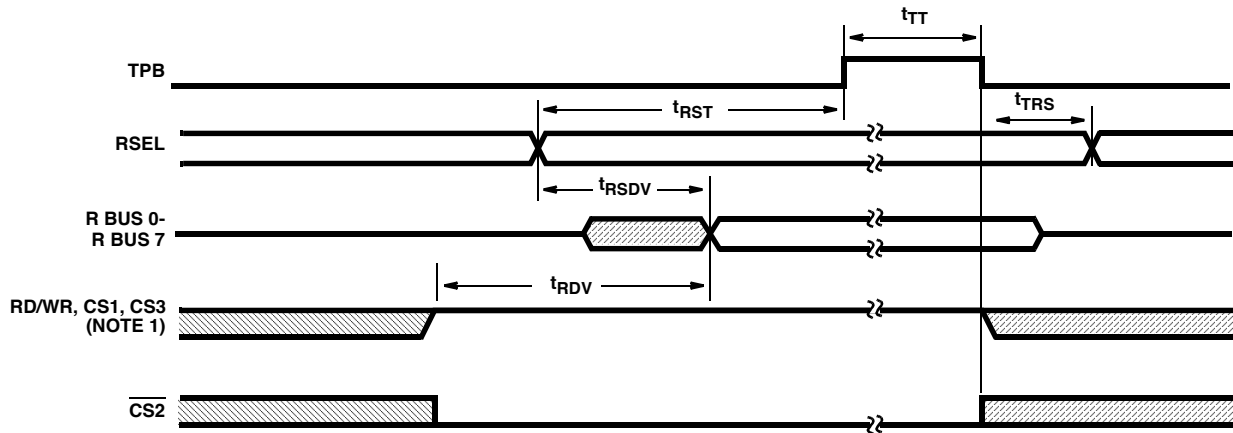

NOTE:

1. Read is the overlap of CS1, CS3, $\overline{RD/WR} = 1$ and $\overline{CS2} = 0$.

FIGURE 4. MODE 1 CPU INTERFACE (READ) TIMING DIAGRAM

CDP1854A/3, CDP1854AC/3

Dynamic Electrical Specifications $t_R, t_F = 15\text{ns}$, $V_{IH} = V_{DD}$, $V_{IL} = V_{SS}$, $C_L = 100\text{pF}$, (See Figure 5)

PARAMETER	V_{DD} (V)	LIMITS				UNITS	
		-55°C, +25°C		+125°C			
		MIN	MAX	MIN	MAX		
INTERFACE TIMING - MODE 0							
Pulse Width CRL	t_{CRL}	5	105	-	125	-	ns
		10	55	-	65	-	ns
MR	t_{MR}	5	340	-	385	-	ns
		10	160	-	175	-	ns
Setup Time Control Word to CRL	t_{CWC}	5	80	-	85	-	ns
		10	40	-	60	-	ns
Hold Time Control Word after CRL	t_{CCW}	5	65	-	65	-	ns
		10	45	-	45	-	ns
Propagation Delay Time SFD High to SOD	t_{SFDH}	5	-	175	-	195	ns
		10	-	105	-	115	ns
SFD Low to SOD	t_{SFDL}	5	165	-	195	-	ns
		10	90	-	105	-	ns
RRD High to Receiver Register High Impedance	t_{RRDH}	5	-	185	-	205	ns
		10	-	110	-	130	ns
RRD Low to Receiver Register Active	t_{RRDL}	5	165	-	195	-	ns
		10	90	-	105	-	ns

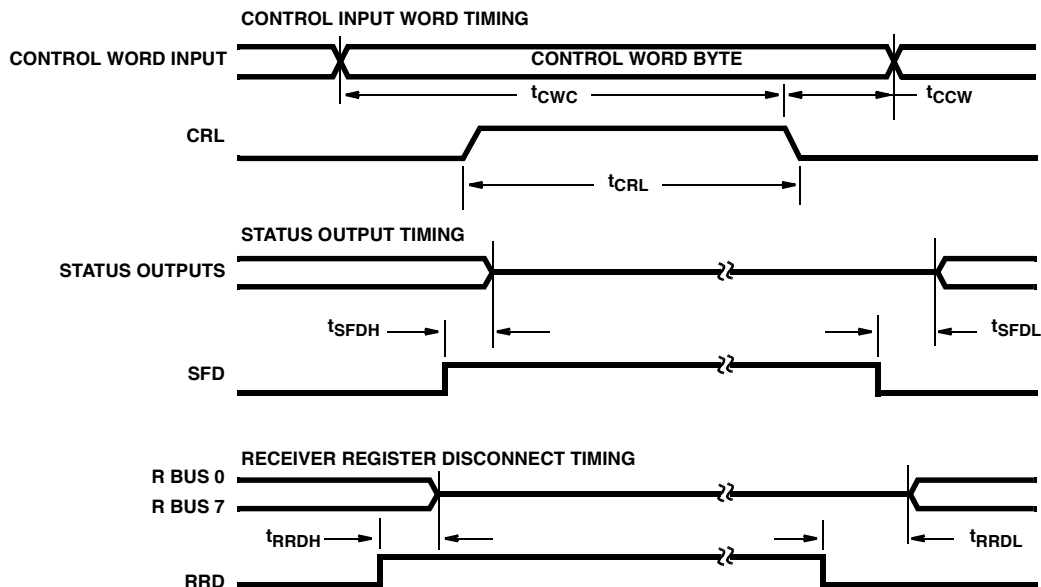

FIGURE 5. MODE 0 INTERFACE TIMING DIAGRAM

CDP1854A/3, CDP1854AC/3

Dynamic Electrical Specifications $t_R, t_F = 15\text{ns}$, $V_{IH} = V_{DD}$, $V_{IL} = V_{SS}$, $C_L = 100\text{pF}$, (See Figure 6)

PARAMETER	V_{DD} (V)	LIMITS				UNITS	
		-55°C, +25°C		+125°C			
		MIN	MAX	MIN	MAX		
TRANSMITTER TIMING - MODE 0							
Clock Period	t_{CC}	5	240	-	280	-	ns
		10	120	-	145	-	ns
Pulse Width Clock Low Level	t_{CL}	5	105	-	125	-	ns
		10	55	-	65	-	ns
Clock High Level	t_{CH}	5	135	-	155	-	ns
		10	65	-	80	-	ns
$\overline{\text{THRL}}$	t_{THTH}	5	140	-	165	-	ns
		10	80	-	85	-	ns
Setup Time $\overline{\text{THRL}}$ to Clock	t_{THC}	5	205	-	235	-	ns
		10	120	-	140	-	ns
Data to $\overline{\text{THRL}}$	t_{DT}	5	25	-	30	-	ns
		10	20	-	25	-	ns
Hold Time Data after $\overline{\text{THRL}}$	t_{TD}	5	60	-	95	-	ns
		10	45	-	75	-	ns
Propagation Delay Time Clock to Data Start Bit	t_{CD}	5	-	435	-	505	ns
		10	-	205	-	235	ns
Clock to THRE	t_{CT}	5	-	345	-	420	ns
		10	-	175	-	200	ns
$\overline{\text{THRL}}$ to THRE	t_{TTHR}	5	-	275	-	325	ns
		10	-	145	-	165	ns
Clock to TSRE	t_{TTS}	5	-	345	-	405	ns
		10	-	165	-	190	ns

CDP1854A/3, CDP1854AC/3

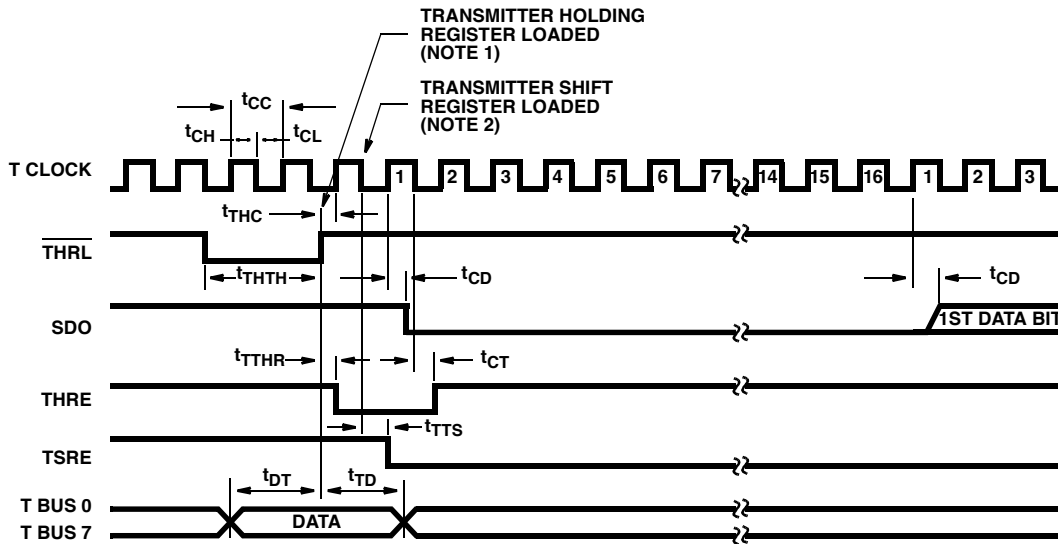

NOTES:

1. The holding register is loaded on the trailing edge of $\overline{\text{THRL}}$.
2. The transmitter shift register, if empty, is loaded on the first high-to-low transition of the clock which occurs at least $1/2$ clock period + t_{THC} after the trailing edge of $\overline{\text{THRL}}$ and transmission of a start bit occurs $1/2$ clock period + t_{CD} later.

FIGURE 6. MODE 0 TRANSMITTER TIMING DIAGRAM

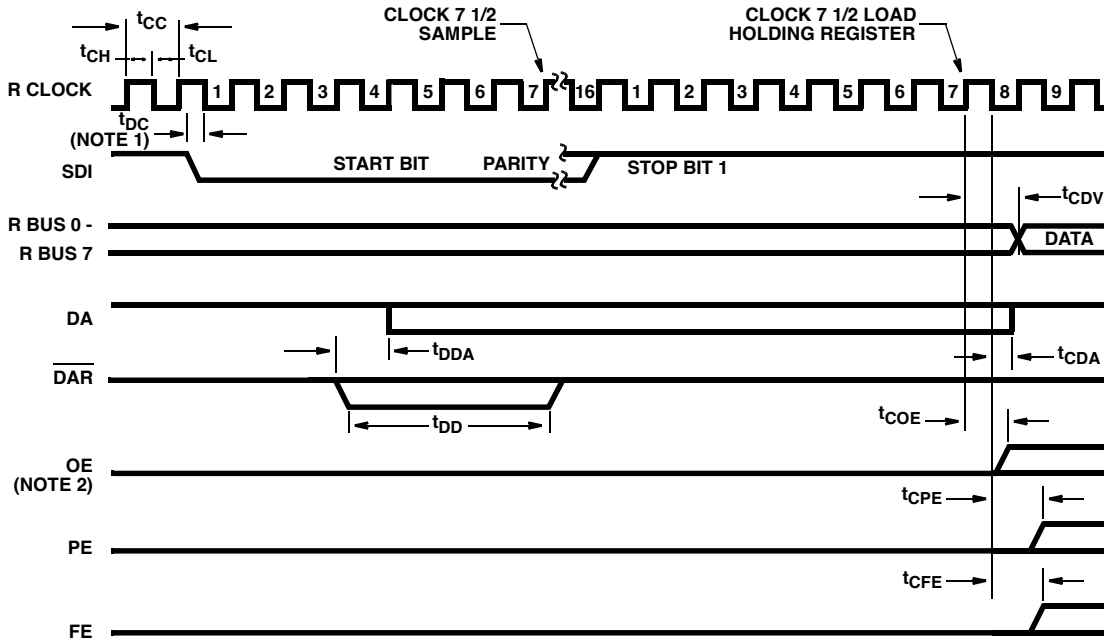

NOTES:

1. If a start bit occurs at a time less than t_{DC} before a high-to-low transition of the clock, the start bit may not be recognized until the next high-to-low transition of the clock. The start bit may be completely asynchronous with the clock.
2. If a pending DA has not been cleared by a read of the receiver holding register by the time a new word is loaded into the receiver holding register, the OE signal will come true.

FIGURE 7. MODE 0 RECEIVER TIMING DIAGRAM

CDP1854A/3, CDP1854AC/3

Dynamic Electrical Specifications $t_R, t_F = 15\text{ns}$, $V_{IH} = V_{DD}$, $V_{IL} = V_{SS}$, $C_L = 100\text{pF}$, (See Figure 7)

PARAMETER	V_{DD} (V)	LIMITS				UNITS	
		-55°C, +25°C		+125°C			
		MIN	MAX	MIN	MAX		
RECEIVER TIMING - MODE 0							
Clock Period	t_{CC}	5	240	-	280	-	ns
		10	120	-	145	-	ns
Pulse Width Clock Low Level	t_{CL}	5	105	-	125	-	ns
		10	55	-	65	-	ns
Clock High Level	t_{CH}	5	135	-	155	-	ns
		10	65	-	80	-	ns
$\overline{\text{DATA AVAILABLE RESET}}$	t_{DD}	5	75	-	90	-	ns
		10	45	-	50	-	ns
Setup Time Data Start Bit to Clock	t_{DC}	5	105	-	130	-	ns
		10	65	-	85	-	ns
Propagation Delay Time $\overline{\text{DATA AVAILABLE RESET}}$ to Data Available	t_{DDA}	5	-	240	-	280	ns
		10	-	130	-	145	ns
Clock to Data Valid	t_{CDV}	5	-	360	-	420	ns
		10	-	175	-	195	ns
Clock to Data Available	t_{CDA}	5	-	320	-	375	ns
		10	-	155	-	180	ns
Clock to Overrun Error	t_{COE}	5	-	365	-	415	ns
		10	-	170	-	190	ns
Clock to Parity Error	t_{CPE}	5	-	275	-	320	ns
		10	-	135	-	155	ns
Clock to Framing Error	t_{CFE}	5	-	270	-	320	ns
		10	-	135	-	165	ns

CDP1854A/3, CDP1854AC/3

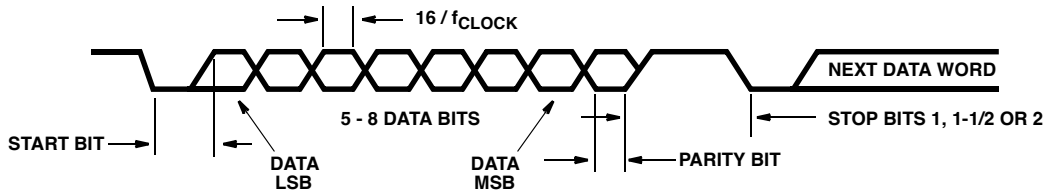
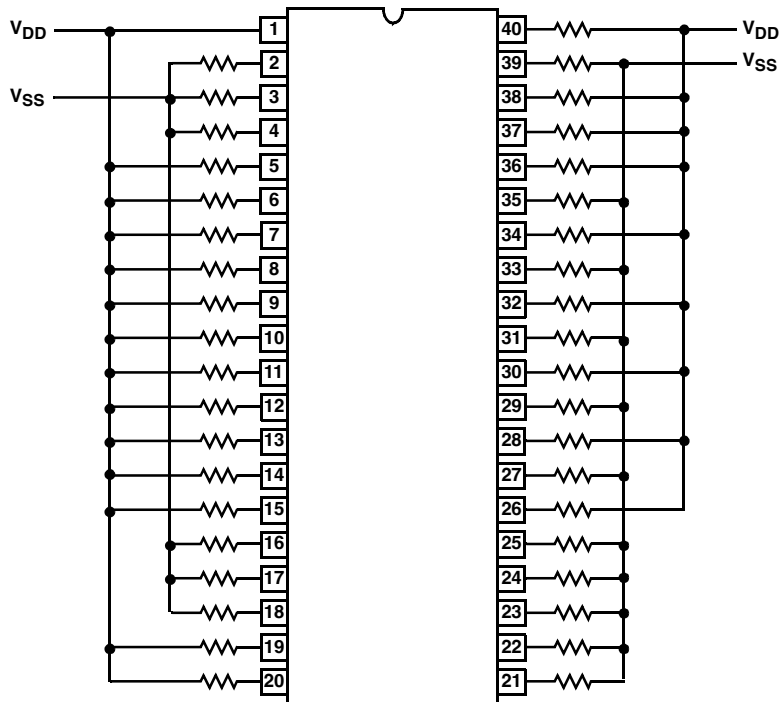

FIGURE 8. SERIAL DATA WORD FORMAT

Burn-In Circuit



ALL RESISTORS ARE 47kΩ ±20%

TYPE	V _{DD}	TEMPERATURE	TIME
CDP1854A/3	11	+125°C	160 hrs.
CDP1854AC/3	7	+125°C	160 hrs.

FIGURE 9. BIAS/STATIC BURN-IN CIRCUIT

All Intersil U.S. products are manufactured, assembled and tested utilizing ISO9000 quality systems.
Intersil Corporation's quality certifications can be viewed at www.intersil.com/design/quality

Intersil products are sold by description only. Intersil Corporation reserves the right to make changes in circuit design, software and/or specifications at any time without notice. Accordingly, the reader is cautioned to verify that data sheets are current before placing orders. Information furnished by Intersil is believed to be accurate and reliable. However, no responsibility is assumed by Intersil or its subsidiaries for its use; nor for any infringements of patents or other rights of third parties which may result from its use. No license is granted by implication or otherwise under any patent or patent rights of Intersil or its subsidiaries.

For information regarding Intersil Corporation and its products, see www.intersil.com