

AFSAG 1236

Register No. 3275

CONFIDENTIAL
SECURITY INFORMATION

INTERIM OPERATING INSTRUCTIONS
FOR
POLLUX CRYPTOSYSTEMS—JOINT

This document consists of cover and 45 numbered
pages, 1 to 45 inclusive

Verify presence of each page upon receipt

DEPARTMENT OF DEFENSE
ARMED FORCES SECURITY AGENCY
WASHINGTON 25, D. C.

**CSEC information declassified and
approved for release on 28 April 2011,
CSEC ATIP Case #A-2010-00015**

**NSA information declassified and
approved for release on 21 April
2011, FOIA Case # 64246**

JANUARY 1953

CONFIDENTIAL

1

ORIGINAL

DOCID: 3842901

AFSAG 1236

~~CONFIDENTIAL~~

DEPARTMENT OF DEFENSE
NATIONAL SECURITY AGENCY
WASHINGTON 25, D. C.

26 January 1958

INTERIM OPERATING INSTRUCTIONS FOR POLLUX CRYPTOSYSTEMS—JOINT

LETTER OF PROMULGATION

1. AFSAG 1236 is a CONFIDENTIAL Registered Publication and will be handled, stored, and accounted for in accordance with regulations of each Service pertaining to classified cryptomaterial.

2. AFSAG 1236 will become effective upon receipt. Instructions for the eventual disposal of this document will be issued at an appropriate time by the Director, National Security Agency, through normal Service channels.

3. Changes to this publication will be promulgated by means of a registered change, letter, memorandum, or message and are to be entered upon receipt. The individual entering the changes shall so indicate on the Record of Corrections page included herein as page 3.

4. This publication is distributed to authorized holders of AFSAM 7 and associated publications.

5. THIS DOCUMENT CONTAINS INFORMATION AFFECTING THE NATIONAL DEFENSE OF THE UNITED STATES WITHIN THE MEANING OF THE ESPIONAGE LAWS, TITLE 18, U. S. C., SECTIONS 793, 794 AND TITLE 50, U. S. C., SECTIONS 46, 46a AND 46b. ITS TRANSMISSION OR THE REVELATION OF ITS CONTENTS IN ANY MANNER TO AN UNAUTHORIZED PERSON IS PROHIBITED BY LAW.

6. EXTRACTS FROM THIS PUBLICATION MAY BE MADE IF NECESSARY. SUCH EXTRACTS, IF MADE, WILL BE CLASSIFIED CONFIDENTIAL AND ACCOUNTED FOR LOCALLY UNTIL DULY DESTROYED.



RALPH J. CANINE
Major General, US Army
Director, National Security Agency

~~CONFIDENTIAL~~

ORIGINAL

~~CONFIDENTIAL~~

AFSAG 1236

TABLE OF CONTENTS

CHAPTER 1
DESCRIPTION

| Section | Paragraphs | Pages |
|----------------------------------|------------|-------|
| 1000 GENERAL | | |
| POLLUX Operation..... | 1001 | 7 |
| Category of Cryptosystems..... | 1002 | 7 |
| Authorization for Use..... | 1003 | 7 |
| Maintenance..... | 1004 | 7 |
| Comments or Recommendations..... | 1005 | 7 |
| 1100 AFSAM 7 | | |
| General..... | 1101 | 9 |
| Keyboard..... | 1102 | 9 |
| Function Controller..... | 1103 | 9 |
| Rotor Stepping Unit..... | 1104 | 9 |
| Cipher Unit..... | 1105 | 9 |
| Power Requirements..... | 1106 | 9 |
| 1200 KEYING MATERIALS | | |
| Rotors..... | 1201 | 11 |
| Key Lists..... | 1202 | 11 |

CHAPTER 2
OPERATION

| | | |
|--|------------|-------|
| 2000 KEYING INSTRUCTIONS | | |
| Rotor Assembly and Arrangement..... | 2001 | 13 |
| 36-45 Check..... | 2002 | 13-14 |
| System Indicator and Message Classification..... | 2003 | 14 |
| Message Indicator..... | 2004 | 14 |
| Message Rotor Alignment..... | 2006 | 14 |
| 2100 ENCIPHERING AND DECIPHERING | | |
| Application of General Cryptoprocedures..... | 2101 | 15 |
| Sequence of Operations in Encipherment..... | 2102 | 16 |
| Sequence of Operations in Decipherment..... | 2103 | 15 |
| 2200 AIDS FOR DECIPHERING GARBLED MESSAGES | | |
| General..... | 2201 | 16 |
| When No Plain Text Appears..... | 2202 | 16 |
| When Some Plain Text Appears..... | 2203 | 16-17 |
| Special AFSAM 7 Garbles..... | 2204 | 17 |

CHAPTER 3
PHYSICAL SECURITY

| | | |
|---|------------|----|
| 3000 GENERAL | | |
| Custodian..... | 3001 | 19 |
| Accounting..... | 3002 | 19 |
| Use and Transport in Aircraft..... | 3003 | 19 |
| Other Physical Security Considerations..... | 3004 | 19 |
| Clearances..... | 3005 | 19 |
| Emergency Procedures..... | 3006 | 19 |

~~CONFIDENTIAL~~

ORIGINAL

DOCID: 3842901

~~CONFIDENTIAL~~

AFSAG 1236

CHAPTER 4

VIOLATIONS OF PHYSICAL SECURITY AND CRYPTOSECURITY

| Section | Paragraphs | Pages |
|--|------------|-------|
| 4000 REPORTING VIOLATIONS | | |
| General..... | 4001 | 21 |
| Action by Reporting Stations..... | 4002 | 21 |
| Action by Higher Headquarters on Receipt of Message Reports..... | 4003 | 21 |
| 4100 SPECIFIC VIOLATIONS | | |
| General..... | 4101 | 32 |

CHAPTER 5

MAINTENANCE INSTRUCTIONS FOR INTERMEDIATE REPAIR FACILITIES

| | | |
|--|------|-------|
| 5000 PREPARATION FOR USE | | |
| General..... | 5001 | 23 |
| Storage..... | 5002 | 23 |
| Unpacking the Equipment..... | 5003 | 23 |
| Initial Inspection..... | 5004 | 23 |
| Installation Procedure..... | 5005 | 23-25 |
| Test Procedure..... | 5006 | 25-26 |
| Operation of AFSAM 7 in Office Case..... | 5007 | 26 |
| Errors in Reproduction..... | 5008 | 27 |
| <i>From Reporting Station 7 and Repaired</i> | 5009 | 27 |
| 5100 COMPONENT ASSEMBLIES | | |
| Cipher Machine..... | 5101 | 28 |
| Base Assembly..... | 5102 | 28 |
| Keyboard Assembly..... | 5103 | 28 |
| Contact Panel Assembly..... | 5104 | 28 |
| Printer Assembly..... | 5105 | 28 |
| Stepping Unit Assembly..... | 5106 | 28 |
| Cipher Unit Assembly..... | 5107 | 28 |
| AC Power Converter Assembly..... | 5108 | 29 |
| Carrying Case Assembly..... | 5109 | 29 |
| Accessories and Case Assembly..... | 5110 | 29 |
| Office Case Assembly..... | 5111 | 29 |
| 5200 SUBSTITUTION OF COMPONENT ASSEMBLIES | | |
| General..... | 5201 | 30 |
| Keyboard Assembly..... | 5202 | 30 |
| Cipher Unit Assembly..... | 5203 | 30 |
| Stepping Unit Assembly..... | 5204 | 31 |
| Printer Assembly..... | 5205 | 31 |
| Contact Panel Assembly..... | 5206 | 31-32 |
| AC Power Converter Assembly..... | 5207 | 32 |
| 5300 TROUBLE SHOOTING | | |
| Simplified Trouble-Shooting Chart..... | 5301 | 33-36 |
| 5400 CLEANING | | |
| General Instructions..... | 5401 | 37 |
| Flat Head and Pressure Contacts..... | 5402 | 37 |
| Cipher Unit Assembly..... | 5403 | 37 |
| Stepping Unit Assembly..... | 5404 | 37 |
| Printer Assembly..... | 5405 | 37-38 |
| Keyboard Assembly..... | 5406 | 38 |
| Contact Panel Assembly..... | 5407 | 38 |
| 5500 REPLACEMENT ASSEMBLIES AND TOOLS | | |
| Replacement Assemblies..... | 5501 | 39 |
| Recommended Tools..... | 5502 | 39 |

~~CONFIDENTIAL~~

ORIGINAL

~~CONFIDENTIAL~~

AFSAG 1236

CHAPTER 1

DESCRIPTION

1000—GENERAL

1001. POLLUX Operation.—The designator POLLUX applies to the general cryptosystem produced by the cipher machine AFSAM 7.

1002. Category of Cryptosystems.—Cryptosystems employing AFSAM 7 are Category A as explained in Section 2100, AFSAG 1210A.

1003. Authorization for Use.—The AFSAM 7 is authorized for the encipherment of messages of all classifications.

1004. Maintenance. Chapter 5 contains instructions to be followed in the maintenance and repair of the cipher machine by intermediate repair facilities.

1005. Comments or Recommendations.—It is requested that any comments or recommendations concerning the instructions contained herein be submitted to the Director, National Security Agency, Attn: NSA-04, through normal Service channels. Such comments or recommendations should be specific as to page or paragraph number and subject matter. It is particularly important that any instructions which are not clear, are too brief, or are apparently lacking, be reported without delay in order that any necessary corrections may be promulgated by change or superseding editions.

~~CONFIDENTIAL~~

DIVULGUÉ EN VERTU DE LA LAI RENSEIGNEMENTS NON CLASSIFIÉS

DOCID: 3842901

~~CONFIDENTIAL~~

AFSAG 1236

1100—AFSAM 7

1101. General.—The AFSAM 7 is a keyboard-operated tape-printing cipher machine. Each machine is designed on a unit assembly basis. The rotor stepping unit (AFSAM 107) and the cipher unit (AFSAM 207) are CONFIDENTIAL and registered. The base (AFSAM 7) is RESTRICTED and registered. (See pl. 1, pp. 10.)

1102. Keyboard.—The *keyboard* resembles a typewriter keyboard and can be operated at a maximum speed of 60 words per minute. The keyboard includes 26 alphabet keys (the top row of which also includes the numerals 1 to 0), a "RPT" (Repeat) key, a "FIG" (Figures) key, a "LET" (Letters) key, and a space bar. When the "RPT" key is depressed in conjunction with any operative key, the machine will operate continuously until the "RPT" key is released. The "FIG" key causes a figures shift in the printer so that the keys in the top row will print figures. The "LET" key causes the printer to unshift producing lower case (letters) versions.

1103. Function Controller.—The positions of the function controller and their effect on the operation of the machine are as follows:

- a. "O" Position (*Off*)—The power line is open and no current is supplied to the machine.
- b. "P" Position (*Plain text*).
 - (1) All keys and the space bar are operative; the machine will print text exactly as typed. The rotors remain motionless during typing.
 - (2) With the function controller in the "P" position, rotors may be aligned by depressing the individual rotor-set keys which are located beneath the rotor apertures of the cipher unit.
- c. "E" Position (*Encipher*).—All keys and the space bar are operative. The machine enciphers any character struck and prints the result in five-letter groups. The rotor maze advances when the "FIG" or "LET" key is depressed.
- d. "D" Position (*Decipher*).—All keys are operative. The space bar is inoperative. The machine decipheres the letters struck on the keyboard and prints the resulting plain text. The rotor maze does not step when the "FIG" or "LET" key is depressed.

Note: The numbers 1 through 0 appear on the top row of alphabet keys. When the "FIG" key is struck during decipherment, enciphered versions of the letters of the top row will decipher as the numerical equivalents appearing on the corresponding keys. For example, "E" and "3" appear on the same key; if the "FIG" key is struck, enciphered "E" will decipher as "3."

1104. Rotor Stepping Unit.—The rotor stepping unit, AFSAM 107, is mounted on the base of the machine. It may be removed by loosening the two captive thumb screws and pulling the unit toward the operator and up.

1105. Cipher Unit.—The cipher unit, AFSAM 207, is mounted in the AFSAM 107. It has a shaft on which eight rotor assemblies may be mounted. The cipher unit may be removed by depressing the cipher unit latches on either side of the unit.

1106. Power Requirements.—The AFSAM 7 is operated from a 21-31 volt d. c. power supply. A power converter may be obtained for 100-125 or 200-250 volt (50-60 cycle) alternating current.

~~CONFIDENTIAL~~

9

ORIGINAL

DOCID: 3842901

~~CONFIDENTIAL~~

AFSAG 1236

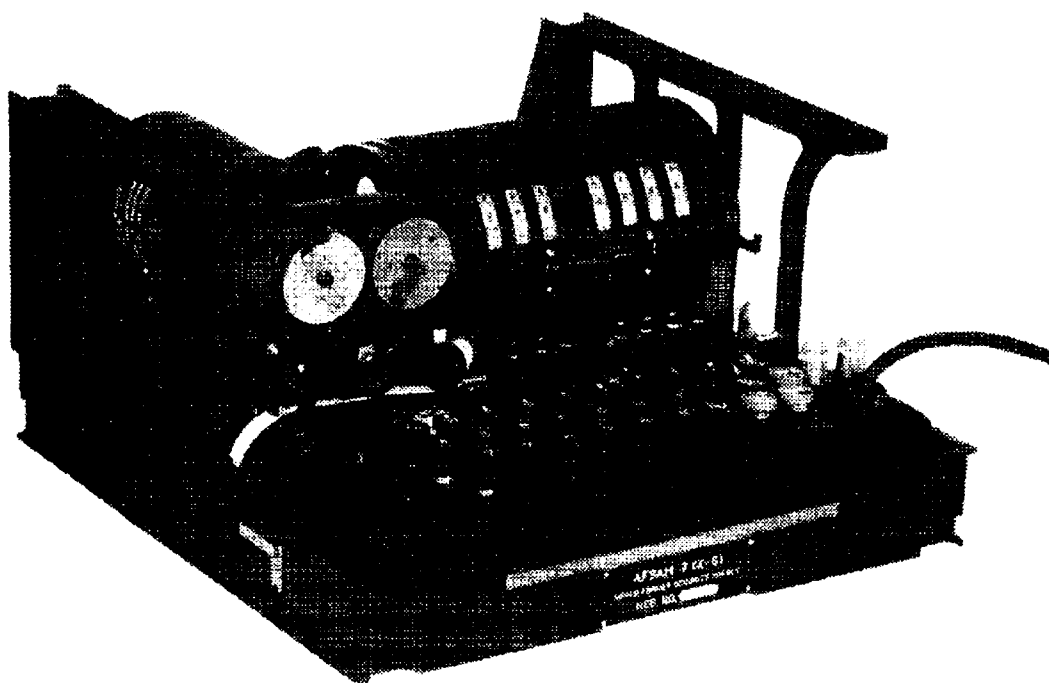

Plate 1

~~CONFIDENTIAL~~

ORIGINAL

DOCID: 3842901

CONFIDENTIAL

AFSAG 1236

1200—KEYING MATERIALS

1201. Rotors.

- a. Sets of eight rotor assemblies, each set consisting of eight cores, eight retaining rings, seven alphabet rings (plus one extra ring), seven notch rings, and one wide ring, are issued for use with the AFSAM 7. Rotor assemblies are CONFIDENTIAL and registered. Each set of rotor assemblies is identified by a title and a number. Each of seven of the rotor assemblies consists of a core identified by a letter-number pattern, a correspondingly numbered notch ring, an alphabet ring, and a lock ring; the eighth assembly consists of a core, a wide ring, and a lock ring. Each complete assembly is accountable by its core number.
- b. The numbers 1 to 26 appear on the sides of the alphabet rings and the wide ring. Each of these rings is set with the number designated by the key list aligned to the bench mark of a core. Each notch ring is set independently to a letter on its associated alphabet ring according to the key list. The rotor assemblies are *not* reversible. The wide ring assembly **MUST ALWAYS BE PLACED IN THE FOURTH POSITION IN THE CIPHER UNIT.**

1202. Key Lists.

- a. Certain key lists used with the AFSAM 7 bear the designator POLLUX. Each key list is SECRET and registered* and contains the following material for each date:
 - (1) A list of the cores to be placed in each of the eight positions in the cipher unit.
 - (2) The setting of the alphabet ring to be used with each core.
 - (3) The setting of the wide ring on the core in the fourth position.
 - (4) The notch ring to be used with each core (listed in conjunction with the letter of the alphabet ring to which the notch ring bench mark is to be set).
 - (5) The rotor assemblies are listed from left to right in the order in which they are to be inserted in the cipher unit.
 - (6) A system indicator.

- b. The arrangement of the keying data in a POLLUX key list is illustrated below:

| | 1 | | | 2 | | | 3 | | | 4 | | 5 | | |
|---|---|-----------|-----|---|-----------|------|---|-----------|-----|---|------|---|-----------|--|
| D | C | Notch | | C | Notch | | C | Notch | | C | | C | Notch | |
| A | O | Alph Ring | | O | Alph Ring | | O | Alph Ring | | O | WIDE | O | Alph Ring | |
| T | R | Ring & | | R | Ring & | | R | Ring & | | R | RING | R | Ring & | |
| E | E | Set | Set | E | Set | Set | E | Set | Set | E | Set | E | Set | |
| 1 | 7 | 13 | 6-G | 8 | 7 | 3-M+ | 5 | 2 | 2-F | 2 | 23 | 1 | 11 5-J+ | |

| 6 | | | 7 | | | 8 | | | System Indicator | |
|---|-----------|-----|---|-----------|-----|---|-----------|-----|------------------|--|
| C | Notch | | C | Notch | | C | Notch | | | |
| O | Alph Ring | | O | Alph Ring | | O | Alph Ring | | 3B-45 LTR | |
| R | Ring & | | R | Ring & | | R | Ring & | | CK GPS | |
| E | Set | Set | E | Set | Set | E | Set | Set | QXPDI/MXRES | |
| 6 | 35 | 7-P | 3 | 5 | 4-A | 4 | 18 | 1-R | 4-10-50 | |

Note: Blank spaces on alphabet rings are indicated in key lists by the letters which precede them in the alphabet printed in conjunction with a plus (+) sign. Thus, "J+" indicates the space between the letter J and K, "M+" indicates the space between M and N, etc. There are 10 such spaces on each alphabet ring.

*Daily SOI extracts of NSA-produced SECRET and registered master copies are CONFIDENTIAL and non-registered.

CONFIDENTIAL

DOCID: 3842901

f. Additional Information on Rotor Assembly.

- (1) To permit disassembly; remove the retaining ring by grasping and squeezing both of the retaining ring projections and simultaneously lifting upward.
- (2) To replace the retaining ring after properly aligning the alphabet and notch rings; hold the assembled core flat side down with one hand, grasp and squeeze the retaining ring projections with the thumb and index finger of the other hand and insert the ring - flat side down - into the groove of the rotor core. When the retaining ring is seated into the groove, release the ring projections.
- (3) In order to insert the completed assembly in the cipher unit, hold the rotor in one hand and the cipher unit in the other. Tilt the cipher unit and allow the rotor to slide in over the shaft. Do not hold the cipher unit so that the shaft is vertical and drop the rotor straight down as damage may result.

DOCID: 3842901

~~CONFIDENTIAL~~

AFSAG 1236

CHAPTER 2

OPERATION

2000—KEYING INSTRUCTIONS

2001. Rotor Assembly and Arrangement.—The elements of each rotor are selected and assembled in accordance with the key list and each rotor is placed in the cipher unit as soon as assembly is complete. This is accomplished as follows, using the sample key list:

- a. Note that the key list contains eight numbered columns, one for each of the eight rotors. Select the core listed in the first column (7) and place any one of the alphabet rings on the core with the designated alphabet ring number (13) opposite the bench mark on the flat side of the core.
- b. Find the notch ring designated in the first column (6) and place it on the rotor so that its paired bench marks bracket the designated letter (G) of the alphabet ring.
- c. Place the retaining ring in position, check to see that the correct core, notch ring, and alignments have been set up, then insert the completed rotor assembly into the cipher unit *with the flat side in*.
- d. Repeat the process above for each of the rotors in turn. In the case of the wide ring assembly, which has no associated notch ring, align the appropriate number (23) appearing on the side of the wide ring to the bench mark of the designated core (2), and place the retaining ring in position. The wide ring is placed in the cipher unit by engaging the two lobes on the ring in the corresponding keyways in the frame of the cipher unit.

Note: The wide ring assembly is always the fourth listed in the key list and **MUST ALWAYS BE PLACED IN THE FOURTH POSITION IN THE CIPHER UNIT.**

- e. When all rotors have been assembled and inserted, place the side of the cipher unit in position, and close the slide catch. (*Note:* With all eight rotors in the cipher unit, the last rotor projects slightly from the unit and must be pressed in when positioning the side of the cipher unit.)

4. Use opposite page.

2002. 36-45 Check.

- a. The 36-45 letter check groups are provided in the key lists as a means of performing a check on the operation of the machine and upon the correctness of the rotor assembly and arrangement. The 36-45 check shall be made after each change of rotor assembly and arrangement. The check is made in the following manner:
 - (1) After the rotors have been assembled and placed in the machine, turn the controller to "P" and allow time for warm up. The cipher machine is ready for operation when the bulb lights after the "FIG" key is depressed. (Return to lower case by depressing the "LET" key.) *the keyboard will print.*
 - (2) Hold back the tape release lever to conserve tape and align the seven visible rotors to "AAAAAAA" by depressing in order each of the rotor-set keys. (The rotor-set keys are located below each rotor window when cipher unit is in place.)
 - (3) Turn the controller to "E." (Note that the rotor maze steps once.)
 - (4) Set the stroke counter to zero, press down the "Repeat" and "A" key simultaneously and hold until 45 letters have been printed.

~~CONFIDENTIAL~~

13

ORIGINAL

DOCID: 3842901

~~CONFIDENTIAL~~

AFSAG 1236

(5) Compare the last two groups of the resultant encipherment with the 36-45 check groups in the key list. If the groups are not identical, the above procedure should be repeated with all points carefully checked.

b. If the 36-45 check cannot be made successfully and rechecks have indicated that the rotor assemblies and arrangements are correct, dirty rotor or cipher unit contacts or faulty mechanical operation may be the cause of the trouble and appropriate corrective measures should be taken. The machine should not be used until the 36-45 check is correct in all respects.

2003. System Indicator and Message Classification.

- a. System indicators are the five-letter groups indicated in the key lists (or in a separate indicator list) which identify the specific POLLUX cryptosystem used for encipherment. The system indicator is *never* enciphered.
- b. The classification shall always be inserted in the beginning of each message within the first 25 letters of the plain text, and shall be enciphered as part of the message.

2004. Message Indicator.—The message indicator consists of five letters selected at random by the operator and is used to determine the *message rotor alignment* as explained in paragraph 2005. *The message indicator shall be different for each message or part.* When it is necessary, as in the case of a service, to reencipher a message, or part, or any portion thereof, a different message indicator shall be selected. Bona fide five-letter words, abbreviations, etc., shall not be used as message indicators under any circumstances.

Note: Do not deviate from this procedure in selection of message indicators. A random group must be selected, then aligned. *Do not step the rotors to a random alignment, and copy the result as the message indicator.*

2005. Message Rotor Alignment.—The alignment of the rotors at the beginning of encipherment or decipherment constitutes the message rotor alignment. The message rotor alignment is derived in the following manner:

- a. Select at random a five-letter message indicator and record it.
- b. With the controller at "P," align the first five rotors to the message indicator by depressing, in order, the rotor-set keys. Repeat the alignment of the first and second rotors on the sixth and seventh rotors, respectively. The seven-letter result is the message rotor alignment.

For example:

Message Indicator..... Q B D F P (selected at random)
 Message Rotor Alignment..... Q B D F P Q B

~~CONFIDENTIAL~~

ORIGINAL

DOCID: 3842901

~~CONFIDENTIAL~~

AFSAG 1236

2100—ENCIPHERING AND DECIPHERING

2101. Application of General Cryptoprocedures.—Instructions regarding the application of general cryptoprocedures such as arrangement of indicators and text, division of messages into cryptoparts and correction of typing errors are contained in the effective edition of AFSAG 1210 or AFSAG 1211. Messages should be divided into cryptoparts with each part containing not more than 350 groups of cipher text. Bisection and variable spacing are not required.

2102. Sequence of Operations in Encipherment.—After the message has been divided into parts, if necessary, it shall be enciphered in the following manner:

- a. Prepare the machine for operation in accordance with paragraphs 2001 and 2002, referring to the appropriate POLLUX key list to determine the rotor assembly, rotor arrangement, and the 36-45 letter check.

From a message indicator and determine the message rotor alignment in accord-

times and type the system

DO NOT ENCRYPT USING THIS SYSTEM ONLY.
 THIS SYSTEM GIVES TRUE INDICATOR IN CLEAR.
 REFER TO SUPPLEMENTARY INSTRUCTIONS.

~~SECRET~~

s.15(1)

SGT

occurs which will ...

followed by a space, repeat the last correct word ...

from that point. If the last group of cipher text does not contain any ...

"LET" key once and then encipher as many random letters as necessary to complete the group.

- g. After the text has been enciphered, switch the controller to "P," type the system indicator, advance the tape until the printing is clear of the tape channel, and tear off the tape.

2103. Sequence of Operations in Decipherment.

- a. Prepare the machine for operation in accordance with paragraphs 2001 and 2002, referring to the appropriate POLLUX key list (as indicated by the system indicator) to determine the rotor assembly, rotor arrangement, and the 36-45 check.
- b. Determine the message rotor alignment from the message indicator received and align it on the rotors in accordance with paragraph 2005.
- c. Turn the controller to "D." (Note that maze steps once as the controller passes from "P" to "E.")
- d. Set the stroke counter to zero.
- e. Type the cipher text of the message, exclusive of indicators. Disregard the spaces between groups. The plain text will be printed on the tape in word lengths. The letter "X" will always be printed in the place of "Z" and "Y" in place of "J," e. g., "XERO" for "ZERO" and "YUMP" for "JUMP."
- f. After completing decipherment, advance the tape until the printing is clear of the tape channel and tear off the tape.

~~CONFIDENTIAL~~

DOCID: 3842901

~~CONFIDENTIAL~~

AFSAG 1236

2200 - AIDS FOR DECIPHERING GARBLED MESSAGES

2201. General.—When a message garbles during decipherment, either from the beginning or after some plain text has appeared, the operator should first check his own work to insure that he has not made an error in setting up the machine or in typing. The possibility that the garble is caused by a typing error (such as an omission or repetition of a cipher letter) can be checked by noting the counter reading and resuming typing at the appropriate point in the cipher text. For example, if the counter reading is 38 when the garble is noticed, typing should resume with the 35th cipher letter. When the possibility of an error by the deciphering operator has been ruled out, corrective measures given below should be tried. All errors, except typing errors, shall be brought to the attention of the officer in charge of the cryptocenter who shall determine whether the error requires message or mail report as explained in the effective edition of AFSAG 1210 or AFSAG 1211.

2202. When No Plain Text Appears.

- a. *Missing or additional groups at the beginning of the message.*—Check the group count in the message heading against the actual number of groups.
 - (1) If one or more groups are missing, strike any letter key as many times as there are missing letters. Ignore the result, then decipher beginning with the first group.
 - (2) If one or more groups have been added, omit the indicated number of letters and decipher.
- b. *Error in the date-time group.*
 - (1) Try to decipher using the data given in the key list for the date preceding and then for the date following the date given in the date-time group.
 - (2) Try to decipher using the data given in the key list for the date of receipt and then for the date preceding and the date following the date of receipt.
- c. *Incorrect edition of key list.*—Try to decipher using the key list for the previous month and for the month following.
- d. *Incorrect message rotor alignment.*—Try to decipher using the alignment reached at the end of the 36-45 letter check.
- e. *Transposition of letters of the message rotor alignment in the alignment of the rotors.*—Transpose pairs of adjacent letters in the message rotor alignment when aligning rotors. The exchange of positions of two letters is most likely to occur when the result forms a pronounceable combination or when two letters are often used in reverse. For example, LULFELU aligned as LULEFLU.

2203. When Some Plain Text Appears.—Procedures in subsequent paragraphs involve the performance of certain operations with rotors aligned to the "point of garble." The point of garble is defined as the alignment reached by the rotors on decipherment of the last plain-text letter known or assumed to be correct.

- a. *Deletion of one or more groups.*
 - (1) If a check of the group count shows that one or more groups are missing, advance the rotors to the point of garble by striking any key the required number of times. Record the rotor alignment and the counter reading. Strike any key the same number of times as there are missing letters, ignore the result, then try to decipher.
 - (2) If this does not result in plain text, align the rotors to the point of garble as recorded in (1) above, then decipher the group following the point of garble as many times as necessary (without realigning the rotors) until plain text appears, checking for plain text after each decipherment. For example, if the garbled text starts at a counter reading of 95 (19 groups), decipher the 20th group as many times as necessary (without realigning the rotors) until plain text appears.

~~CONFIDENTIAL~~

16

ORIGINAL

DOCID: 3842901

~~CONFIDENTIAL~~

AFSAC 1236

b. Added or repeated groups.

- (1) If a check of the group count shows that one or more groups have been added or repeated, advance the rotors to the point of garble by striking any letter key the required number of times. Record the rotor alignment and the counter reading. Omit the indicated number of groups and continue to decipher.
- (2) If this does not result in plain text, decipher the 11th group following the garble as many times as necessary (without realigning the rotors) until plain text appears. Check each decipherment of the group for readable text. For example, if the recorded letter count at the point of garble is 205 (41 groups), decipher the 52d group as many times as necessary (without realigning the rotors) until plain text appears. If there are not 11 groups following the point of garble, decipher the next to the last group of the message as many times as necessary (without realigning the rotors) until plain text appears.
- (3) The number of extra groups can be determined by subtracting from 11 the number of times the 11th group was deciphered to produce plain text.

c. One letter of a six-letter group (made by defective spacing of the machine) is lost in handling.—Advance the rotors to the point of garble, strike any key once to replace the missing letter, and then decipher normally.

d. Cipher group consisting of only four letters.—Record the rotor alignment and the counter reading immediately before deciphering the four-letter group. Strike any letter key once to replace the missing letter, and then continue to decipher.

Note: In case an important word remains garbled in *c* or *d* above, realign to the point immediately preceding the group yielding garbles and decipher, striking any letter key in a different position until a logical word is obtained. If necessary, consult a Morse error chart for two-letter combinations commonly transmitted as one letter, or a teletypewriter garble table for letters frequently garbled into function control symbols. Substitute such letters in the cipher text and decipher.

e. Cipher group consisting of six letters.—(Occasionally a six-letter group will be printed because of machine fault, in which case all six letters will be required to get plain text.) Record the rotor alignment and the counter reading immediately before deciphering the six-letter group; then decipher all six letters of the group and continue to decipher several groups. If the result is a garble, decipher only the first five letters of the group, dropping the sixth, and continue to decipher several groups. If there is still a garble, drop other letters of the group one at a time until plain text results.

f. Two or more letters garbled in transmission causing an important word to be partially garbled.—Consult a Morse error chart or a teletypewriter garble table for letters commonly garbled in transmission. Substitute such letters in the cipher text and decipher.

g. One hand of the enciphering operator misplaced on the keyboard.—(Note that words when deciphered retain their correct length even though garbled.) Example: AIRCRAFT REOIRT-ED IOERATUBG IVER SOUTHERB AREA. (In this example the right hand of the enciphering operator was placed one position over from the correct position.) Observe the text as it appears on the tape. Fit in probable plain-text words and try to justify them by a particular misplacement of the operator's hand.

2204. Special AFSAM 7 Garbles.—Because of the number of elements involved, AFSAM 7 rotors are easily set up incorrectly. An error in core setting will produce completely undecipherable text and a service must be sent. If, however, a notch-ring is off-set, it may produce plain text for a short stretch before garbled text appears. The number of possible off-sets precludes trial-and-error attempts at correcting the alignment. A third characteristic error in AFSAM 7 text is caused by the "FIG" circuit becoming incorrectly activated. In this case, numbers will appear in place of the top row keys. When the "FIG" circuit is active, numerals will be produced in place of the letters associated with them (back row of keys).

~~CONFIDENTIAL~~

17

ORIGINAL

~~Reverse (Page 18) Blank~~

DIVULGUÉ EN VERTU DE LA LAI RENSEIGNEMENTS NON CLASSIFIES

DOCID: 3842901

AFSAO 1236

~~CONFIDENTIAL~~

3006. EMERGENCY DESTRUCTION

- a. The disassembly of rotors and the destruction of key lists, is essential. Destruction of AFSAO 107 and AFSAO 207 units, un-assembled rotors, and operating and maintenance instructions is desirable if time and circumstances permit. The destruction of the AFSAO 7 base is not required but should be accomplished if possible.
- b. Emergency destruction may be accomplished by disassembly and manual methods, or, if desired, by use of the M2A1 and AN-M14 incendiaries. When time and circumstances do permit the following procedures will for the manual destruction of the AFSAO 7.
 - (1) Disassemble each rotor by removing the retaining notch and alphabet rings.
 - (2) Destroy the wires within the core by unplugging them and then either cutting or ripping them loose. Access to the wiring may be gained by either removing the six screws from the face of the core or by smashing the rotor core.
 - (3) Remove the Stepping Control Unit from the machine and completely destroy it.
 - (4) The remainder of the AFSAO 7 shall be destroyed by whatever expedient means possible.
- c. When conditions permit, the remnants of the destroyed AFSAO 7 shall be burned by a M2A1 incendiary.
- d. When time and circumstances do not permit the manual destruction of the AFSAO 7 as outlined above, a M2A1 incendiary shall be placed on top of the machine and ignited.

3007. DESCRIPTION OF M2A1.--The M2A1 is a thermite incendiary similar to but smaller than the M1A1/M1A2. It is designed specifically for the destruction of the cipher machine SIGABA, and may be used to destroy the AFSAO 7 and other restricted cipher equipments not normally provided with M2A1's. The M2A1 measures 1 1/2" x 1", weighs approximately 1 1/2 pounds, and can be detonated by either manual or electrical means.

3008. INCENDIARY M2A1 (AN-M14).--Since igniters of many M2A1's now available are unreliable, two incendiary hand grenades (AN-M14) should be available for use in the event of ignition failure of the M2A1 during emergency destruction. The grenades should be requisitioned in accordance with Service procedures and utilized when necessary, in accordance with the instructions in Section 6300 of AFSAO 12104.

DOCID: 3842901

~~CONFIDENTIAL~~

AFSAG 1236

CHAPTER 3
PHYSICAL SECURITY

3000—GENERAL

3001. Custodian.—The custodian of AFSAM 7 and/or documents pertaining thereto shall be a commissioned or warrant officer except in situations where such assignment is impossible.

3002. Accounting.

- a. In accounting for rotors, an account for a particular set shall include rotors as assembled, i. e., rotor set AB 1 8 shall include not only the numbered cores 1 through 8 but also the 7 notch rings issued with those cores.
- b. Commands to whom bulk issue of material has been made will account to the appropriate issuing office for all material within the command according to current accounting procedures. For other commands, normal accounting will be required.

3003. Use and Transport in Aircraft.—Equipment and associated material for the AFSAM 7 may be used and transported in aircraft except that they may not be carried over communist or communist-controlled territory without specific authorization by the Chief of Staff, U. S. Army, Chief of Naval Operations, or Chief of Staff, U. S. Air Force.

3004. Other Physical Security Considerations.—The AFSAM 7 base cipher unit, rotor stepping unit, rotors, and other associated material will be given the maximum security possible under the circumstances to prevent unauthorized viewing and physical loss.

3005

3500. Clearances.—Cryptoclearance is not required for access to AFSAM 7, its component parts, or any associated POLLUX cryptomaterial. All personnel having access to the AFSAM 7 and its components will require clearance for information of at least a CONFIDENTIAL classification in accordance with Service instructions. CONFIDENTIAL clearance is required for access to SOI extracts. SECRET clearance is required for access to all other key lists.

3006. See opposite page

NOTE: It must be remembered that this additional information does not constitute permanent procedure. Permanent procedures for the destruction of rotors, ASBAM 107 and AFSAM 207 units, and the AFSAM 7 base by manual disassembly methods are being prepared and will be included in appropriate instructional documents.

~~CONFIDENTIAL~~

DIVULGUÉ EN VERTU DE LA LAI RENSEIGNEMENTS NON CLASSIFIÉS

DOCID: 3842901

2025 RELEASE UNDER E.O. 14176

DOCID: 3842901

~~CONFIDENTIAL~~

AFSAG 1236

CHAPTER 4

4000—REPORTING VIOLATIONS

4001. General.—Violations of physical and cryptosecurity in POLLUX cryptosystems shall normally be reported by following the instructions in the effective edition of AFSAG 1210 or AFSAG 1211. *Only* when the effective edition of AFSAG 1210 or AFSAG 1211 is not held, violations shall be reported in accordance with the procedures below.

4002. Action by Reporting Stations.—When any of the violations listed in Section 4100 occur, the reporting station shall send a message report to the next higher headquarters holding the effective edition of AFSAG 1210 or AFSAG 1211 for action.

- a. The message shall be classified CONFIDENTIAL.
- b. The message shall be assigned a DEFERRED precedence unless it concerns a physical compromise or a violation involving faulty reencryption in which case the message shall be assigned a PRIORITY precedence.
- c. Contents of message reports shall be as follows:
 - (1) State the nature of the violation.
 - (2) Include the short title and edition designator of the cryptomaterial involved.
 - (3) Include the date-time group, the means of transmission, the originator, and the addressee(s).
 - (4) List all reencryptions, retransmissions, and services involved. If there were none, state "NO LINKAGE."
 - (5) Give the length of the message(s) involved.
 - (6) In the case of physical compromise, briefly state the circumstances and indicate the probability of compromise by using one of the following statements: COMPROMISE CERTAIN, COMPROMISE PROBABLE, COMPROMISE IMPROBABLE, or COMPROMISE IMPOSSIBLE (as in known destruction by fire).
- d. Send (by mail or courier) a copy of each message involved *exactly* as transmitted. Include copies of all services, reencryptions, and retransmissions involved. These copies shall be classified CONFIDENTIAL and shall be sent to the same headquarters as that to which the message report was sent.

4003. Action by Higher Headquarters on Receipt of Message Reports.

- a. Refer to the effective edition of AFSAG 1210 or AFSAG 1211 and determine the specific type of report required. Forward such reports as directed in those documents.
- b. If the reporting station did not include sufficient information to make a full report to the Director, National Security Agency, send an interim report and request the necessary amplification from the reporting station (or, if more appropriate, from the violating station).
- c. On receipt of copies, forward them to the Director, National Security Agency, if the specific violation so requires.

~~CONFIDENTIAL~~

ORIGINAL

DOCID: 3842901

~~CONFIDENTIAL~~

AFSAG 1236

4100—SPECIFIC VIOLATIONS

4101. General. Reports of the violations below should contain, in addition to the specific information required in paragraph 402c, all relevant information which can aid in the evaluation of the seriousness of the case. Violations to be reported are as follows:

- a. *Any physical compromise.*
- b. Failure to comply with any of the instructions pertaining to selection and use of message indicators (par. 2004). State the circumstances. For example, if a message indicator was re-used, state how many times, and for what purpose. If the message indicator was nonrandom, what was used—a bona fide word? Was an alignment used which was reached by the rotors during any phase of operation?
- c. Faulty rotor stepping. (Do not use the machine until it has been repaired if more than one faulty step is observed.) If the rotors did not move at all, monoalphabetic substitution may have resulted and all addressees must be informed that the message must be considered compromised and that it shall not be serviced.
- d. Transmission in the clear of any alignment reached by the rotors during any phase of operation.
- e. Transmission of a message or cryptopart containing more than 350 groups. (State the number of groups the message contained.)

~~CONFIDENTIAL~~

ORIGINAL

DOCID: 3842901

~~CONFIDENTIAL~~

AFSAG 1236

CHAPTER 5

MAINTENANCE INSTRUCTIONS FOR INTERMEDIATE REPAIR FACILITIES

5000—PREPARATION FOR USE

5001. General.—The instructions in this chapter are presented primarily for the use of personnel who have had no formal training in the maintenance of the AFSAM 7. If followed, the procedures outlined below will enable untrained personnel to perform emergency repairs on the equipment by substituting component assemblies. Instructions on preventive maintenance and cleaning are also included.

5002. Storage.—When not in use, store the AFSAM 7 in its carrying case (fig. 1). This will protect it and keep it clean.

5003. Unpacking the Equipment.—Use the following procedure to unpack the AFSAM 7:

- a. Place the carrying case right side up and remove the metal shipping band.
- b. Unfasten the six cover holding latches (fig. 1(1)), and remove the cover by raising it vertically.
- c. Tip the case downward to the operating position (fig. 1). Place the cover on top of the carrying case, with the copy holder uppermost.

5004. Initial Inspection.—Inspect the AFSAM 7 and its accessories for any signs of damage or omissions as soon as it is unpacked. All cases of damage during shipment, or failure of the cipher machine to operate in accordance with the test given in paragraph 5006 should be reported in detail to the office of issue through normal Service channels.

5005. Installation Procedure.—Following the initial inspection of the equipment, the AFSAM 7 is to be prepared for operation in the following manner:

- a. *Cleaning Rotors.*—Thoroughly clean the surfaces of the flat head contacts of the rotors (fig. 4(2)) with a dry, rough, lint-free cloth. Clean the rotor pressure contacts (fig. 4(6)) by polishing them with the canvas cleaning block assembly (fig. 6(6)).
 - (1) Put a small amount of Lubriplate #105 (fig. 6(4)) on a piece of Twilljean (fig. 6(2)) or any other lint-free cloth. Fold the cloth, and rub it gently between the fingers so as to work the lubricant into the fabric.
 - (2) Wrap the cloth around the end of a finger and rub the cloth lightly over the surface of the rotor flat head contacts (fig. 4(2)).
 - (3) No definite time schedule is established for relubrication of the rotors since it is dependent on operating conditions. However, when the rotors become dirty or dry, repeat the cleaning and lubricating procedures.
 - (4) Do not use chemicals to clean the rotors or any other plastic parts. They might have an injurious effect on the material.
- b. *Placement of Rotors.*—The rotors (fig. 5(2) and (19)) are placed in the cipher unit assembly shell (fig. 4(13)) so that when the cipher unit is completely assembled, the rotor pressure contacts face toward the right-hand end plate assembly (fig. 5(18)).

Note: See paragraph 5203 for instructions regarding the removal and replacement of the cipher unit.

~~CONFIDENTIAL~~

ORIGINAL

DOCID: 3842901

~~CONFIDENTIAL~~

AFSAG 1236

- (1) Place the first three rotors on the shaft in their proper sequence (see par. 2001), and slide them into the shell.
 - (2) Next, place the stationary rotor (fig. 5(2)) on the shaft, and position it so as to align its tabs with the two machined keyways in the shell. One of these keyways is of greater width, insuring proper alignment.
 - (3) Place the remaining four rotors on the shaft in their proper sequence, and slide them into the shell. The last rotor will have a tendency to remain outside the shell.
 - (4) Place the right-hand end plate assembly on the shaft, and compress the rotors into the shell until the right-hand end plate latch (fig. 5(3)) can be engaged in the machined groove on the rotor shaft, thus locking the rotors within the shell.
 - (5) The end plate assemblies of the cipher unit extend through the stepping unit and make connection with pressure contacts (fig. 5(8)) on the contact panel. *Take care that these contacts and the end plate assemblies are not damaged during removal or installation of the cipher unit.*
 - (6) Replace the cipher unit.
- c. *Installation of Typewriter Ribbon.*—The typewriter ribbon is contained on two metal ribbon spools (fig. 2(10)). It is fed down and around the figured wheel (fig. 1(9)) in the ribbon track. Initial installation of the ribbon may differ in appearance from the normal operating track-age because of the direction in which the ribbon is wound during manufacture. The driving action of the mechanism is such that both spools rotate counterclockwise. The ribbon reversing mechanism is so designed that after the ribbon has once been completely unwound from the new metal spool, the normal route of the ribbon will be assumed automatically. The ribbon is normally unwound from the top right of the left-hand spool, and travels down around the ribbon track and up to the top right of the right-hand spool. The new ribbon is installed in the following manner:
- (1) Raise the latches of the two ribbon spools and withdraw the spools from the shafts of the reel drive plates. Disconnect the ribbon from the empty spool.
 - (2) Unwind approximately 8 inches of ribbon from the new full spool, and attach this spool to the left reel drive plate.
 - (3) Attach the free end of the ribbon to the empty metal spool. The ribbon should be threaded onto this spool from the top right. Make sure that the free end of the ribbon is passed through the hub of the spool and up onto the serrated teeth which should pierce the ribbon. In this manner, the pull of the ribbon is constantly against the serrated teeth, and will not loosen when the end of the ribbon is reached and the direction of travel reversed. Attach the empty spool to the right reel drive plate.
 - (4) Rewind any excess slack in the ribbon onto the free-running spool.
- d. *Installation of Paper Tape.*—The roll of paper tape is housed in the paper tape container (fig. 1(10)) at the right side of the printer assembly. It is positioned under the figured wheel by means of a guide block and paper tape guide. The roll of paper tape is installed in the following manner:
- (1) Release the spring hood assembly by turning the swivel pin assembly 90 degrees (fig. 3(18)). Restrict the upward travel of the spring hood with the right hand.
 - (2) Flatten the roll of tape by tapping it against the carrying case or any other suitable flat object.
 - (3) Tear off the first wrap of tape and discard it. Unroll approximately 1 foot of tape.
 - (4) Place the roll of tape between the sides of the paper tape container. The end of the tape should come off the bottom of the roll with the gummed side up.
 - (5) Depress the roll of tape into the paper tape container, and secure the spring hood assembly by means of the swivel pin assembly.

~~CONFIDENTIAL~~

ORIGINAL

DOCID: 3842901

CONFIDENTIAL

AFSAG 1236

- (6) Form the free end of the tape around the guide block of the paper tape container, and pull the tape until it is taut and extends past the paper tape feed roll (fig. 2(8)).
- (7) Hold the tape around the guide block and thread the end of the tape through the paper tape guide, with the gummed side of the tape down.
- (8) Push inward against the feed roll follower assembly (fig. 2(9)), and slide the tape between the paper tape feed roll (fig. 2(8)) and the feed roll follower. Release the feed roll follower assembly, allowing it to ride on top of the paper tape feed roll, holding the tape in place.
- (9) Check the tape to see that it is smooth and unwrinkled. Push inward against the feed roll follower assembly, and take up any slack in the tape. Release the feed roll follower assembly and tear off the excess tape by grasping the loose end and pulling upward and outward with a sharp motion.

e. *Connecting Power Supply.*—The AFSAM 7 is designed to operate from a voltage supply of 21 to 31 volts DC. The source of power must be checked to see that it is capable of supplying power within the specified limits. After checking the power, connect the AFSAM 7 to the power source by means of the power cable. See paragraph 5108. *The current consumption of the AFSAM 7 is 2.5 amperes.*

5006. *Test Procedure.*—The following test procedure is to be used in the initial set-up of the equipment, to check the operation of the AFSAM 7 following any prolonged period of time during which the cipher machine has not been operated, and also for the diagnosis of trouble in the equipment. While not infallible, it will, in the majority of cases, localize trouble to major components. The test is designed to check the cipher machine—not particular keying elements. The test sequence listed below must be followed, or the trouble chart in paragraph 5301 will not apply. The procedure is arranged so that once a component has been checked for proper operation it may be eliminated as a possible source of trouble in any subsequent test steps. During the test, as during the normal operation of the cipher machine, typing at speeds in excess of 60 words per minute will result in malfunctioning of the equipment and the dropping of characters in the reproduced text. In the event that improper results are obtained during any of the following test steps, refer to paragraph 5301 for the appropriate trouble-shooting procedures.

a. *Plain Text.*—With the external power supply connected to the AFSAM 7, turn the selector handle (fig. 3(13)) from the O (off) to the P (plain) position. The motor generator will start and run continuously, and the figured wheel will rotate in a clockwise direction as viewed from the front. Wait approximately 15 seconds for the tubes to warm up.

- (1) Depress the FIG key. The neon glow lamp (fig. 5(9)) should light.
- (2) Depress the LET key. The glow lamp should go out.
- (3) Set the counter (fig. 3(9)) to zero.
- (4) Type the following test sentence: THE 236TH QUICK RED FOX JUMPED 780 TIMES OVER 1459 LAZY BROWN DOGS. The reproduction on the paper tape should be the same, and the counter should register 66.
- (5) Mark this part of the paper tape “#1.”
- (6) Depress the X key and then the RPT key. The machine should print a continuous line of X's in a rhythmical manner. There should be no blank character spaces between the X's.
- (7) Depress one of the seven set keys (fig. 2(5)).
 - (a) Hold the set key depressed. Its associated rotor should step continuously, in a rhythmical manner.
 - (b) Momentarily depress and release the set key. The associated rotor should step one position only.
 - (c) Repeat steps (a) and (b) above until the rotor has completed three revolutions.
- (8) Repeat the steps in subparagraph (7) above for each of the six remaining set keys.

CONFIDENTIAL

25

ORIGINAL

DIVULGUÉ EN VERTU DE LA LAI RENSEIGNEMENTS NON CLASSIFIÉS

DOCID: 3842901

~~CONFIDENTIAL~~

AFSAG 1236

b. Encipher.

- (1) With the selector handle in the P position, set the seven rotors to A by means of their respective set keys.
- (2) Turn the selector handle from the P to the E (encipher) position.
 - (a) The cipher machine should cycle once.
 - (b) The paper tape mechanism should feed the paper tape one space.
 - (c) There should be no printing on the paper tape.
 - (d) At least three of the rotors should step one position.
- (3) Set the counter to zero.
- (4) Depress the X key and then the RPT key, and hold them depressed until the counter registers 1000. The cipher machine should print 200 groups of 5 letters each.
- (5) Mark this part of the paper tape "#2."
- (6) Note the reading of the seven rotors with reference to the cipher unit index marks on the shell (fig. 1(4)). Record the reading on the end of tape #2.
- (7) Turn the selector handle from the E to the P position. The machine should cycle once.
- (8) Repeat steps (1) through (4) above.
- (9) Mark this part of the paper tape "#3."
- (10) Compare the reading of the seven rotors with that obtained in step (6) above. They should be identical.
- (11) Compare paper tapes #2 and #3. They should be identical.
- (12) Turn the selector handle from the E to the P position.
- (13) Repeat steps (1) through (3) above.
- (14) Type the sample sentence given in subparagraph *a* (4) above. The cipher machine should print fourteen 5-letter groups with a group of 2 letters at the end. The glow lamp should light each of the three times the FIG key is depressed, and go out each time the LET key is depressed. The counter should register 72.
- (15) Mark this part of the paper tape "#4."

c. Decipher.

- (1) Turn the selector handle from the E to the P position.
- (2) Repeat steps (1) through (3) in subparagraph *b* above, except that in step (2) turn the selector handle from the P to the D (decipher) position.
- (3) Type the enciphered version of the test sentence as reproduced on the part of paper tape marked "#4." The glow lamp should go on and off three times during the typing. The cipher machine should reproduce the test sentence in subparagraph (4) below.

Note: " " indicates one space.
- (4) THE -- 236-TH-QUICK-RED-FOX-YUMPED -- 780 -- TIMES-OVER -- 1459--LAXY-BROWN-DOGS.
- (5) The counter should register 72.

Note: The space bar will not operate in decipher.

d. Conclusions.—The test procedure above determines that the cipher machine is operating correctly.

5007. Operation of AFSAM 7 in the Office Case.—The operation of the AFSAM 7 in its office case (fig. 2) is essentially the same as operation in the carrying case. Subparagraphs 5201a(1) and b(2) contain instructions on the removal of the AFSAM 7 from its carrying case and installation of the machine in the office case. After the machine is secured in the office case, perform the test procedure given in paragraph 5006.

~~CONFIDENTIAL~~

ORIGINAL

DOCID: 3842901

~~CONFIDENTIAL~~

AFSAG 1236

5008. Errors in Reproduction.—The two classes of errors which may cause the cipher machine to function incorrectly are operational and functional.

- a. *Operational Errors.*—Operational errors are due to mistakes made by the operator in either setting up or operating the equipment. They can be largely eliminated by the use of proper care on the part of the operator.
- b. *Functional Errors.*—Functional errors consist principally of troubles due to maladjustments, dirty contacts, short or open circuits, or power failures. If the operator cannot correct the functional errors by component assembly replacement, the equipment should be sent through normal Service channels to a higher echelon for the necessary repairs. Rotors should be cleaned and lubricated in accordance with the instructions in subparagraph 5005a before being used.

5009. Transporting AFSAM 7 On Packboard.—The AFSAM 7 in its carrying case is easily transported on the standard packboard. To lash the unit to the packboard, follow the instructions outlined below.

- a. Be sure that the canvas on the packboard is tight, and adjust the shoulder straps so as to keep the load high and comfortable.
- b. Lay the packboard on the ground with the shoulder straps down and remove the lashing rope from the board.
NOTE: The lashing rope is normally used to secure the AFSAM 7 carrying case to the packboard. However, if rope is not available, field wire or any other field expedient may be used.
- c. Slide the AFSAM 7 completely into the carrying case, place the cover in position, and fasten the six cover holding catches.
- d. Lay the carrying case on its side on the upper portion of the packboard in such position that it will be carried upright with the carrying case handle folded away from the packboard (see fig. 7).
NOTE: It is important that the case be positioned on the packboard as outlined above so as to provide even distribution of the load.
- e. Lash the carrying case to the packboard, weaving the rope back and forth and diagonally across the board. No detailed method of lashing is given here since there are numerous methods. Pull the lashing rope as tight as possible to prevent any shifting of the case. Use knots which are easy to untie.
CAUTION: Do not drop the loaded packboard to the ground.
- f. Wind the lashing rope around the top of the board when not in use.

~~CONFIDENTIAL~~

27

ORIGINAL

DOCID: 3842901

~~CONFIDENTIAL~~

AFSAG 1236

5100--COMPONENT ASSEMBLIES

5101. Cipher Machine.—The AFSAM 7 is composed essentially of the following assemblies: a base, keyboard with the sliding contact board and guide rail, contact panel, printer, stepping unit, and cipher unit.

5102. Base Assembly.—The magnesium base assembly (fig. 5(12)) forms a supporting frame on which the other components of the cipher machine are mounted. Tracks machined along its four sides, and two attached brackets provide shock mounting within the carrying case. Pads and inserts are positioned throughout the base to provide the means of locating, fastening, and supporting the other components. The tracks at the front corners engage a double set of shock mounts in the carrying case, providing maximum support at these points. Four inserts in the corners provide for mounting the base within an office case. A spring-loaded stop pin projects through the bottom of the case. When the cipher machine is drawn forward in the carrying case, the spring-loaded stop pin engages the slot in the carrying case spring stop. This limits the cipher machine to its operating position, and prevents unintentional withdrawal. Depression of the spring stop allows full removal of the cipher machine.

5103. Keyboard Assembly.—The keyboard assembly (fig. 3(12)) is located at the front of the cipher machine, and is removable as a unit. It functions as a typing keyboard, and, in conjunction with a sliding contact board assembly, establishes the various circuits of the cipher machine. The keyboard assembly is mounted directly on the contact panel assembly (fig. 5(11)), and is therefore insulated from the base of the cipher machine. A power cable and cover plate assembly (fig. 1(7) and 3(11)) and two fuse holder assemblies (fig. 3(10)) located at the right end of the keyboard assembly provide the means of introducing electrical power to run the cipher machine. The sliding contact board and guide rail assembly (fig. 4(3)) lies directly below the keyboard assembly, above the forward area of the contact panel assembly. It functions as a four-position, multicircuit switching device, and, as far as this publication is concerned, will be discussed as part of the keyboard assembly.

5104. Contact Panel Assembly.—The contact panel assembly (fig. 5(11)) is attached directly to the cipher machine base. It provides the interunit wiring of the cipher machine, contains the fixed contacts that establish the interunit connections, carries the various electrical circuit components, and is the mounting base to which the keyboard is secured.

5105. Printer Assembly.—The printer assembly (fig. 3(19) and 4(7)) is mounted on the left side of the base assembly by means of four captive mounting screws, and is removable as a unit. It provides the mechanical power for the cipher machine, the high voltage used in the electronic circuits, and the precisely-timed electrical pulses which initiate the printing of characters on a paper tape. It also provides automatic opening and closing of predetermined circuits at the proper times, and automatically spaces the paper tape and the inked ribbon.

5106. Stepping Unit Assembly. The stepping unit assembly (fig. 3(5) and 4(15)) is mounted at the right center of the cipher machine, and is removable as a unit. It also may be removed with the cipher unit attached. It automatically steps the rotors of the cipher unit in a definite pattern during encipherment and decipherment, and provides a means of stepping rotors individually by means of the rotor set keys. A counter mounted on the front of the rotor stepping unit records each cycle made by the cipher machine.

5107. Cipher Unit Assembly.—The cipher unit assembly (fig. 2(3) and 3(7)) is attached to the stepping unit by means of the right- and left-hand cipher unit latches (fig. 2(4)) which engage the rotor shaft. It provides the means for enciphering characters in a definite but unrecognizable pattern by means of eight (seven movable and one stationary) rotors which are housed within the unit. Since there is a definite pattern to the enciphered version, the cipher unit assembly also provides the means for deciphering characters in the same sequence.

~~CONFIDENTIAL~~

ORIGINAL

DOCID: 3842901

~~CONFIDENTIAL~~

AFSAG 1236

5108. AC Power Converter Assembly.—The AC power converter assembly (fig. 1(6) and 3(3)) is designed to supply 21 to 31 volts DC for operation of the AFSAM 7. The power converter selector switch, located on top of the power converter (fig. 3(4)) may be set to allow operation of the converter using either a 100-125 or a 200-250-volt, 50-60-cycle, AC input power source. One side of the input to the power converter is fused to prevent injury to the circuits by accidental connection to a 200-250-volt power source when the selector switch is set for 100-125 volts. The other fuse holder on the converter contains a spare fuse (fig. 3(2)). *The current consumption of the AFSAM 7 is 2.5 amperes.*

5109. Carrying Case Assembly.—The carrying case assembly (fig. 1(11)) is designed so that the cipher machine may be operated while partially within the case. It provides a shock- and water-resistant container for transporting the cipher machine either by hand or on a standard pack board. Fittings within the case provide a copy holder (fig. 1(2)), and storage for the operating light, cable, additional paper tape (fig. 1(3)), and spare typewriter ribbons.

5110. Accessories and Case Assembly.—The accessories and case assembly resembles the carrying case in outward appearance. However, it is equipped with interior fittings for storage of accessory and spare equipment for the AFSAM 7. The contents of the accessories case vary with the installation where it is employed. The fully equipped accessories case normally contains the following equipment: a base assembly on which the various components are mounted and in which is a drawer, an AC power converter assembly, a stepping unit assembly, and two cipher unit assemblies.

5111. Office Case Assembly.—The office case assembly (fig. 2) provides a means of storing and transporting the AFSAM 7 under office conditions where the risk of damage from blows or exposure is less than under field conditions. The case is made of aluminum and does not contain sealing gaskets or shock mounts. The AC power converter assembly (see par. 5108) is mounted inside the case, at the rear, with an attached cable for connecting to a standard AC receptacle. The power cable for the cipher machine attaches to the converter inside the case. The double-hinged cover (fig. 2(2)) folds back to provide a rack for holding copy (fig. 2(1)).

~~CONFIDENTIAL~~

ORIGINAL

DOCID: 3842901

~~CONFIDENTIAL~~

AFSAG 1236

5200—SUBSTITUTION OF COMPONENT ASSEMBLIES

CAUTION: BEFORE PERFORMING MAINTENANCE OF ANY TYPE, TURN THE SELECTOR HANDLE TO THE O POSITION, AND DISCONNECT THE POWER CABLE FROM THE POWER SOURCE.

5201. General.—Before undertaking the removal or substitution of component assemblies, it may be necessary to remove the cipher machine from its case.

a. Carrying Case.—The cipher machine must be removed from the carrying case for removal of all components except the keyboard assembly.

- (1) To remove the cipher machine from the carrying case (fig. 1), press down on the stop spring which is mounted on the inner bottom of the case, and withdraw the cipher machine.
- (2) To replace the cipher machine in the carrying case, position the machine so that the two grooves in the bottom of the machine ride on the two bottom rails in the carrying case, depress the stop spring, and slide the machine into the case.

b. Office Case.—The cipher machine should be removed from the office case for removal of all components except the keyboard assembly, cipher unit, and stepping unit.

- (1) To remove the cipher machine from the office case (fig. 2), fold the cover of the case to its full rearward position. Disconnect the cipher machine and power converter cables (fig. 2(6)). Remove the four mounting nuts on the bottom of the case, and lift the cipher machine out of the case.
- (2) To replace the cipher machine in the office case, fold the cover of the case to its full rearward position. Place the machine in the case so that the four mounting studs fit into the holes on the bottom side of the case, and replace the four lock washers and mounting nuts. Tighten the nuts, and connect the cipher machine and power converter cables.

5202. Keyboard Assembly.

a. To remove the keyboard assembly (fig. 3(12) and 4(4)), turn the selector handle (fig. 3(13)) to the D position, loosen the five keyboard assembly captive screws (fig. 3(14)) using the 1/8-inch plastic handle Allen key (fig. 6(9)), and lift the assembly from the contact panel. If done with care, the sliding contact board will remain in position on the contact panel without further disassembly.

CAUTION: IF THE KEYBOARD ASSEMBLY IS NOT LIFTED VERTICALLY, THE SLIDING CONTACT BOARD AND GUIDE RAIL ASSEMBLY ALSO MAY BE LIFTED FROM THE CONTACT PANEL AND THEN DROPPED. THIS MAY RESULT IN DAMAGE TO THE SLIDING CONTACT BOARD ON THE CONTACT PANEL.

b. To replace the keyboard assembly, pull up on each of the five captive screws and turn them counterclockwise until they screw up slightly into the keyboard housing. Make sure the sliding contact board guide rail assembly is up. Carefully place the contact board on the contact panel in such a position that the left ends of the guide rails are in line with the follower assembly (plunger assembly below the tape feed wheel.)

c. Carefully replace the keyboard assembly on the contact panel.

NOTE: It may be necessary to move the selector handle slightly so that the keyboard assembly will seat itself properly.

d. Tighten the captive screws.

5203. Cipher Unit Assembly.

a. To remove the cipher unit assembly, lift up on the right- and left-hand cipher unit latches (fig. 1(5)), and lift the cipher unit assembly vertically from the stepping unit.

b. To replace the cipher unit, carefully place it on the stepping unit with the rotor windows facing the front of the machine. Push downward on the cipher unit and hook the cipher unit latch down over the rotor shaft. Press down on the cipher unit latch locking the rotor shaft in position.

DOCID: 3842901

~~CONFIDENTIAL~~

AFSAG 1236

5204. Stepping Unit Assembly.

- a. To remove the stepping unit, loosen the two captive thumb screws (fig. 1(8) and 3(8)) and lift the unit upward and slightly toward the front of the cipher machine.
- b. To replace the stepping unit, tilt it backward at approximately a 45-degree angle and engage the slots in the stepping unit blocks with the slots in the mounting blocks on the base of the cipher machine. Be sure that the rotor stepping crank (fig. 4(16)) fits into the yoke of the drive link assembly (fig. 4(8)), and lower the unit into place.

CAUTION: CARE MUST BE TAKEN NOT TO BEND THE PLUNGER CONTACTS ON THE CONTACT PANEL ASSEMBLY.

- c. Tighten the captive thumb screws.

5205. Printer Assembly.

CAUTION: WHEN HANDLING THE PRINTER ASSEMBLY, DO NOT GRASP SUCH PARTS AS THE PRINT MAGNET (fig. 2(7)), TIMING CAM SWITCHES (fig. 4(9)), OR CLUTCH TRIP MAGNET (fig. 3(17)). THESE PARTS HAVE SOLDERED ELECTRICAL CONNECTIONS AND DELICATE ADJUSTMENTS. HOLD THE PRINTER ASSEMBLY BY ITS HOUSING (fig. 3(19)).

- a. In order to remove the printer assembly, the rotor stepping unit (par. 5204) and the left-hand support bracket (subpar. b below) must first be removed.
- b. To remove the left-hand support bracket (fig. 3(20)), loosen the three rear bracket captive screws (fig. 3(15)) with the $\frac{3}{16}$ -inch T-handle Allen key (fig. 6(7)) and the front bracket captive screw with the $\frac{3}{16}$ -inch-L-shaped Allen key (fig. 6(8)).
- c. To remove the printer assembly, loosen the four printer assembly captive screws (fig. 3(16) and 4(11)) with the $\frac{3}{16}$ -inch T-handle Allen key (fig. 6(8)), and lift the printer assembly vertically from the contact panel.
- d. To replace the printer assembly, position the printer so that the four studs on the assembly line up with the four inserts on the base assembly, and tighten the four printer assembly captive screws into the inserts.

5206. Contact Panel Assembly.

CAUTION: WHEN HANDLING THE CONTACT PANEL ASSEMBLY (fig. 5(11)), GRASP IT BY ITS EDGES. BE CAREFUL NOT TO EXERT ANY PRESSURE OR FORCE ON THE ELECTRICAL WIRING OR ELECTRICAL COMPONENTS MOUNTED ON ITS LOWER SURFACE. EXERT NO SIDEWAYS PRESSURE ON THE EXPOSED TIPS OF THE PRESSURE CONTACTS. WHEN PLACING THE ASSEMBLY FLAT ON A TABLE OR BENCH, SUPPORT IT NEAR THE FOUR CORNERS SO THAT THE ELECTRICAL COMPONENTS DO NOT REST DIRECTLY ON THE BENCH TOP.

- a. Before the contact panel assembly can be removed, it is necessary to remove the following components: keyboard assembly and sliding contact board, cipher unit, stepping unit, ~~left- and right-hand support brackets (fig. 3(6) and (20))~~, and the printer assembly (see par. 5201 thru 5205).
- b. To remove the contact panel assembly (fig. 5(11)), loosen the six contact panel mounting screws (fig. 5(13)) with the $\frac{3}{32}$ -inch plastic handle Allen key (fig. 6(10)) and lift the contact panel vertically from the base.

~~CONFIDENTIAL~~

31

ORIGINAL

DOCID: 3842901

~~CONFIDENTIAL~~

AFSAG 1236

- c. To replace the contact panel assembly, place it flat on the base and tighten the six contact panel mounting screws.

Note: Be sure that the electrical wiring is not pinched between the contact panel assembly and the metal supporting and mounting studs.

- d. When replacing a defective contact panel assembly with a new one, it is necessary to transfer the neon glow lamp (fig. 5(9)) and the six tubes (fig. 5(4), (5), (6), (7), (16), and (17)) from the old to the new contact panel assembly.
- (1) To remove the neon glow lamp, unscrew the plastic cover, twist the lamp counterclockwise, and lift it from the socket.
 - (2) To replace the glow lamp, insert it in its socket so that the projections on the lamp line up with the slots in the socket, push the lamp downward, and twist it clockwise until it is locked in place. Screw on the plastic cover.
 - (3) To remove the tubes, first remove the metallic shields by depressing them and turning them counterclockwise until they can be lifted off vertically. Then, grasp each tube firmly and pull it out of its socket.
 - (4) To replace the tubes, match the projecting pins on the bottom of each tube with the holes in the tube socket, and press the tube down firmly until it is properly seated. Replace the metallic shields.

5207. AC Power Converter Assembly.

- a. To remove the AC power converter (fig. 1(6)) from the office case:
- (1) Disconnect the power cable (fig. 2(6)) from the cipher machine to the power converter.
 - (2) Unwind the input power cord from the rear of the case.
 - (3) Loosen the four power converter captive thumb screws (fig. 3(1)), and withdraw the power converter from the office case.
- b. To replace the AC power converter in the office case:
- (1) Thread the AC power cord through the hole in the rear of the office case.
 - (2) Place the power converter in position and tighten the captive thumb screws.
 - (3) Connect the power converter power cable (fig. 2(6)) to the cipher machine power cable.

CONFIDENTIAL

32

ORIGINAL

DOCID: 3842901

~~CONFIDENTIAL~~

AFSAG 1236

5300--TROUBLE SHOOTING

5301. **Simplified Trouble-Shooting Chart.**—Following is a simplified trouble-shooting chart. This trouble-shooting chart is to be used only in conjunction with the test procedure outlined in paragraph 5006. This is not a complete trouble chart. Its main purpose is to associate the troubles as indicated in the test with the major component most commonly responsible. The troubles and remedies are indexed by the test paragraph number within which the trouble will be noted. Instructions pertaining to the removal and replacement of component assemblies are contained in section 5200 of this document.

*Test Par.
No. 5006*

Trouble and Remedy

- a. Motor does not operate
1. Check power cable terminal connections
 2. Replace fuses
 3. Replace power supply
 4. Check and clean contacts under keyboard assembly
 5. Check and clean contacts on both sides of sliding contact board
 6. Check and clean contacts under printer assembly
 7. Replace assemblies found with defective contacts
 8. Replace printer unit
 9. Replace keyboard assembly
 10. Replace sliding contact board
 11. Replace contact panel assembly
- Motor overspeeds
1. Replace printer assembly
 2. Replace power supply
- a(1) Neon glow lamp does not light
1. Replace neon glow lamp
 - * 2. Replace shift tube
 3. Check and clean contacts under keyboard assembly
 4. Check and clean contacts on both sides of sliding contact board
 5. Check and clean contacts under printer assembly
 6. Replace components which have defective contacts
 7. Replace printer assembly
 8. Replace contact panel assembly
- a(2) Neon glow lamp does not go out
- * 1. Replace shift tube
 2. Check and clean contacts under keyboard assembly
 3. Check and clean contacts on both sides of sliding contact board
 4. Replace keyboard assembly
 5. Replace sliding contact board
 6. Replace contact panel assembly
- a(3) Counter does not reset
1. Replace stepping unit

~~CONFIDENTIAL~~

33

ORIGINAL

See Note, pp. 80

DOCID: 3842901

CONFIDENTIAL

AFSAG 1236

*Test Par.
No. 5006*

Trouble and Remedy

a(4).....No printing on tape

- * 1. Replace print tube
- 2. Replace sharpener tube
- * 3. Replace gate tube
- 4. Replace printer assembly
- 5. Replace keyboard assembly
- 6. Replace sliding contact board
- 7. Replace contact panel assembly

Poor quality of printing

- * 1. Replace print and sharpener tube
- 2. Replace printer assembly
- 3. Replace contact panel assembly

Dropped characters--do not print

- 1. Check and clean contacts under keyboard
- 2. Check and clean contacts on both sides of sliding contact board
- 3. Check and clean contacts under printer assembly
- 4. Replace components which have defective contacts

No spacing on tape

- 1. Replace printer assembly

Poor spacing on tape

- 1. Check paper tape for sticking
- 2. Flatten paper tape roll
- 3. Replace printer assembly

Letters print instead of numerals

- * 1. Replace shift tube
- 2. Replace printer assembly
- 3. Replace contact panel assembly

Repetitive printing or spacing

- 1. Replace gate tube
- 2. Replace printer assembly

a(6).....Print one character only and stop

- 1. Check and clean contacts under keyboard assembly
- 2. Check and clean contacts on both sides of sliding contact board
- 3. Replace unit which has defective contacts
- 4. Replace contact panel assembly

Repeats in a nonrhythmic manner

- 1. Replace printer assembly
- 2. Replace contact panel assembly

a(7).....Rotor or rotors do not step

- 1. Check and clean contacts under stepping unit
- 2. Check and clean contacts under printer assembly

CONFIDENTIAL

ORIGINAL

* See Note pg 31

DOCID: 3842901

CONFIDENTIAL

AFSAG 1236

*Test Par.
No. 5006*

Trouble and Remedy

3. Replace units which have defective contacts
4. Replace stepping unit

b(2).....Machine fails to make automatic cycle

1. Check and clean contacts under keyboard assembly
2. Check and clean contacts on both sides of sliding contact board
3. Replace unit which has defective contacts
4. Replace keyboard assembly
5. Replace sliding contact board
6. Replace contact panel assembly

b(2)(d).....No rotors step

1. Check and clean contacts under keyboard assembly
2. Check and clean contacts on both sides of contact board
3. Replace unit which has defective contacts
4. Replace stepping unit

One rotor steps

1. Replace stepping unit

b(4).....No printing or stops printing before count is reached

1. Check and clean contacts under cipher unit
2. Check and clean contacts under stepping unit
3. Check and clean contacts of all rotors and apply Lubriplate
4. Check and clean contacts of end plate assemblies
5. Replace units which have defective contacts
6. Replace cipher unit
7. Replace stepping unit

Does not print five-letter groups

1. Replace printer assembly
2. Replace keyboard assembly
3. Replace sliding contact board

b(10).....Rotors do not agree

1. Replace stepping unit
2. Replace cipher unit

b(11).....Tapes do not agree

1. Replace stepping unit
2. Replace cipher unit

b(14).....Seventy-two characters not printed

1. Retype sentence
2. Check and clean contacts under cipher unit
3. Check and clean contacts under stepping unit
4. Check and clean contacts between cipher unit and rotor stepping unit
5. Replace units which have defective contacts

CONFIDENTIAL

ORIGINAL

DIVULGUÉ EN VERTU DE LA LAI RENSEIGNEMENTS NON CLASSIFIÉS

DOCID: 3842901

~~CONFIDENTIAL~~

AFSAG 1236

*Test Par.
No. 5006**Trouble and Remedy*

6. Check, clean, and apply Lubriplate to contacts of all rotors
7. Check and clean contacts under keyboard
8. Check and clean contacts on both sides of sliding contact board

Neon glow lamp does not light when FIG key is depressed

1. Check and clean contacts under keyboard assembly
2. Check and clean contacts on both sides of sliding contact board
3. Replace unit which has defective contacts
4. Replace printer assembly

Neon glow lamp lights but machine does not print

1. Replace printer assembly

Neon glow lamp does not go out when LET key is depressed

1. Replace printer assembly

g(3) Does not decipher

1. Retype enciphered version and redecipher
2. Replace stepping unit
3. Replace cipher unit

Letters and numerals garbled

1. Replace printer assembly
2. Replace stepping unit
3. Replace cipher unit

NOTE: Operational peculiarities may be noticed when new type 2021 tubes are substituted for defective tubes. Because of slight manufacturing tolerances and varying inter-electrode reactions certain type 2021 tubes will not function properly in the critical circuits of the FIG 7. Further, some 2021 tubes will operate in one FIG 7 and will not operate in another. This fact should be considered when this type tube is replaced. If negative results are experienced when a new type 2021 tube is inserted in the unit, the operator should try several other new 2021 tubes until satisfactory operation is obtained.

~~CONFIDENTIAL~~

36

ORIGINAL

DOCID: 3842901

CONFIDENTIAL

AFSAG 1236

5400—CLEANING

5401. General Instructions.—Cleaning should be carried out as prescribed in these instructions, and should be confined to the items specified. Take care not to disturb springs or adjustments. Dirt and dust are to be removed from the exposed surfaces of the machine with the sash-brush-type cleaning brush (fig. 6(1)). Troubles frequently develop later as a result of careless cleaning. The instructions in this section have been purposely arranged to prevent such troubles, and it is therefore important that they be closely followed.

- a. *Frequency.*—Scheduled cleaning periods cannot be definitely prescribed because of varying operating conditions. The factors of dust, humidity, temperature, and the volume of traffic must be taken into consideration when setting up cleaning schedules.
- b. *Authority.*—Obtain the necessary authority for release of the equipment.

5402. Flat Head and Pressure Contacts.

- a. *Flat Head Contacts.*—Thoroughly clean the flat head contacts (fig. 4(2) and (12), and 5(14) and (15)) with a rough, dry cloth. Put a small quantity of Lubriplate #105 (fig. 6(4)) on a piece of Twiljean (fig. 6(2)) or any other lint-free cloth. Fold the cloth and rub it gently between the fingers so as to work the lubricant into the fabric. Wrap the cloth around a finger and rub the cloth lightly across the contact surfaces. The lubricant should be worked into the contacts and all excess wiped off.
- b. *Pressure Contacts.*—Clean the pressure contacts by polishing them with the canvas cleaning block assembly. Do not put Lubriplate on the pressure contacts.

Note: All flat head and pressure contacts (fig. 4 and 5) should be thoroughly cleaned whenever a component assembly is replaced.

5403. Cipher Unit Assembly.—Remove the cipher unit (see subpar. 5203a).

- a. Remove the right-hand end plate by raising its latch (fig. 5 (3)) and sliding the end plate off the rotor shaft. *Take care not to tip the assembly or the rotors will slide off the shaft.*
- b. Invert the cipher unit shell assembly, allowing the eight rotors to slide off the rotor shaft.

CAUTION: NOTE THE SEQUENCE IN WHICH THE ROTORS ARE REMOVED SO THAT THEY MAY BE REPLACED IN THE SAME ORDER (fig. 5(2) and (19), and par. 2001).

- c. Clean the ~~pressure contacts (fig. 4(14)) and the~~ flat head contacts of the left- and right-hand end plates (see par. 5402).
- d. The following procedure is to be used for cleaning each of the eight rotors:
 - (1) Clean the pressure contacts using the canvas cleaning block (fig. 6(6)).
 - (2) Clean the flat head contacts (see par. 5402).

5404. Stepping Unit Assembly.

- a. Remove the rotor stepping unit (see subpar. 5204a).
- b. Clean the contacts of the two reentry blocks (fig. 4(17)). Clean the stepping unit contact block (fig. 4(18)) with the canvas cleaning block.

5405. Printer Assembly.—Remove the printer assembly (see par. 5205).

- a. Clean the print magnet assembly (fig. 2(7)) using the small sashbrush-type cleaning brush (fig. 6(12)). *Take care not to bend the reeds.*

CONFIDENTIAL

37

ORIGINAL

DOCID: 3842901

~~CONFIDENTIAL~~

AFSAG 1236

- b. Clean the pressure contacts on the under side of the printer assembly (fig. 4(10)) using the canvas cleaning block.
- c. Remove the inked ribbon (see subpar. 5005e). Clean the figured wheel (fig. 1(9)) with the toothbrush-type cleaning brush (fig. 6(11)) saturated with cleaning solvent, if available. The characters on the figured wheel can be reached through the slot at the top of the ribbon track. Clean the characters thoroughly. Replace the ribbon.

5406. Keyboard Assembly.—Remove the keyboard assembly (see par. 5202). Clean all flat head contacts (see par. 5402).

5407. Contact Panel Assembly.

- a. Clean the top surface of the contact panel assembly with the sashbrush-type cleaning brush, paying particular attention to the small spaces between adjacent pressure contacts.
- b. Clean the pressure contacts (fig. 5(8) and (10)) with the canvas cleaning block.
- c. Clean flat head contacts (fig. 5(14) and (15)) as outlined in paragraph 5402.
- d. Clean the canopy of the lamp socket assembly with a piece of dry, lint-free cloth.

Note: For reassembly instructions, see section 5200.

~~CONFIDENTIAL~~

DIVULGUÉ EN VERTU DE LA LAI RENSEIGNEMENTS NON CLASSIFIÉS

DOCID: 3842901

CONFIDENTIAL

AFSAG 1236

5500—REPLACEMENT ASSEMBLIES AND TOOLS

5501. Replacement Assemblies.—The assemblies listed in the following table are to be requisitioned through normal Service channels.

| <i>Stock Number</i> | <i>Assembly</i> |
|---------------------|---|
| CE-11111 | Carrying Case Assembly |
| CE-11371 | Keyboard Assembly |
| CE-11566 | Printer Assembly |
| CE-11691 | Typewriter Ribbon |
| CE 11693 | Paper Tape |
| CE-11811 | Contact Board and Guide Rail Assembly |
| CE-11941 | Contact Panel Assembly |
| CE-14504 | Base Assembly |
| CE-14516 | Fuse (Cipher Machine) |
| CE 14517 | Neon Glow Lamp |
| CE-14563 | AC Power Converter Assembly |
| CE-14569 | Cipher Unit Assembly—AFSAM 207 (Order by short title as registered cryptographic equipment) |
| CE-14570 | Stepping Unit Assembly—AFSAM 107 (Order by short title as registered cryptographic equipment) |
| CE-14592 | Fuse (Power Converter) |
| CE-14671 | Accessories Case Cover |
| CE-14676 | Accessories Case |
| JAN2D21 | Tube Type 2D21 |
| JAN12AX7 | Tube Type 12AX7 |

5502. Recommended Tools (fig. 6).—The following list of tools are recommended for use in the maintenance of AFSAM 7 as outlined in this document.

| <i>Stock Number</i> | <i>Recommended Tools</i> |
|---------------------|---|
| CE-855 | Twiljean Cloth |
| CE-871 | Toothbrush-type Cleaning Brush |
| CE-872 | Sashbrush-type Cleaning Brush |
| CE 10175 | $\frac{1}{8}$ -inch Allen Key |
| CE-14685 | Small Sashbrush-type Cleaning Brush |
| CE-14687 | $\frac{3}{32}$ -inch T-handle Allen Key |
| CE-14688 | $\frac{1}{16}$ -inch T-handle Allen Key |
| 100973 | Cleaning Block Assembly |
| 100978 | Web Strap |
| 108805 | Lubriplate #105 |
| CE-14795 | $\frac{3}{32}$ -inch Plastic Handle Allen Key |
| CE-14796 | $\frac{1}{8}$ -inch Plastic Handle Allen Key |

CONFIDENTIAL

39

ORIGINAL

DOCID: 3842901

~~CONFIDENTIAL~~

AFSAG 1236

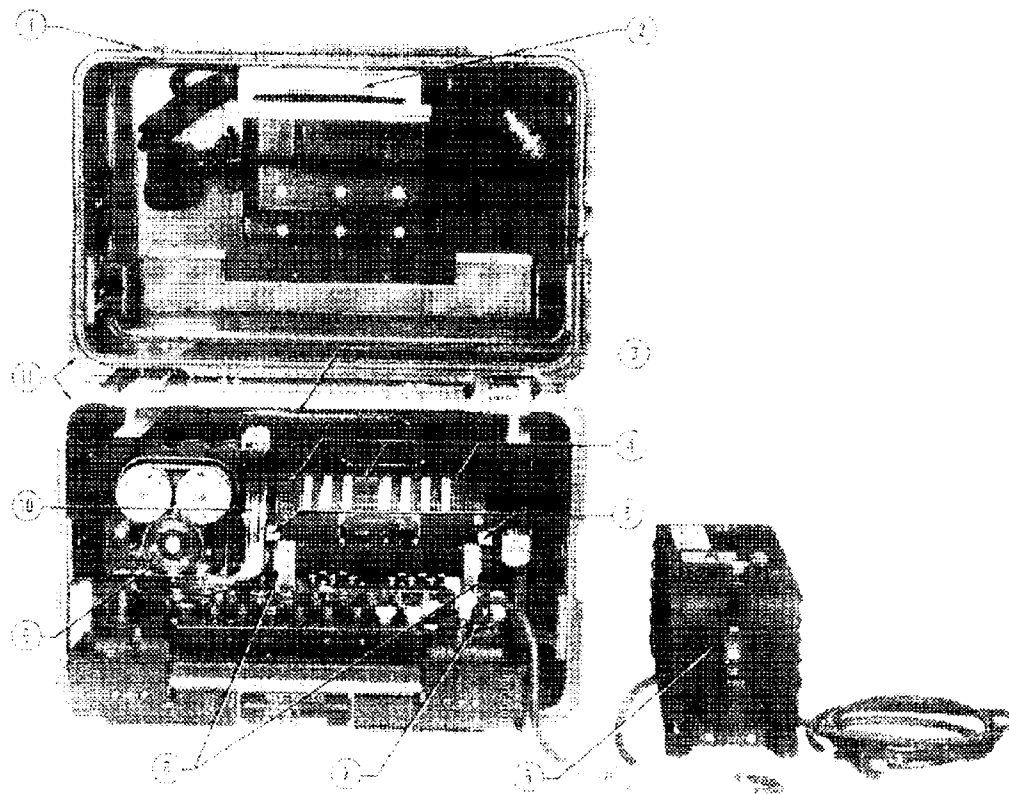

Figure 1

- 1. Cover Bolting Latch
- 2. Copy Holder
- 3. Spare Paper Tape Holder
- 4. Cipher Unit Assembly Index Marks
- 5. Cipher Unit Latch Assemblies
- 6. AC Power Converter Assembly
- 7. Power Cable and Cover Plate Assembly
- 8. Stepping Unit Assembly Captive Thumb Screws
- 9. Figured Wheel
- 10. Paper Tape Container
- 11. Carrying Case

~~CONFIDENTIAL~~

ORIGINAL

DOCID: 3842901

~~CONFIDENTIAL~~

AFSAG 1236

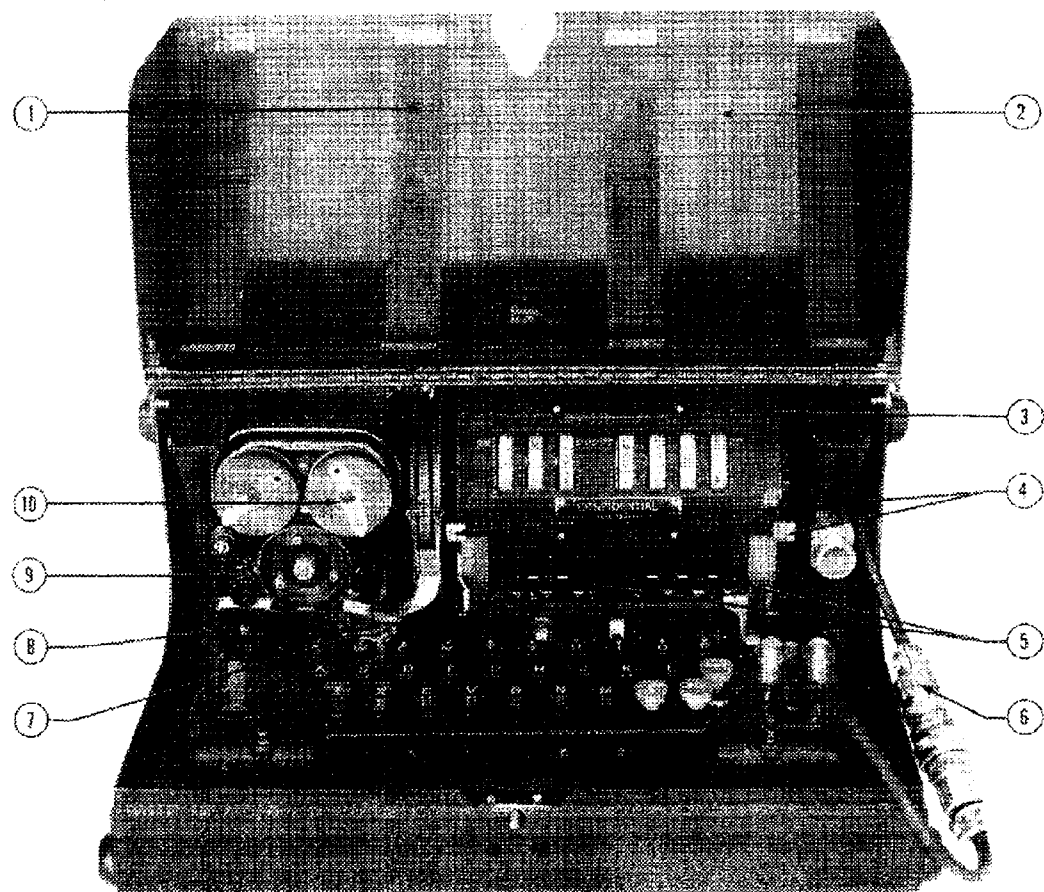

Figure 2

- | | |
|---------------------------------|--------------------------------|
| 1. Copy Holder | 6. Power Cable |
| 2. Office Case Cover | 7. Print Magnet Assembly |
| 3. Cipher Unit Assembly | 8. Paper Tape Feed Roll |
| 4. Cipher Unit Latch Assemblies | 9. Feed Roll Follower Assembly |
| 5. Set Keys | 10. Ribbon Spools |

~~CONFIDENTIAL~~

ORIGINAL

~~CONFIDENTIAL~~

AFSAG 1236

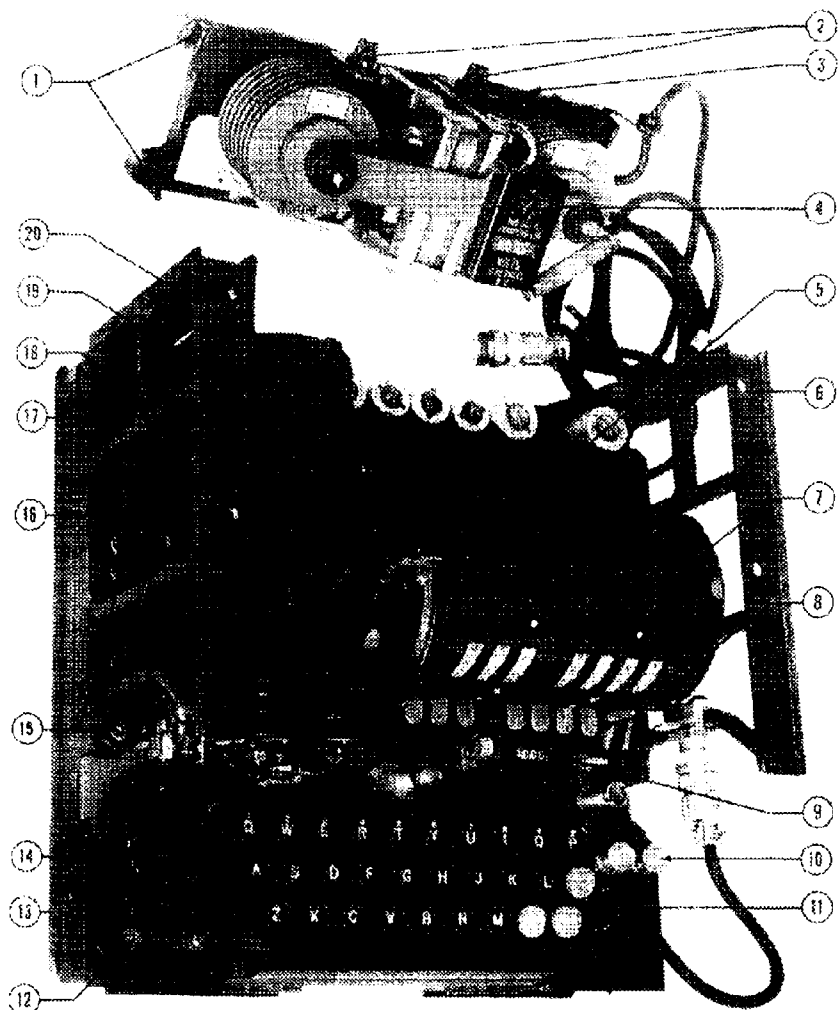

Figure 3

- | | |
|---|--|
| 1. AC Power Converter Assembly Captive Thumb Screws | 10. Fuse Holder Assemblies |
| 2. AC Power Converter Assembly Fuse Holder Assemblies | 11. Power Cable and Cover Plate Assembly |
| 3. AC Power Converter Assembly | 12. Keyboard Assembly |
| 4. AC Power Converter Selector Switch Assembly | 13. Selector Handle |
| 5. Stepping Unit Assembly | 14. Keyboard Assembly Captive Screws |
| 6. Right-hand Bracket Assembly | 15. Left-hand Bracket Captive Screws |
| 7. Cipher Unit Assembly | 16. Printer Assembly Captive Screws |
| 8. Stepping Unit Assembly Captive Thumb Screw | 17. Clutch Trip Magnet Assembly |
| 9. Counter Assembly | 18. Swivel Pin Assembly |
| | 19. Printer Assembly |
| | 20. Left-hand Support Bracket |

~~CONFIDENTIAL~~

ORIGINAL

DOCID: 3842901

~~CONFIDENTIAL~~

AFSAG 1236

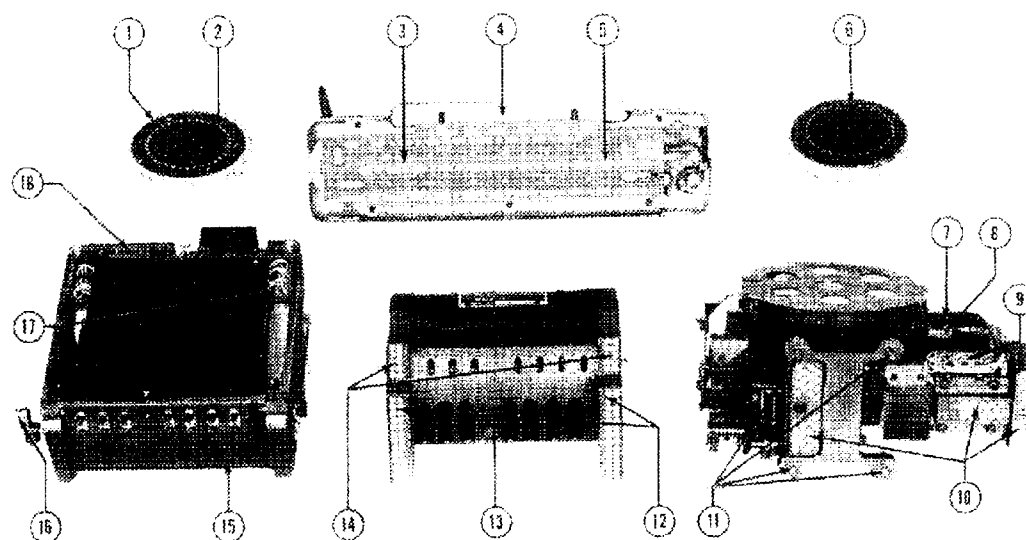

Figure 4

- | | |
|--|---|
| 1. Rotor Assembly | 10. Printer Assembly Pressure Contacts |
| 2. Rotor Flat Head Contacts | 11. Printer Assembly Captive Screw |
| 3. Sliding Contact Board and Guide Rail Assembly | 12. Cipher Unit Assembly Flat Head Contacts |
| 4. Keyboard Assembly | 13. Cipher Unit Assembly Shell |
| 5. Sliding Contact Board Flat Head Contacts | 14. Cipher Unit Assembly Pressure Contacts |
| 6. Rotor Pressure Contacts | 15. Stepping Unit Assembly |
| 7. Printer Assembly | 16. Rotor Stepping Crank |
| 8. Drive Link Assembly | 17. Reentry Circuit Contact Blocks |
| 9. Timing Cam Switches | 18. Stepping Unit Assembly Contact Block |

~~CONFIDENTIAL~~

ORIGINAL

~~CONFIDENTIAL~~

AFSAG 1236

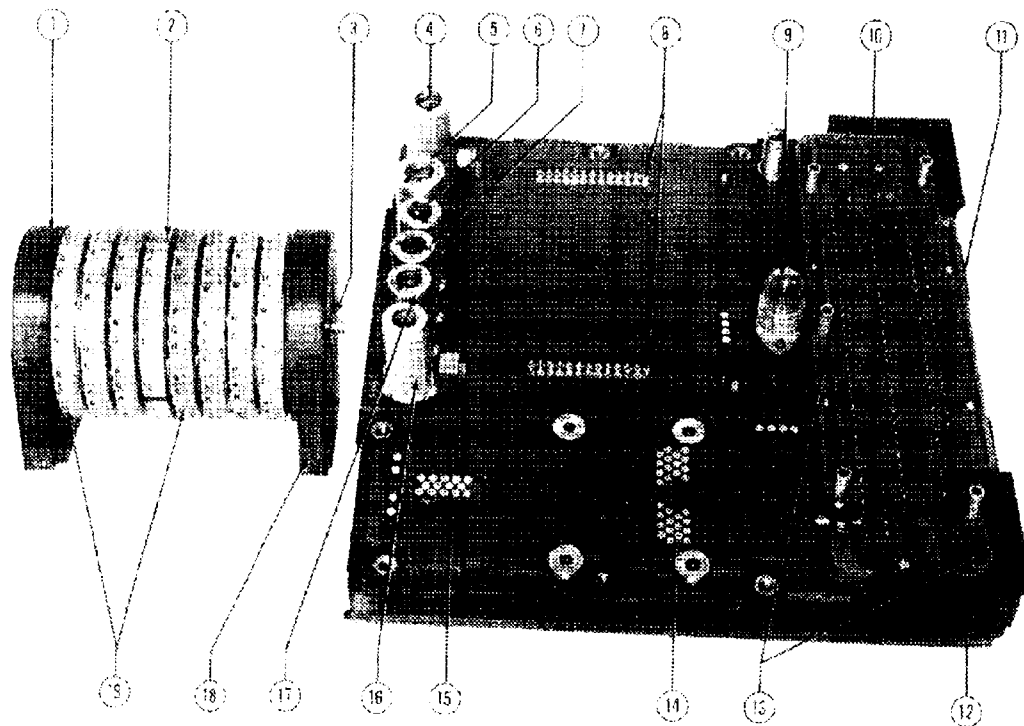

Figure 5

- | | |
|---|--|
| <ul style="list-style-type: none"> 1. Left-hand End Plate Assembly 2. Stationary Rotor 3. Right-hand End Plate Latch 4. Spare 12AX7 Tube with Shield 5. Gate Tube (12AX7) with Shield 6. Shift Tube (2D21) with Shield 7. Sharpener Tube (2D21) with Shield 8. Pressure Contacts (Cipher Unit Assembly Area) 9. Neon Glow Lamp 10. Pressure Contacts (Keyboard Assembly Area) | <ul style="list-style-type: none"> 11. Contact Panel Assembly 12. Base Assembly 13. Contact Panel Assembly Mounting Screws 14. Flat Head Contacts (Pulse Generator Area) 15. Flat Head Contacts (Timing Unit Area) 16. Spare 2D21 Tube with Shield 17. Print Tube (2D21) with Shield 18. Right-hand End Plate Assembly 19. Movable Rotors |
|---|--|

~~CONFIDENTIAL~~

ORIGINAL

DOCID: 3842901

~~CONFIDENTIAL~~

AFSAG 1236

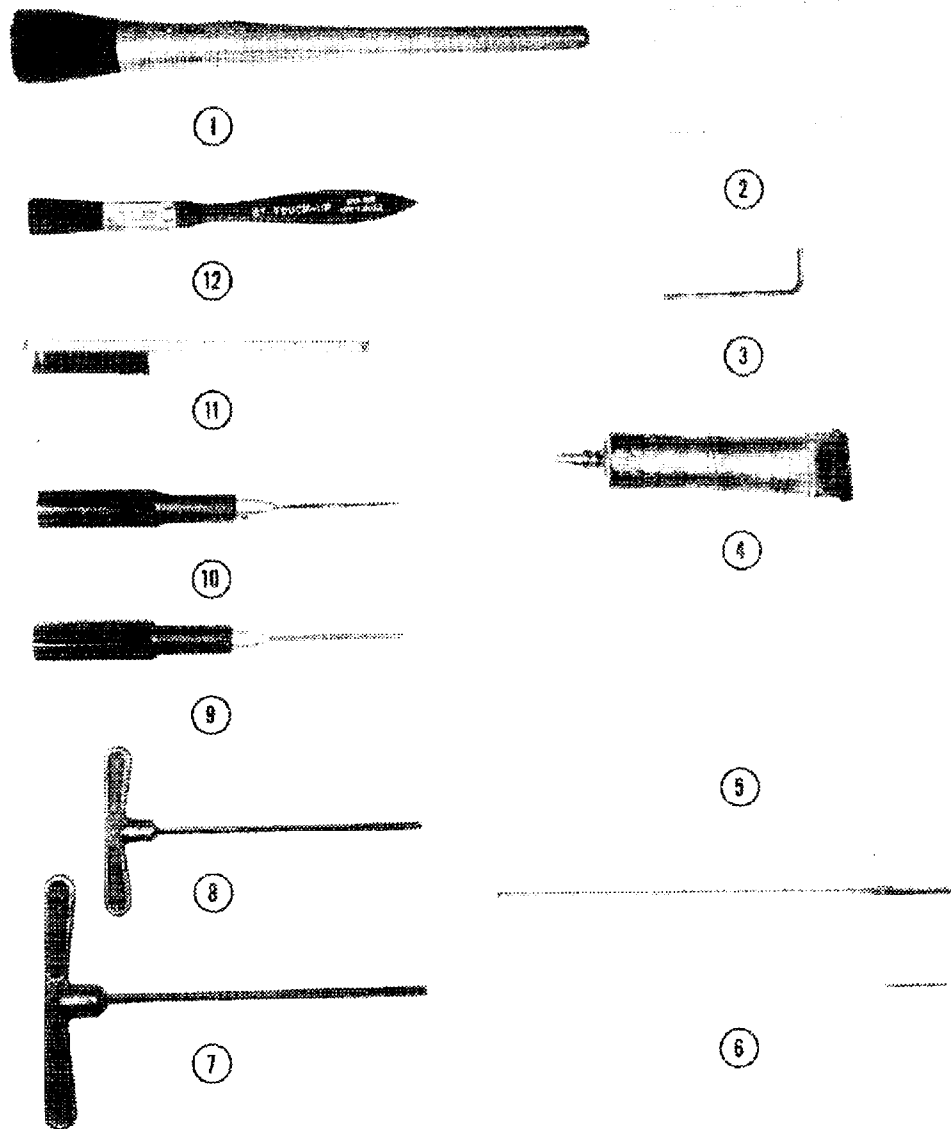

Figure 6

- 1. Sashbrush-type Cleaning Brush
- 2. Twilljean Cloth
- 3. $\frac{1}{16}$ -inch Allen Key
- 4. Lubriplate #195
- 5. Web Strap
- 6. Cleaning Block Assembly

- 7. $\frac{3}{16}$ -inch T-handle Allen Key
- 8. $\frac{5}{16}$ -inch T-handle Allen Key
- 9. $\frac{1}{4}$ -inch Plastic Handle Allen Key
- 10. $\frac{3}{8}$ -inch Plastic Handle Allen Key
- 11. Toothbrush-type Cleaning Brush
- 12. Small Sashbrush-type Cleaning Brush

~~CONFIDENTIAL~~

ORIGINAL
(Reverse Blank)

DIVULGUÉ EN VERTU DE LA LAI RENSEIGNEMENTS NON CLASSIFIÉS

DOCID: 3842901

DIVULGUÉ EN VERTU DE LA LAI RENSEIGNEMENTS NON
CLASSIFIÉS

DOCID: 3842901