

# DATA SHEET



## **PCF8570**

**256 × 8-bit static low-voltage RAM  
with I<sup>2</sup>C-bus interface**

Product specification  
Supersedes data of 1997 Sep 02  
File under Integrated Circuits, IC12

1999 Jan 06

---

**256 × 8-bit static low-voltage RAM with  
I<sup>2</sup>C-bus interface**

---

**PCF8570****CONTENTS**

1	FEATURES
2	APPLICATIONS
3	GENERAL DESCRIPTION
4	QUICK REFERENCE DATA
5	ORDERING INFORMATION
6	BLOCK DIAGRAM
7	PINNING
8	CHARACTERISTICS OF THE I <sup>2</sup> C-BUS
8.1	Bit transfer
8.2	Start and stop conditions
8.3	System configuration
8.4	Acknowledge
8.5	I <sup>2</sup> C-bus protocol
9	LIMITING VALUES
10	HANDLING
11	DC CHARACTERISTICS
12	AC CHARACTERISTICS
13	APPLICATION INFORMATION
13.1	Application example
13.2	Slave address
13.3	Power-saving mode
14	PACKAGE OUTLINES
15	SOLDERING
15.1	Introduction
15.2	Through-hole mount packages
15.2.1	Soldering by dipping or by solder wave
15.2.2	Manual soldering
15.3	Surface mount packages
15.3.1	Reflow soldering
15.3.2	Wave soldering
15.3.3	Manual soldering
15.4	Suitability of IC packages for wave, reflow and dipping soldering methods
16	DEFINITIONS
17	LIFE SUPPORT APPLICATIONS
18	PURCHASE OF PHILIPS I <sup>2</sup> C COMPONENTS

## 256 × 8-bit static low-voltage RAM with I<sup>2</sup>C-bus interface

PCF8570

### 1 FEATURES

- Operating supply voltage 2.5 to 6.0 V
- Low data retention voltage; minimum 1.0 V
- Low standby current; maximum 15  $\mu$ A
- Power-saving mode; typical 50 nA
- Serial input/output bus (I<sup>2</sup>C-bus)
- Address by 3 hardware address pins
- Automatic word address incrementing
- Available in DIP8 and SO8 packages.

### 2 APPLICATIONS

- Telephony:
  - RAM expansion for stored numbers in repertory dialling (e.g. PCD33xxA applications)
- General purpose RAM for applications requiring extremely low current and low-voltage RAM retention, such as battery or capacitor-backed.
- Radio, television and video cassette recorder:
  - channel presets
- General purpose:
  - RAM expansion for the microcontroller families PCD33xxA, PCF84CxxxA, P80CLxxx and most other microcontrollers.



### 3 GENERAL DESCRIPTION

The PCF8570 is a low power static CMOS RAM, organized as 256 words by 8-bits.

Addresses and data are transferred serially via a two-line bidirectional bus (I<sup>2</sup>C-bus). The built-in word address register is incremented automatically after each written or read data byte. Three address pins, A0, A1 and A2 are used to define the hardware address, allowing the use of up to 8 devices connected to the bus without additional hardware.

### 4 QUICK REFERENCE DATA

SYMBOL	PARAMETER	CONDITIONS	MIN.	MAX.	UNIT
V <sub>DD</sub>	supply voltage		2.5	6.0	
I <sub>DD</sub>	supply current (standby)	f <sub>SCL</sub> = 0 Hz	–	15	$\mu$ A
I <sub>DDR</sub>	supply current (power-saving mode)	T <sub>amb</sub> = 25 °C	–	400	nA
T <sub>amb</sub>	operating ambient temperature		–40	+85	°C
T <sub>stg</sub>	storage temperature		–65	+150	°C

### 5 ORDERING INFORMATION

TYPE NUMBER	PACKAGE		
	NAME	DESCRIPTION	VERSION
PCF8570P	DIP8	plastic dual in-line package; 8 leads (300 mil)	SOT97-1
PCF8570T	SO8	plastic small outline package; 8 leads; body width 7.5 mm	SOT176-1

256 × 8-bit static low-voltage RAM with I<sup>2</sup>C-bus interface

PCF8570

6 BLOCK DIAGRAM

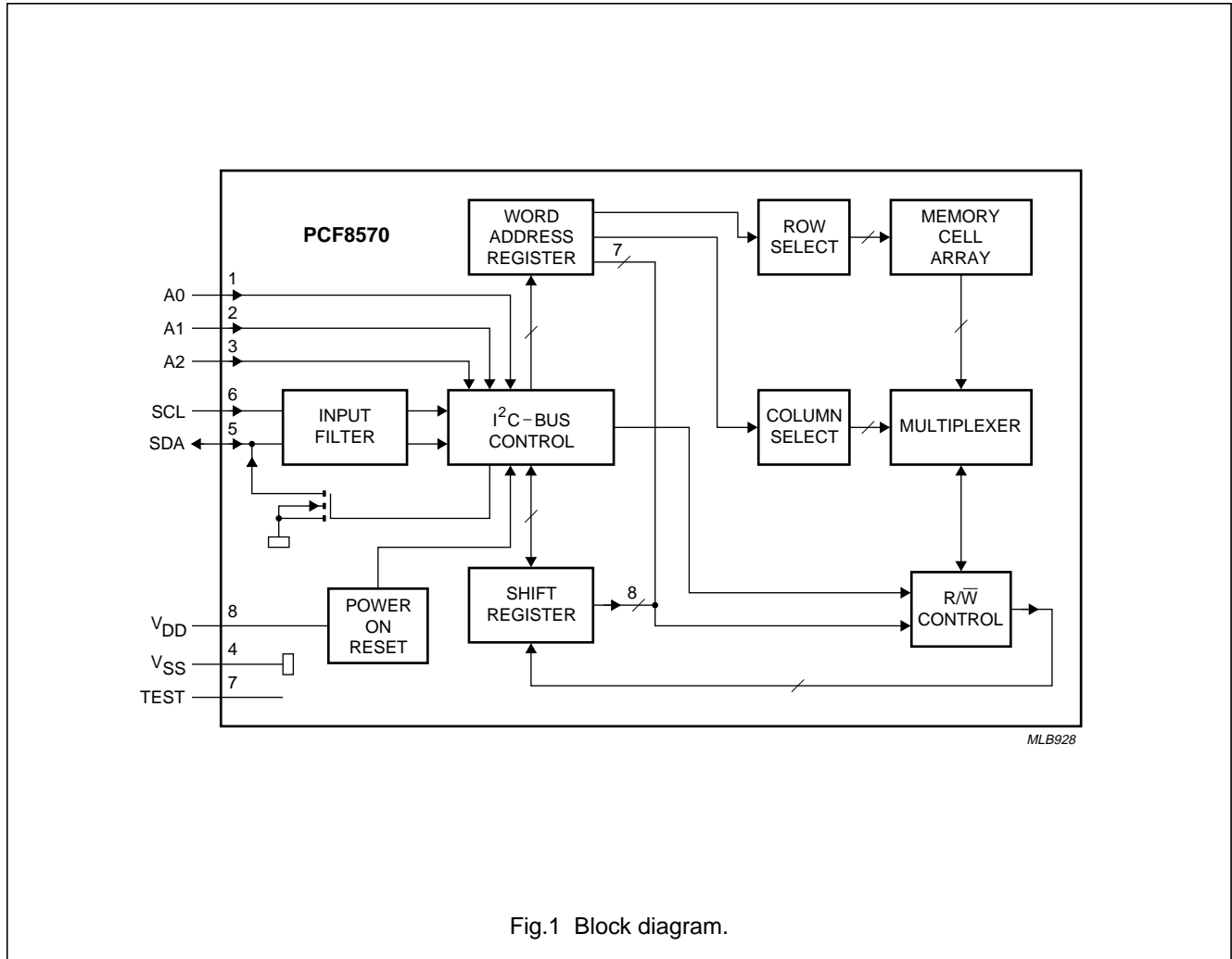

Fig.1 Block diagram.

7 PINNING

SYMBOL	PIN	DESCRIPTION
A0	1	hardware address input 0
A1	2	hardware address input 1
A2	3	hardware address input 2
V <sub>SS</sub>	4	negative supply
SDA	5	serial data input/output
SCL	6	serial clock input
TEST	7	Input for power-saving mode (see section "Power-saving mode"). Also used as a test output during manufacture. TEST should be tied to V <sub>SS</sub> during normal operation.
V <sub>DD</sub>	8	positive supply

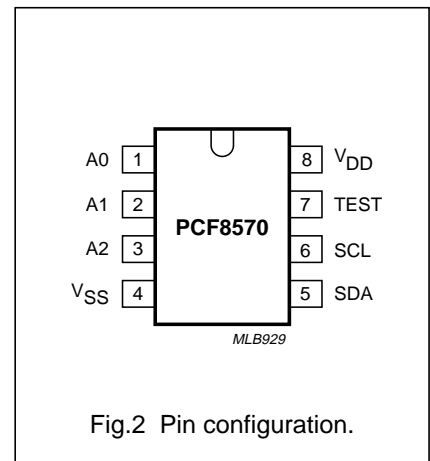

Fig.2 Pin configuration.

# 256 × 8-bit static low-voltage RAM with I<sup>2</sup>C-bus interface

PCF8570

## 8 CHARACTERISTICS OF THE I<sup>2</sup>C-BUS

The I<sup>2</sup>C-bus is for bidirectional, two-line communication between different ICs or modules. The two lines are a serial data line (SDA) and a serial clock line (SCL). Both lines must be connected to a positive supply via a pull-up resistor. Data transfer may be initiated only when the bus is not busy.

### 8.1 Bit transfer

One data bit is transferred during each clock pulse. The data on the SDA line must remain stable during the HIGH period of the clock pulse as changes in the data line at this time will be interpreted as a control signal.

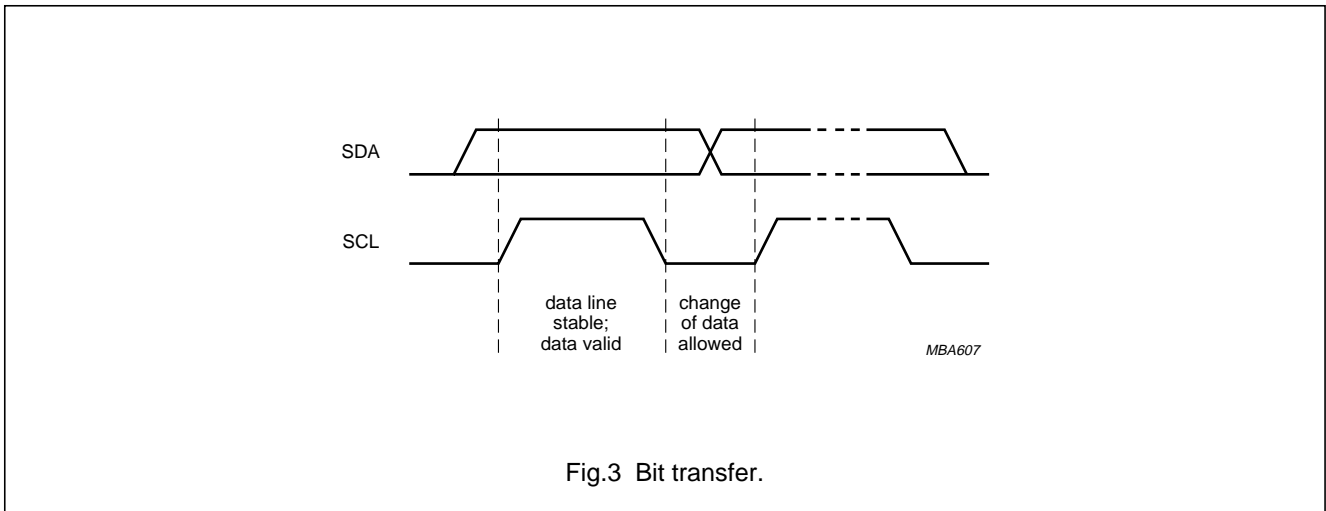

### 8.2 Start and stop conditions

Both data and clock lines remain HIGH when the bus is not busy. A HIGH-to-LOW transition of the data line, while the clock is HIGH is defined as the start condition (S). A LOW-to-HIGH transition of the data line while the clock is HIGH is defined as the stop condition (P).

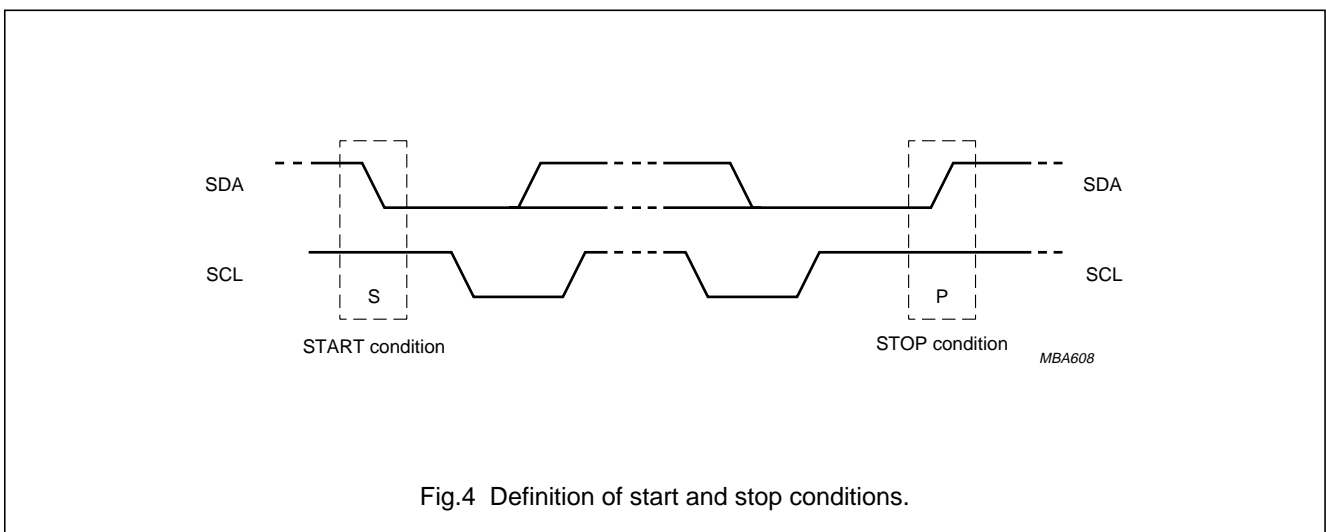

# 256 × 8-bit static low-voltage RAM with I<sup>2</sup>C-bus interface

PCF8570

### 8.3 System configuration

A device generating a message is a 'transmitter', a device receiving a message is the 'receiver'. The device that controls the message is the 'master' and the devices which are controlled by the master are the 'slaves'.

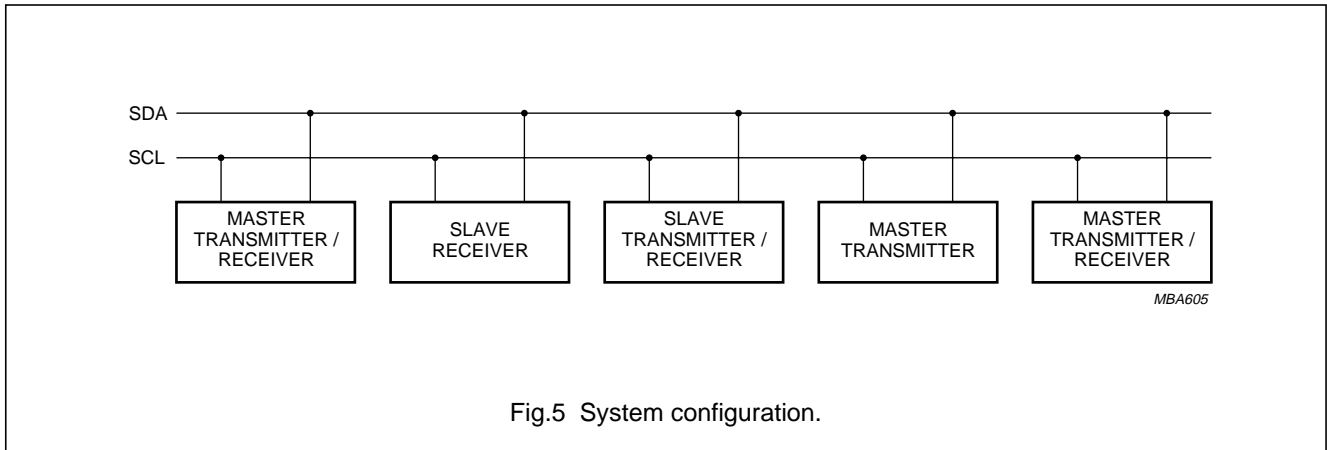

Fig.5 System configuration.

### 8.4 Acknowledge

The number of data bytes transferred between the start and stop conditions from transmitter to receiver is unlimited. Each byte of eight bits is followed by an acknowledge bit. The acknowledge bit is a HIGH level signal put on the bus by the transmitter during which time the master generates an extra acknowledge related clock pulse. A slave receiver which is addressed must generate an acknowledge after the reception of each byte. Also a master receiver must generate an acknowledge after the reception of each byte that has been clocked out of the slave transmitter.

The device that acknowledges must pull down the SDA line during the acknowledge clock pulse, so that the SDA line is stable LOW during the HIGH period of the acknowledge related clock pulse (set-up and hold times must be taken into consideration). A master receiver must signal an end of data to the transmitter by not generating an acknowledge on the last byte that has been clocked out of the slave. In this event the transmitter must leave the data line HIGH to enable the master to generate a stop condition.

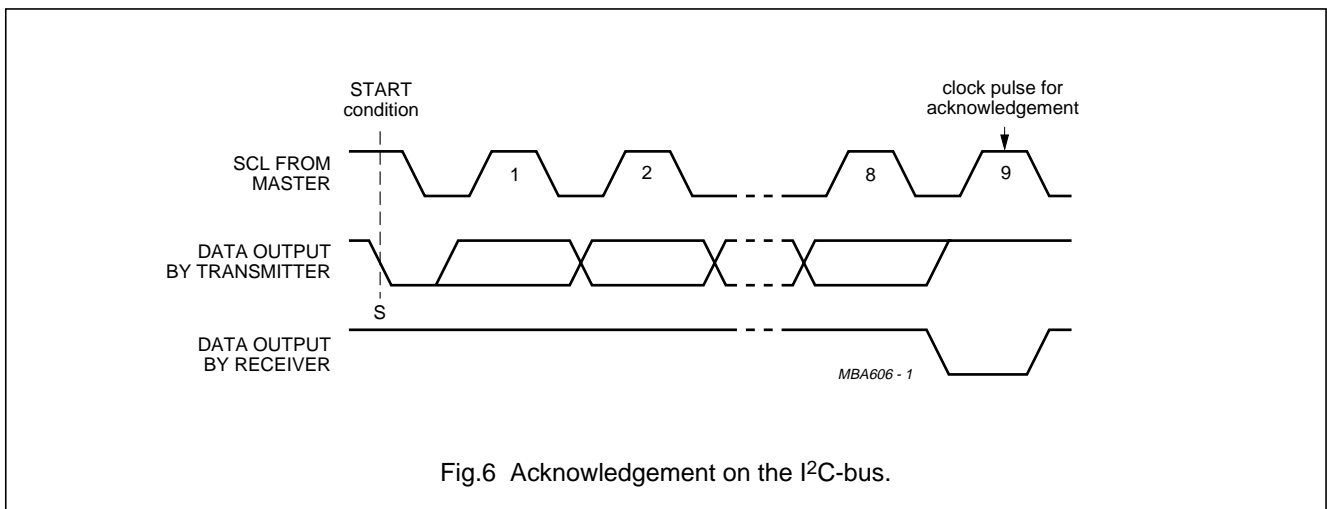

Fig.6 Acknowledgement on the I<sup>2</sup>C-bus.

# 256 × 8-bit static low-voltage RAM with I<sup>2</sup>C-bus interface

PCF8570

## 8.5 I<sup>2</sup>C-bus protocol

Before any data is transmitted on the I<sup>2</sup>C-bus, the device which should respond is addressed first. The addressing is always carried out with the first byte transmitted after the start procedure. The I<sup>2</sup>C-bus configuration for the different PCF8570 WRITE and READ cycles is shown in Figs 7, 8 and 9.

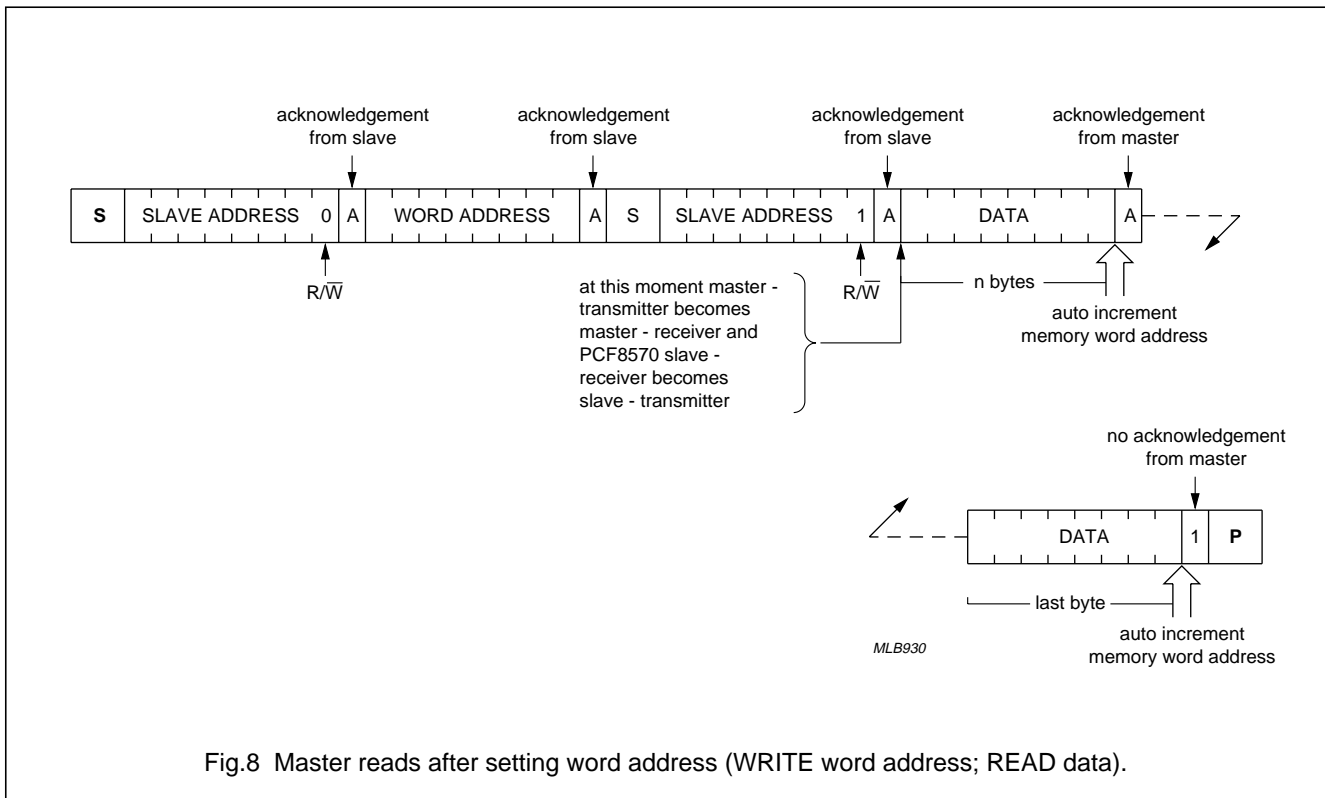
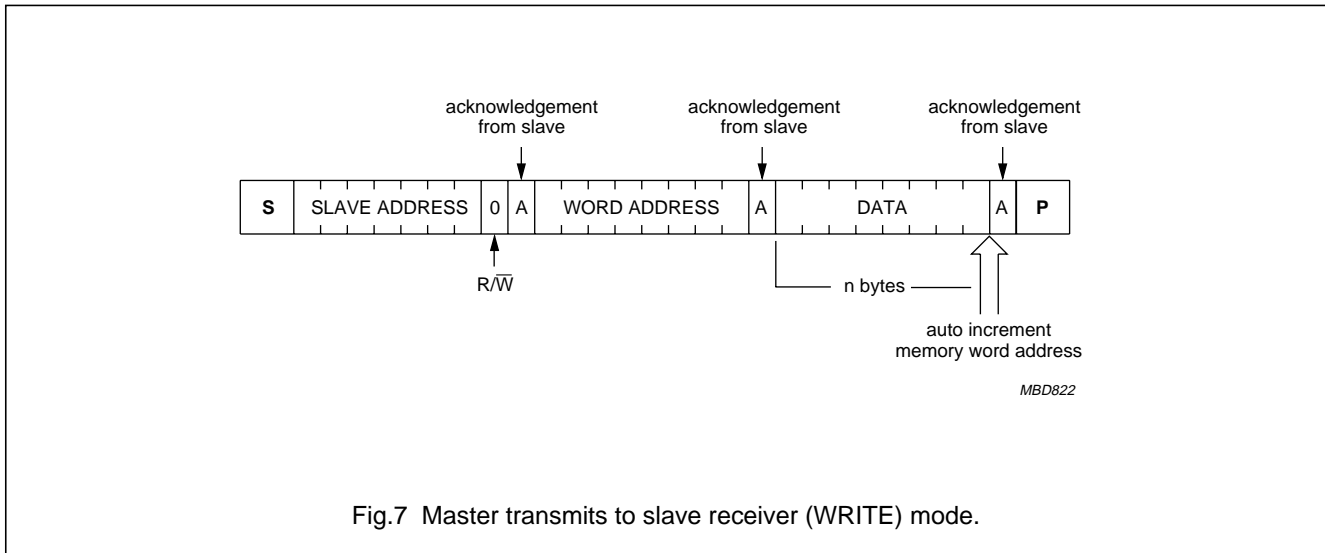

256 × 8-bit static low-voltage RAM with I<sup>2</sup>C-bus interface

PCF8570

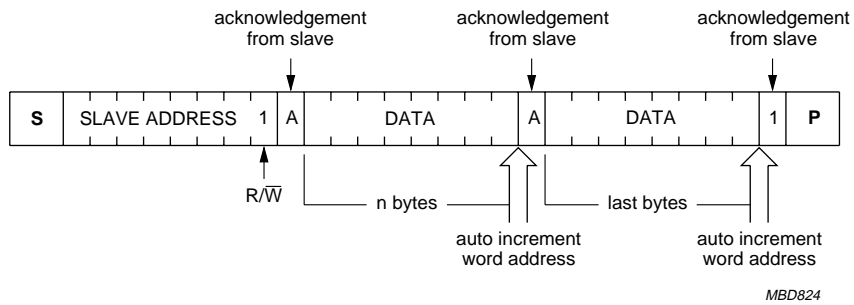

Fig.9 Master reads slave immediately after first byte (READ mode).

9 LIMITING VALUES

In accordance with the Absolute Maximum Rating System (IEC 134).

SYMBOL	PARAMETER	MIN.	MAX.	UNIT
V <sub>DD</sub>	supply voltage (pin 8)	-0.8	+8.0	V
V <sub>I</sub>	input voltage (any input)	-0.8	V <sub>DD</sub> + 0.8	V
I <sub>I</sub>	DC input current	-	±10	mA
I <sub>O</sub>	DC output current	-	±10	mA
I <sub>DD</sub>	positive supply current	-	±50	mA
I <sub>SS</sub>	negative supply current	-	±50	mA
P <sub>tot</sub>	total power dissipation per package	-	300	mW
P <sub>O</sub>	power dissipation per output	-	50	mW
T <sub>amb</sub>	operating ambient temperature	-40	+85	°C
T <sub>stg</sub>	storage temperature	-65	+150	°C

10 HANDLING

Inputs and outputs are protected against electrostatic discharge in normal handling. However, to be totally safe, it is desirable to take precautions appropriate to handling MOS devices. Advice can be found in Data Handbook IC12 under "Handling MOS Devices".



# 256 × 8-bit static low-voltage RAM with I<sup>2</sup>C-bus interface

PCF8570

## 11 DC CHARACTERISTICS

$V_{DD} = 2.5$  to  $6.0$  V;  $V_{SS} = 0$  V;  $T_{amb} = -40$  to  $+85$  °C; unless otherwise specified.

SYMBOL	PARAMETER	CONDITIONS	MIN.	TYP.	MAX.	UNIT
<b>Supply</b>						
$V_{DD}$	supply voltage		2.5	–	6.0	V
$I_{DD}$	supply current standby mode	$V_I = V_{DD}$ or $V_{SS}$ ; $f_{SCL} = 0$ Hz; $T_{amb} = -25$ to $+70$ °C	–	–	5	μA
	operating mode	$V_I = V_{DD}$ or $V_{SS}$ ; $f_{SCL} = 100$ Hz	–	–	200	μA
$V_{POR}$	Power-on reset voltage	note 1	1.5	1.9	2.3	V
<b>Inputs, input/output SDA</b>						
$V_{IL}$	LOW level input voltage	note 2	–0.8	–	$0.3V_{DD}$	V
$V_{IH}$	HIGH level input voltage	note 2	$0.7V_{DD}$	–	$V_{DD} + 0.8$	V
$I_{OL}$	LOW level output current	$V_{OL} = 0.4$ V	3	–	–	mA
$I_{LI}$	input leakage current	$V_I = V_{DD}$ or $V_{SS}$	–1	–	+1	μA
<b>Inputs A0, A1, A2 and TEST</b>						
$I_{LI}$	input leakage current	$V_I = V_{DD}$ or $V_{SS}$	–250	–	+250	nA
<b>Inputs SCL and SDA</b>						
$C_i$	input capacitance	$V_I = V_{SS}$	–	–	7	pF
<b>Low <math>V_{DD}</math> data retention</b>						
$V_{DDR}$	supply voltage for data retention		1	–	6	V
$I_{DDR}$	supply current	$V_{DDR} = 1$ V	–	–	5	μA
		$V_{DDR} = 1$ V; $T_{amb} = -25$ to $+70$ °C	–	–	2	μA
<b>Power-saving mode (see Figs 13 and 14)</b>						
$I_{DDR}$	supply current	TEST = $V_{DD}$ ; $T_{amb} = 25$ °C	–	50	400	nA
$t_{HD2}$	recovery time		–	50	–	μs

### Notes

- The Power-on reset circuit resets the I<sup>2</sup>C-bus logic when  $V_{DD} < V_{POR}$ . The status of the device after a Power-on reset condition can be tested by sending the slave address and testing the acknowledge bit.
- If the input voltages are a diode voltage above or below the supply voltage  $V_{DD}$  or  $V_{SS}$  an input current will flow; this current must not exceed  $\pm 0.5$  mA.

256 × 8-bit static low-voltage RAM with I<sup>2</sup>C-bus interface

PCF8570

12 AC CHARACTERISTICS

All timing values are valid within the operating supply voltage and ambient temperature range and reference to V<sub>IL</sub> and V<sub>IH</sub> with an input voltage swing of V<sub>SS</sub> to V<sub>DD</sub>.

SYMBOL	PARAMETER	MIN.	TYP.	MAX.	UNIT
<b>I<sup>2</sup>C-bus timing</b> (see Fig.10; note 1)					
f <sub>SCL</sub>	SCL clock frequency	–	–	100	kHz
t <sub>SP</sub>	tolerable spike width on bus	–	–	100	ns
t <sub>BUF</sub>	bus free time	4.7	–	–	μs
t <sub>SU;STA</sub>	START condition set-up time	4.7	–	–	μs
t <sub>HD;STA</sub>	START condition hold time	4.0	–	–	μs
t <sub>LOW</sub>	SCL LOW time	4.7	–	–	μs
t <sub>HIGH</sub>	SCL HIGH time	4.0	–	–	μs
t <sub>r</sub>	SCL and SDA rise time	–	–	1.0	μs
t <sub>f</sub>	SCL and SDA fall time	–	–	0.3	μs
t <sub>SU;DAT</sub>	data set-up time	250	–	–	ns
t <sub>HD;DAT</sub>	data hold time	0	–	–	ns
t <sub>VD;DAT</sub>	SCL LOW-to-data out valid	–	–	3.4	μs
t <sub>SU;STO</sub>	STOP condition set-up time	4.0	–	–	μs

Note

1. A detailed description of the I<sup>2</sup>C-bus specification, with applications, is given in brochure “The I<sup>2</sup>C-bus and how to use it”. This brochure may be ordered using the code 9398 393 40011.

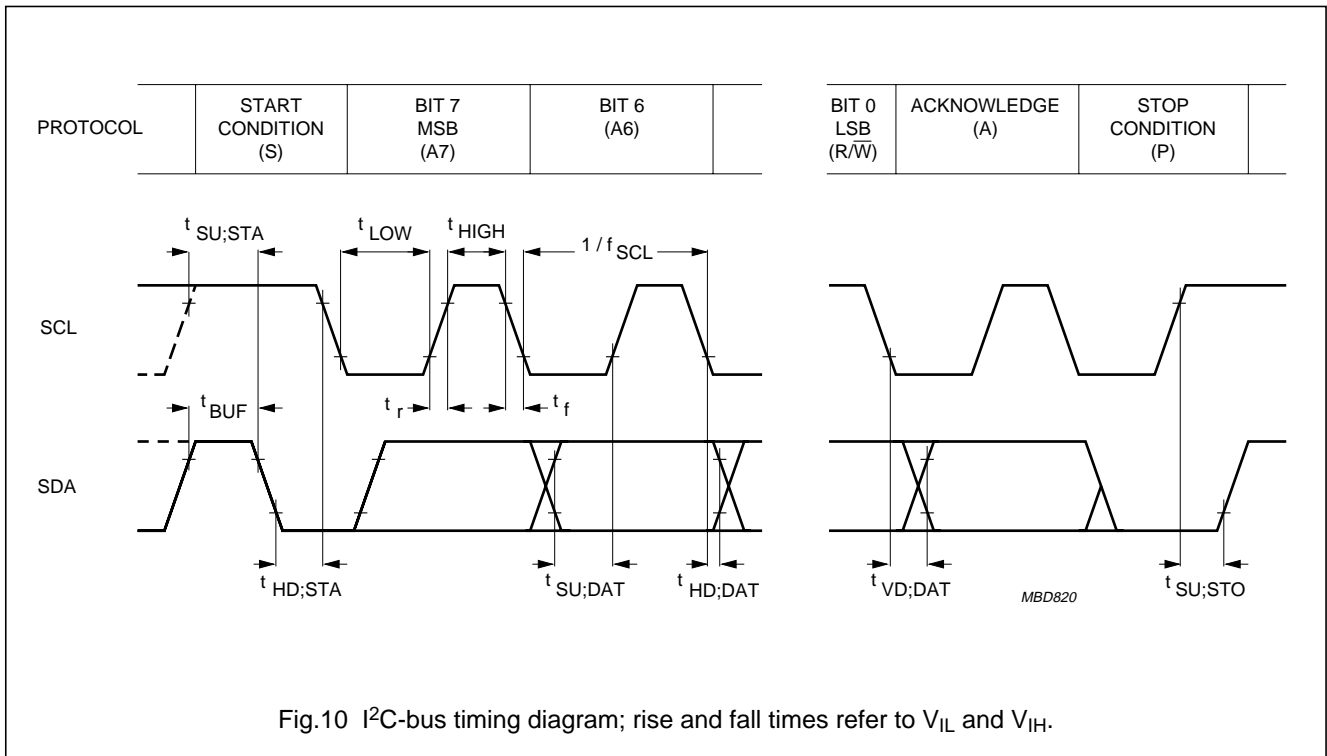

# 256 × 8-bit static low-voltage RAM with I<sup>2</sup>C-bus interface

## PCF8570

### 13 APPLICATION INFORMATION

#### 13.1 Application example

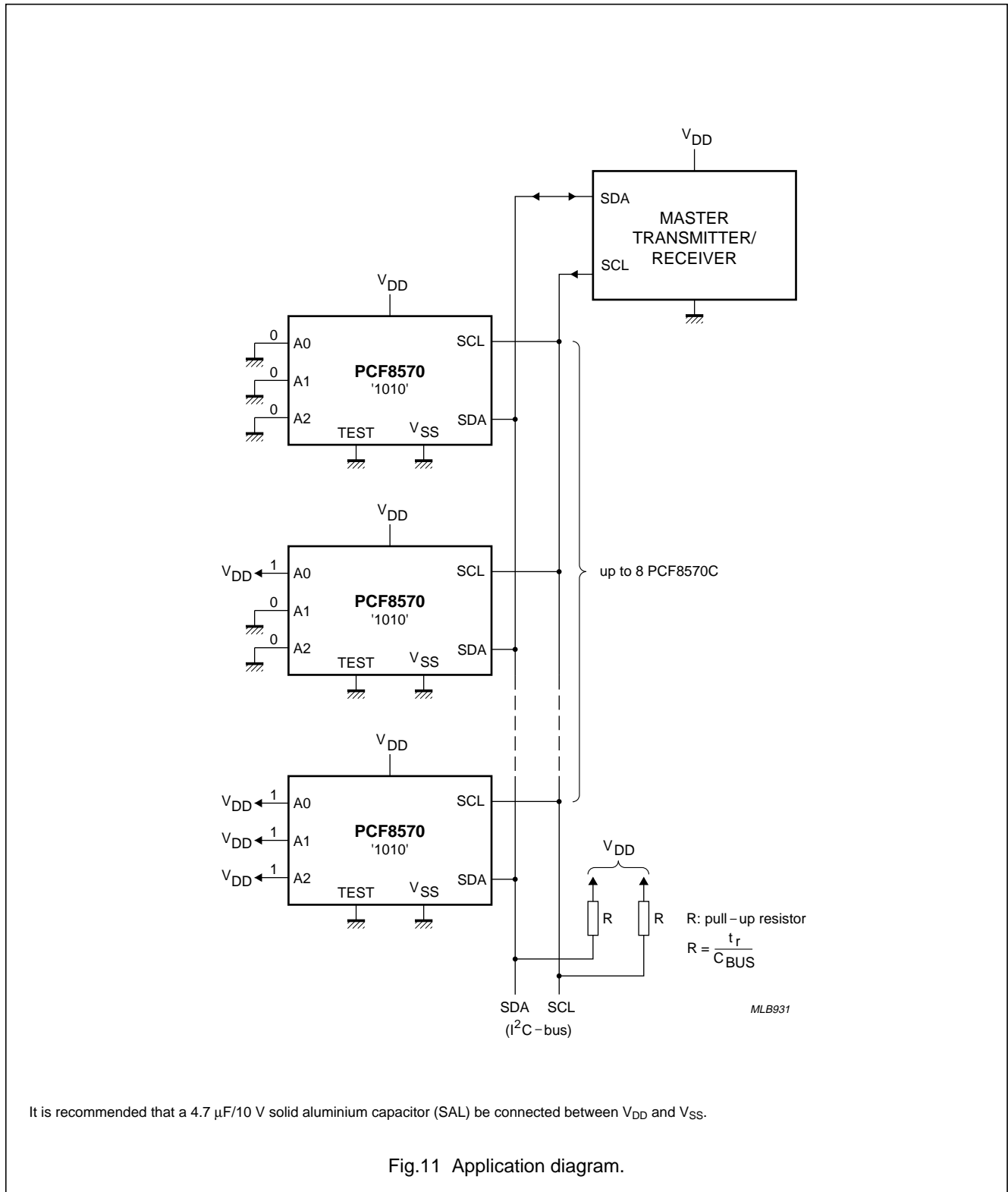

256 × 8-bit static low-voltage RAM with I<sup>2</sup>C-bus interface

PCF8570

13.2 Slave address

The PCF8570 has a fixed combination 1 0 1 0 as group 1, while group 2 is fully programmable (see Fig.12).

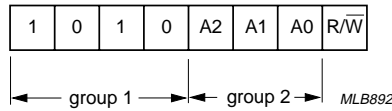
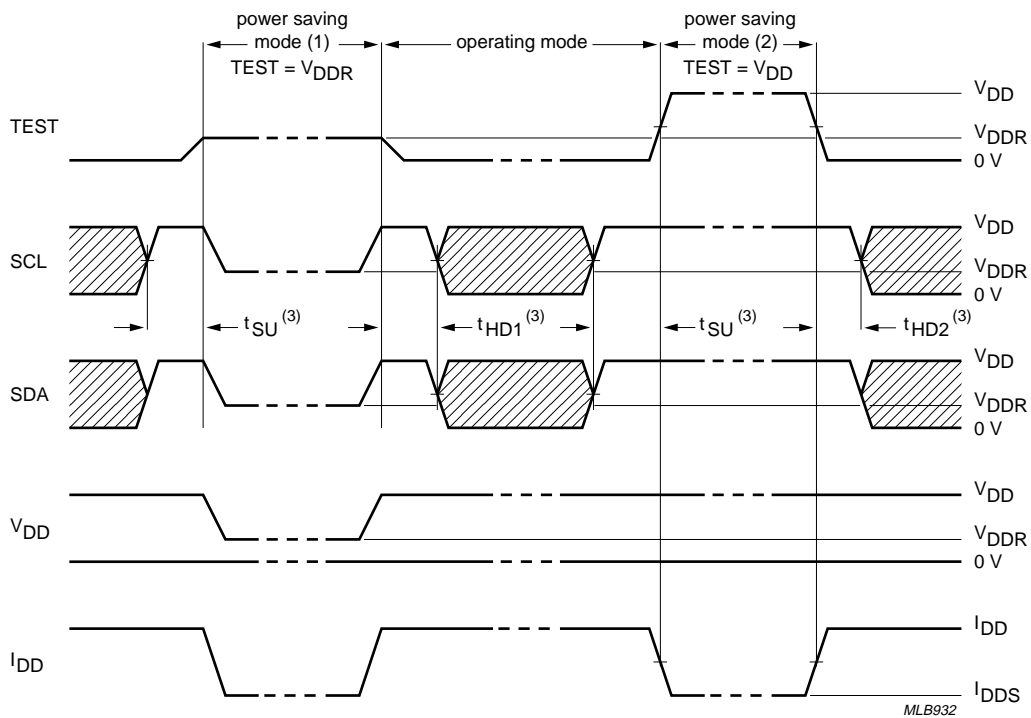

Fig.12 Slave address.

13.3 Power-saving mode

With the condition TEST = V<sub>DD</sub> or V<sub>DDR</sub> the PCF8570 goes into the power-saving mode and I<sup>2</sup>C-bus logic is reset.



- (1) Power-saving mode without 5 V supply voltage.
- (2) Power-saving mode with 5 V supply voltage.
- (3) t<sub>SU</sub> and t<sub>HD1</sub> ≥ 4 μs and t<sub>HD2</sub> ≥ 50 μs.

Fig.13 Timing for power-saving mode.

256 × 8-bit static low-voltage RAM with I<sup>2</sup>C-bus interface

PCF8570

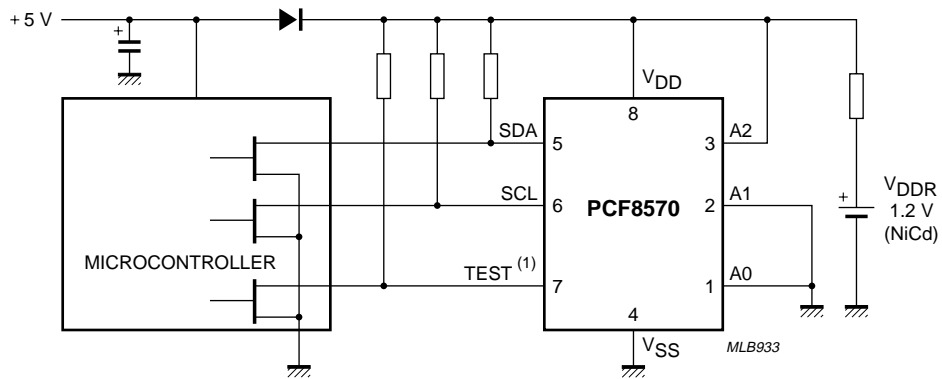

It is recommended that a 4.7 μF/10 V solid aluminium capacitor (SAL) be connected between V<sub>DD</sub> and V<sub>SS</sub>.

(1) In the operating mode TEST = 0 V; in the power-saving mode TEST = V<sub>DDR</sub>.

Fig.14 Application example for power-saving mode.

256 × 8-bit static low-voltage RAM with I<sup>2</sup>C-bus interface

PCF8570

14 PACKAGE OUTLINES

DIP8: plastic dual in-line package; 8 leads (300 mil)

SOT97-1

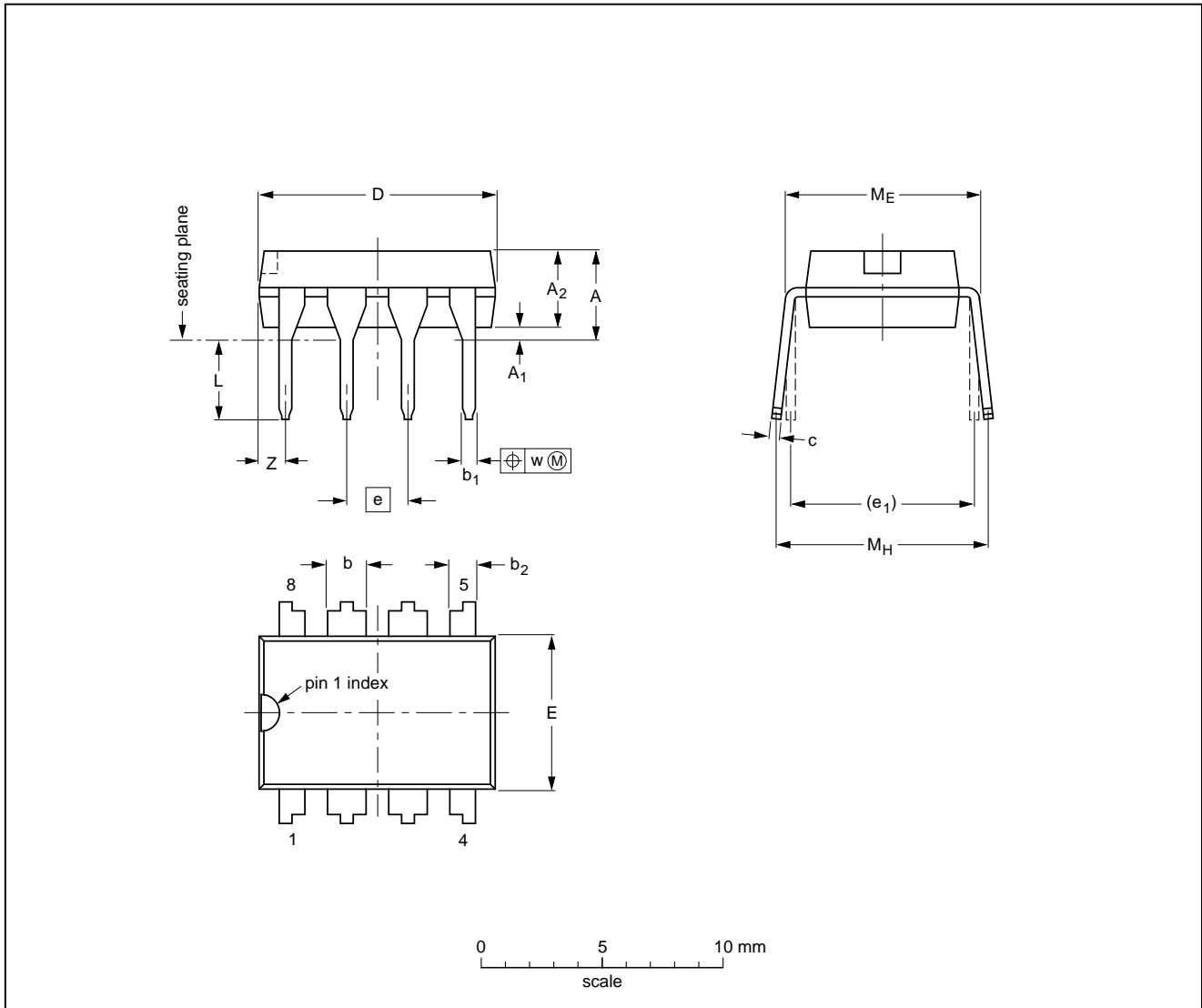

DIMENSIONS (inch dimensions are derived from the original mm dimensions)

UNIT	A max.	A <sub>1</sub> min.	A <sub>2</sub> max.	b	b <sub>1</sub>	b <sub>2</sub>	c	D <sup>(1)</sup>	E <sup>(1)</sup>	e	e <sub>1</sub>	L	M <sub>E</sub>	M <sub>H</sub>	w	Z <sup>(1)</sup> max.
mm	4.2	0.51	3.2	1.73 1.14	0.53 0.38	1.07 0.89	0.36 0.23	9.8 9.2	6.48 6.20	2.54	7.62	3.60 3.05	8.25 7.80	10.0 8.3	0.254	1.15
inches	0.17	0.020	0.13	0.068 0.045	0.021 0.015	0.042 0.035	0.014 0.009	0.39 0.36	0.26 0.24	0.10	0.30	0.14 0.12	0.32 0.31	0.39 0.33	0.01	0.045

Note

1. Plastic or metal protrusions of 0.25 mm maximum per side are not included.

OUTLINE VERSION	REFERENCES				EUROPEAN PROJECTION	ISSUE DATE
	IEC	JEDEC	EIAJ			
SOT97-1	050G01	MO-001AN				92-11-17 95-02-04

256 × 8-bit static low-voltage RAM with I<sup>2</sup>C-bus interface

PCF8570

SO8: plastic small outline package; 8 leads; body width 7.5 mm

SOT176-1

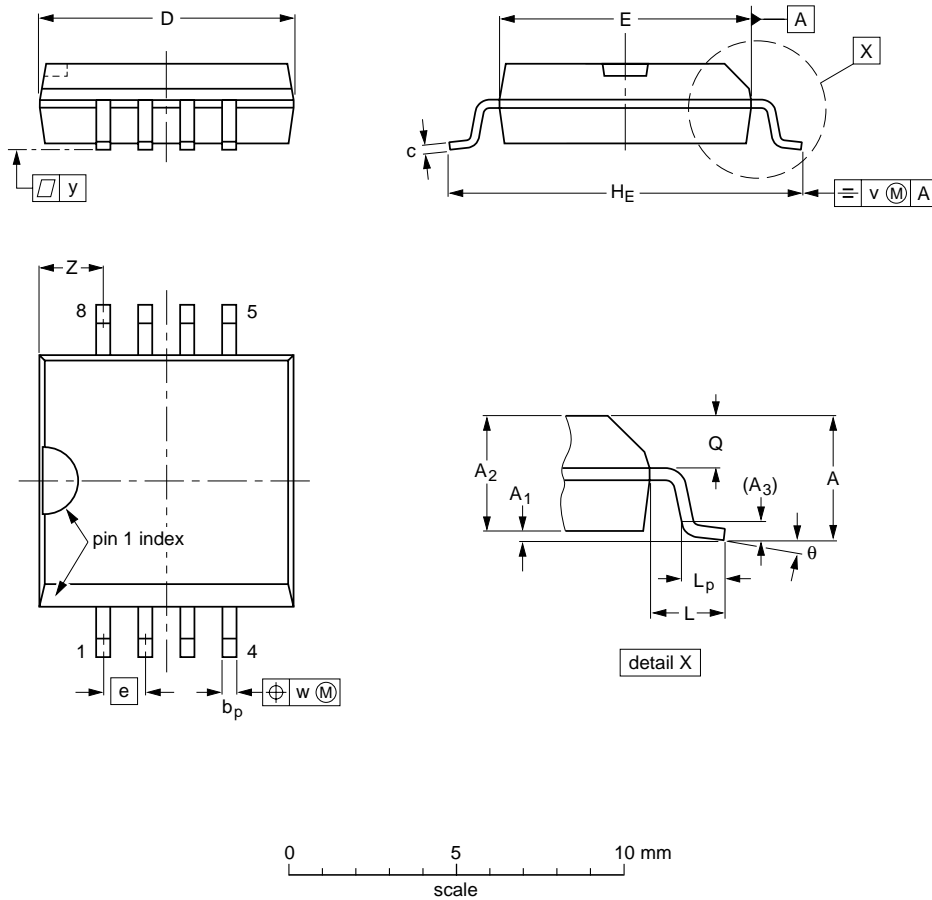

DIMENSIONS (inch dimensions are derived from the original mm dimensions)

UNIT	A max.	A <sub>1</sub>	A <sub>2</sub>	A <sub>3</sub>	b <sub>p</sub>	c	D <sup>(1)</sup>	E <sup>(1)</sup>	e	H <sub>E</sub>	L	L <sub>p</sub>	Q	v	w	y	Z <sup>(1)</sup>	θ
mm	2.65	0.3 0.1	2.45 2.25	0.25	0.49 0.36	0.32 0.23	7.65 7.45	7.6 7.4	1.27	10.65 10.00	1.45	1.1 0.45	1.1 1.0	0.25	0.25	0.1	2.0 1.8	8° 0°
inches	0.10	0.012 0.004	0.096 0.089	0.01	0.019 0.014	0.013 0.009	0.30 0.29	0.30 0.29	0.050	0.419 0.394	0.057	0.043 0.018	0.043 0.039	0.01	0.01	0.004	0.079 0.071	

Note

1. Plastic or metal protrusions of 0.15 mm maximum per side are not included.

OUTLINE VERSION	REFERENCES			EUROPEAN PROJECTION	ISSUE DATE
	IEC	JEDEC	EIAJ		
SOT176-1					95-02-25 97-05-22

## 256 × 8-bit static low-voltage RAM with I<sup>2</sup>C-bus interface

PCF8570

### 15 SOLDERING

#### 15.1 Introduction

This text gives a very brief insight to a complex technology. A more in-depth account of soldering ICs can be found in our *"Data Handbook IC26; Integrated Circuit Packages"* (document order number 9398 652 90011).

There is no soldering method that is ideal for all IC packages. Wave soldering is often preferred when through-hole and surface mount components are mixed on one printed-circuit board. However, wave soldering is not always suitable for surface mount ICs, or for printed-circuit boards with high population densities. In these situations reflow soldering is often used.

#### 15.2 Through-hole mount packages

##### 15.2.1 SOLDERING BY DIPPING OR BY SOLDER WAVE

The maximum permissible temperature of the solder is 260 °C; solder at this temperature must not be in contact with the joints for more than 5 seconds. The total contact time of successive solder waves must not exceed 5 seconds.

The device may be mounted up to the seating plane, but the temperature of the plastic body must not exceed the specified maximum storage temperature ( $T_{stg(max)}$ ). If the printed-circuit board has been pre-heated, forced cooling may be necessary immediately after soldering to keep the temperature within the permissible limit.

##### 15.2.2 MANUAL SOLDERING

Apply the soldering iron (24 V or less) to the lead(s) of the package, either below the seating plane or not more than 2 mm above it. If the temperature of the soldering iron bit is less than 300 °C it may remain in contact for up to 10 seconds. If the bit temperature is between 300 and 400 °C, contact may be up to 5 seconds.

#### 15.3 Surface mount packages

##### 15.3.1 REFLOW SOLDERING

Reflow soldering requires solder paste (a suspension of fine solder particles, flux and binding agent) to be applied to the printed-circuit board by screen printing, stencilling or pressure-syringe dispensing before package placement.

Several methods exist for reflowing; for example, infrared/convection heating in a conveyor type oven. Throughput times (preheating, soldering and cooling) vary between 100 and 200 seconds depending on heating method.

Typical reflow peak temperatures range from 215 to 250 °C. The top-surface temperature of the packages should preferably be kept below 230 °C.

##### 15.3.2 WAVE SOLDERING

Conventional single wave soldering is not recommended for surface mount devices (SMDs) or printed-circuit boards with a high component density, as solder bridging and non-wetting can present major problems.

To overcome these problems the double-wave soldering method was specifically developed.

If wave soldering is used the following conditions must be observed for optimal results:

- Use a double-wave soldering method comprising a turbulent wave with high upward pressure followed by a smooth laminar wave.
- For packages with leads on two sides and a pitch (e):
  - larger than or equal to 1.27 mm, the footprint longitudinal axis is **preferred** to be parallel to the transport direction of the printed-circuit board;
  - smaller than 1.27 mm, the footprint longitudinal axis **must** be parallel to the transport direction of the printed-circuit board.

The footprint must incorporate solder thieves at the downstream end.

- For packages with leads on four sides, the footprint must be placed at a 45° angle to the transport direction of the printed-circuit board. The footprint must incorporate solder thieves downstream and at the side corners.

During placement and before soldering, the package must be fixed with a droplet of adhesive. The adhesive can be applied by screen printing, pin transfer or syringe dispensing. The package can be soldered after the adhesive is cured.

Typical dwell time is 4 seconds at 250 °C.

A mildly-activated flux will eliminate the need for removal of corrosive residues in most applications.

##### 15.3.3 MANUAL SOLDERING

Fix the component by first soldering two diagonally-opposite end leads. Use a low voltage (24 V or less) soldering iron applied to the flat part of the lead. Contact time must be limited to 10 seconds at up to 300 °C.

When using a dedicated tool, all other leads can be soldered in one operation within 2 to 5 seconds between 270 and 320 °C.



## 256 × 8-bit static low-voltage RAM with I<sup>2</sup>C-bus interface

PCF8570

### 15.4 Suitability of IC packages for wave, reflow and dipping soldering methods

MOUNTING	PACKAGE	SOLDERING METHOD		
		WAVE	REFLOW <sup>(1)</sup>	DIPPING
Through-hole mount	DBS, DIP, HDIP, SDIP, SIL	suitable <sup>(2)</sup>	–	suitable
Surface mount	BGA, SQFP	not suitable	suitable	–
	HLQFP, HSQFP, HSOP, HTSSOP, SMS	not suitable <sup>(3)</sup>	suitable	–
	PLCC <sup>(4)</sup> , SO, SOJ	suitable	suitable	–
	LQFP, QFP, TQFP	not recommended <sup>(4)(5)</sup>	suitable	–
	SSOP, TSSOP, VSO	not recommended <sup>(6)</sup>	suitable	–

#### Notes

- All surface mount (SMD) packages are moisture sensitive. Depending upon the moisture content, the maximum temperature (with respect to time) and body size of the package, there is a risk that internal or external package cracks may occur due to vaporization of the moisture in them (the so called popcorn effect). For details, refer to the Drypack information in the *"Data Handbook IC26; Integrated Circuit Packages; Section: Packing Methods"*.
- For SDIP packages, the longitudinal axis must be parallel to the transport direction of the printed-circuit board.
- These packages are not suitable for wave soldering as a solder joint between the printed-circuit board and heatsink (at bottom version) can not be achieved, and as solder may stick to the heatsink (on top version).
- If wave soldering is considered, then the package must be placed at a 45° angle to the solder wave direction. The package footprint must incorporate solder thieves downstream and at the side corners.
- Wave soldering is only suitable for LQFP, QFP and TQFP packages with a pitch (e) equal to or larger than 0.8 mm; it is definitely not suitable for packages with a pitch (e) equal to or smaller than 0.65 mm.
- Wave soldering is only suitable for SSOP and TSSOP packages with a pitch (e) equal to or larger than 0.65 mm; it is definitely not suitable for packages with a pitch (e) equal to or smaller than 0.5 mm.

## 256 × 8-bit static low-voltage RAM with I<sup>2</sup>C-bus interface

PCF8570

### 16 DEFINITIONS

<b>Data sheet status</b>	
Objective specification	This data sheet contains target or goal specifications for product development.
Preliminary specification	This data sheet contains preliminary data; supplementary data may be published later.
Product specification	This data sheet contains final product specifications.
<b>Limiting values</b>	
Limiting values given are in accordance with the Absolute Maximum Rating System (IEC 134). Stress above one or more of the limiting values may cause permanent damage to the device. These are stress ratings only and operation of the device at these or at any other conditions above those given in the Characteristics sections of the specification is not implied. Exposure to limiting values for extended periods may affect device reliability.	
<b>Application information</b>	
Where application information is given, it is advisory and does not form part of the specification.	

### 17 LIFE SUPPORT APPLICATIONS

These products are not designed for use in life support appliances, devices, or systems where malfunction of these products can reasonably be expected to result in personal injury. Philips customers using or selling these products for use in such applications do so at their own risk and agree to fully indemnify Philips for any damages resulting from such improper use or sale.

### 18 PURCHASE OF PHILIPS I<sup>2</sup>C COMPONENTS



Purchase of Philips I<sup>2</sup>C components conveys a license under the Philips' I<sup>2</sup>C patent to use the components in the I<sup>2</sup>C system provided the system conforms to the I<sup>2</sup>C specification defined by Philips. This specification can be ordered using the code 9398 393 40011.

---

256 × 8-bit static low-voltage RAM with  
I<sup>2</sup>C-bus interface

---

PCF8570

**NOTES**

# Philips Semiconductors – a worldwide company

**Argentina:** see South America

**Australia:** 34 Waterloo Road, NORTH RYDE, NSW 2113, Tel. +61 2 9805 4455, Fax. +61 2 9805 4466

**Austria:** Computerstr. 6, A-1101 WIEN, P.O. Box 213, Tel. +43 1 60 101 1248, Fax. +43 1 60 101 1210

**Belarus:** Hotel Minsk Business Center, Bld. 3, r. 1211, Volodarski Str. 6, 220050 MINSK, Tel. +375 172 20 0733, Fax. +375 172 20 0773

**Belgium:** see The Netherlands

**Brazil:** see South America

**Bulgaria:** Philips Bulgaria Ltd., Energoproject, 15th floor, 51 James Bourchier Blvd., 1407 SOFIA, Tel. +359 2 68 9211, Fax. +359 2 68 9102

**Canada:** PHILIPS SEMICONDUCTORS/COMPONENTS, Tel. +1 800 234 7381, Fax. +1 800 943 0087

**China/Hong Kong:** 501 Hong Kong Industrial Technology Centre, 72 Tat Chee Avenue, Kowloon Tong, HONG KONG, Tel. +852 2319 7888, Fax. +852 2319 7700

**Colombia:** see South America

**Czech Republic:** see Austria

**Denmark:** Sydhavnsgade 23, 1780 COPENHAGEN V, Tel. +45 33 29 3333, Fax. +45 33 29 3905

**Finland:** Sinikalliontie 3, FIN-02630 ESPOO, Tel. +358 9 615 800, Fax. +358 9 6158 0920

**France:** 51 Rue Carnot, BP317, 92156 SURESNES Cedex, Tel. +33 1 4099 6161, Fax. +33 1 4099 6427

**Germany:** Hammerbrookstraße 69, D-20097 HAMBURG, Tel. +49 40 2353 60, Fax. +49 40 2353 6300

**Greece:** No. 15, 25th March Street, GR 17778 TAVROS/ATHENS, Tel. +30 1 489 4339/4239, Fax. +30 1 481 4240

**Hungary:** see Austria

**India:** Philips INDIA Ltd, Band Box Building, 2nd floor, 254-D, Dr. Annie Besant Road, Worli, MUMBAI 400 025, Tel. +91 22 493 8541, Fax. +91 22 493 0966

**Indonesia:** PT Philips Development Corporation, Semiconductors Division, Gedung Philips, Jl. Buncit Raya Kav.99-100, JAKARTA 12510, Tel. +62 21 794 0040 ext. 2501, Fax. +62 21 794 0080

**Ireland:** Newstead, Clonskeagh, DUBLIN 14, Tel. +353 1 7640 000, Fax. +353 1 7640 200

**Israel:** RAPAC Electronics, 7 Kehilat Saloniki St, PO Box 18053, TEL AVIV 61180, Tel. +972 3 645 0444, Fax. +972 3 649 1007

**Italy:** PHILIPS SEMICONDUCTORS, Piazza IV Novembre 3, 20124 MILANO, Tel. +39 2 6752 2531, Fax. +39 2 6752 2557

**Japan:** Philips Bldg 13-37, Kohnan 2-chome, Minato-ku, TOKYO 108-8507, Tel. +81 3 3740 5130, Fax. +81 3 3740 5077

**Korea:** Philips House, 260-199 Itaewon-dong, Yongsan-ku, SEOUL, Tel. +82 2 709 1412, Fax. +82 2 709 1415

**Malaysia:** No. 76 Jalan Universiti, 46200 PETALING JAYA, SELANGOR, Tel. +60 3 750 5214, Fax. +60 3 757 4880

**Mexico:** 5900 Gateway East, Suite 200, EL PASO, TEXAS 79905, Tel. +9-5 800 234 7381, Fax +9-5 800 943 0087

**Middle East:** see Italy

**Netherlands:** Postbus 90050, 5600 PB EINDHOVEN, Bldg. VB, Tel. +31 40 27 82785, Fax. +31 40 27 88399

**New Zealand:** 2 Wagener Place, C.P.O. Box 1041, AUCKLAND, Tel. +64 9 849 4160, Fax. +64 9 849 7811

**Norway:** Box 1, Manglerud 0612, OSLO, Tel. +47 22 74 8000, Fax. +47 22 74 8341

**Pakistan:** see Singapore

**Philippines:** Philips Semiconductors Philippines Inc., 106 Valero St. Salcedo Village, P.O. Box 2108 MCC, MAKATI, Metro MANILA, Tel. +63 2 816 6380, Fax. +63 2 817 3474

**Poland:** Ul. Lukiska 10, PL 04-123 WARSZAWA, Tel. +48 22 612 2831, Fax. +48 22 612 2327

**Portugal:** see Spain

**Romania:** see Italy

**Russia:** Philips Russia, Ul. Usatcheva 35A, 119048 MOSCOW, Tel. +7 095 755 6918, Fax. +7 095 755 6919

**Singapore:** Lorong 1, Toa Payoh, SINGAPORE 319762, Tel. +65 350 2538, Fax. +65 251 6500

**Slovakia:** see Austria

**Slovenia:** see Italy

**South Africa:** S.A. PHILIPS Pty Ltd., 195-215 Main Road Martindale, 2092 JOHANNESBURG, P.O. Box 7430 Johannesburg 2000, Tel. +27 11 470 5911, Fax. +27 11 470 5494

**South America:** Al. Vicente Pinzon, 173, 6th floor, 04547-130 SÃO PAULO, SP, Brazil, Tel. +55 11 821 2333, Fax. +55 11 821 2382

**Spain:** Balmes 22, 08007 BARCELONA, Tel. +34 93 301 6312, Fax. +34 93 301 4107

**Sweden:** Kottbygatan 7, Akalla, S-16485 STOCKHOLM, Tel. +46 8 5985 2000, Fax. +46 8 5985 2745

**Switzerland:** Allmendstrasse 140, CH-8027 ZÜRICH, Tel. +41 1 488 2741 Fax. +41 1 488 3263

**Taiwan:** Philips Semiconductors, 6F, No. 96, Chien Kuo N. Rd., Sec. 1, TAIPEI, Taiwan Tel. +886 2 2134 2865, Fax. +886 2 2134 2874

**Thailand:** PHILIPS ELECTRONICS (THAILAND) Ltd., 209/2 Sanpavuth-Bangna Road Prakanong, BANGKOK 10260, Tel. +66 2 745 4090, Fax. +66 2 398 0793

**Turkey:** Talatpasa Cad. No. 5, 80640 GÜLTEPE/ISTANBUL, Tel. +90 212 279 2770, Fax. +90 212 282 6707

**Ukraine:** PHILIPS UKRAINE, 4 Patrice Lumumba str., Building B, Floor 7, 252042 KIEV, Tel. +380 44 264 2776, Fax. +380 44 268 0461

**United Kingdom:** Philips Semiconductors Ltd., 276 Bath Road, Hayes, MIDDLESEX UB3 5BX, Tel. +44 181 730 5000, Fax. +44 181 754 8421

**United States:** 811 East Arques Avenue, SUNNYVALE, CA 94088-3409, Tel. +1 800 234 7381, Fax. +1 800 943 0087

**Uruguay:** see South America

**Vietnam:** see Singapore

**Yugoslavia:** PHILIPS, Trg N. Pasica 5/v, 11000 BEOGRAD, Tel. +381 11 62 5344, Fax. +381 11 63 5777

**For all other countries apply to:** Philips Semiconductors, International Marketing & Sales Communications, Building BE-p, P.O. Box 218, 5600 MD EINDHOVEN, The Netherlands, Fax. +31 40 27 24825

**Internet:** <http://www.semiconductors.philips.com>

© Philips Electronics N.V. 1999

SCA61

All rights are reserved. Reproduction in whole or in part is prohibited without the prior written consent of the copyright owner.

The information presented in this document does not form part of any quotation or contract, is believed to be accurate and reliable and may be changed without notice. No liability will be accepted by the publisher for any consequence of its use. Publication thereof does not convey nor imply any license under patent- or other industrial or intellectual property rights.

Printed in The Netherlands

415106/00/04/pp20

Date of release: 1999 Jan 06

Document order number: 9397 750 04971

*Let's make things better.*

**Philips  
Semiconductors**



**PHILIPS**

This datasheet has been download from:

[www.datasheetcatalog.com](http://www.datasheetcatalog.com)

Datasheets for electronics components.