

Oct. 13, 1925.

1,556,964

A. SCHERBIUS

ELECTRIC CIPHERING APPARATUS

Filed April 20, 1922

2 Sheets-Sheet 2

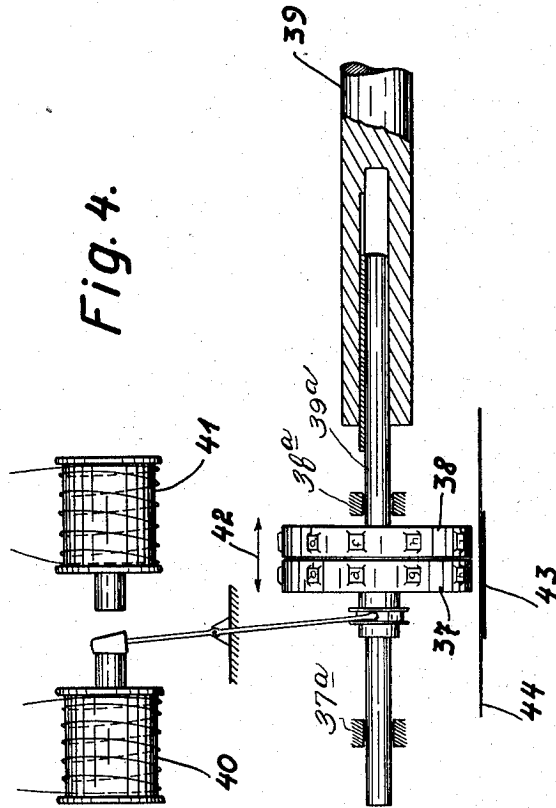
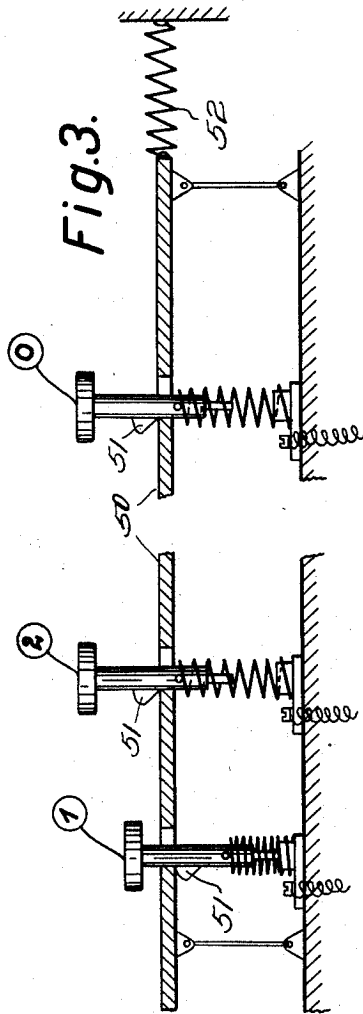

Inventor
A. Scherbius,
By Marks & Clerk
Attys

UNITED STATES PATENT OFFICE.

ARTHUR SCHERBIUS, OF BERLIN, GERMANY, ASSIGNOR TO THE FIRM GEWERKSCHAFT SECURITAS, OF BERLIN, GERMANY, A COMPANY OF GERMANY.

ELECTRIC CIPHERING APPARATUS.

Application filed April 20, 1922. Serial No. 555,678.

To all whom it may concern:

Be it known that I, ARTHUR SCHERBIUS, a citizen of the German Republic, residing at Berlin, Germany, have invented certain new and useful Improvements in an Electric Ciphering Apparatus, of which the following is a specification.

For various reasons it is advisable to use characters instead of figures in cipher telegrams. It is especially advisable to alternate vowels and consonants in such succession that in the ciphered text no accumulation of consonants occurs but words are formed which can be pronounced and which at the transmission of the ciphered text, for instance by telegram, do not give cause for errors.

The apparatus according to this invention is a machine which is of simple construction, easy to manipulate and readable directly.

The apparatus is shown by way of example on the accompanying drawing, wherein:—

Fig. 1 shows the apparatus in plan view.

Fig. 2 is a diagram of a connection.

Fig. 3 shows diagrammatically on enlarged scale a mechanical coupling of the figure contacts.

Fig. 4 shows an arrangement comprising revolving type wheels, also on enlarged scale and diagrammatically.

The apparatus consists of a switch board with two rows of contacts VII and VIII for figures and with two rows of indicators I and II, for instance incandescent electric lamps, for the letters. These rows are designed for the ciphering. Similar rows III and IV (contact rows) and rows V and VI (indicator rows) serve for deciphering. The first row VII of figure contacts is subdivided into two or more groups and corresponding figure contacts of each group are connected to a common letter indicator (incandescent lamp) of row I.

As can be seen from Fig. 1 of the drawing the first row I of the letter indicators is short as it contains only vowels, the second row II of the letter indicator which contains the consonants, being long. Each figure contact of the second figure row VIII is connected with two or more letter indicators (incandescent lamps) of row II, this connecting being again dependent on

the groups of the first row of figure contacts VII as will be hereinafter explained. 55

The parts 11 and 12 are multiple switch boards which connect each arriving lead with one of the outgoing leads and which are adapted to interchange this connection with great facility of variation. These 60 switch boards could be arranged so that the connections are changed constantly, viz., after each group of two signs and that this change is effected automatically at the depression of the contact keys. The multiple 65 switch boards 11 and 12 improve considerably the security of the ciphering but they are not of fundamental importance for the character of the invention.

As can be seen from the connection diagram of Fig. 2 corresponding contacts of the two groups of the row VII of the figure contacts are connected by a common lead 15 across the multiple switch board 12 with a common indicator of row I. From here the 75 lead 31 conducts over a throw-over switch 18 through lead 32 to the battery 20 and over lead 33 and throw-over switch 17 through lead 34 to the contacts of the second row of contacts VIII. Thence the leads 14 80 conduct across the multiple switch board 11 by means of leads 13 each to two indicators of the indicator row II which are connected by the collecting leads 35 and 36 in two 85 groups. The end of the two collecting leads 35 36 is connected by a throw-over switch 19 with the leads 25 and 26 of the two groups of the contact row VII.

If the throw-over switches 17, 18, 19 are put to ciphering in the direction of the arrow A, one indicator in each of the indicator rows I and II will be operated at the simultaneous closing of a contact in each of the contact rows VII and VIII, for instance incandescent lamps will be lighted as indicators. 95

The current flows for the ciphering process in the manner which will be hereinafter explained as an example.

If the number "14" has to be ciphered the contact 1 in the row VII of contact keys 100 and the contact 4 in the row VIII have to be closed. The current flows then as indicated by dash-lines (short dashes). From the contact 1 in row VII it flows through lead 15 to 105 the multiple switch board 12, from there

through lead 16 to the indicator *i* of the indicator row I, from there through lead 31 across throw-over switch 18, lead 32 to battery 20, lead 33, throw-over switch 17, lead 5 34 to the contact 4 of the second row of contacts VIII, through lead 14 to the multiple switch board 11 and lead 13 to the indicator *g*. From there through lead 21 to the collecting lead 35 and a cross switch 19, lead 10 25 back to the contact 1.

In this case the indicator *g* has been selected of the two indicators *g* and *h* which are both connected with the lead 13 as in the first row of Figures VII a contact of the 15 left hand side group (viz 1) has been closed. If instead of a contact of the left hand side group of this row VII a contact of the right hand side group, for instance the contact 6 had been closed the course of the current would have been from point 24 of lead 20 13 as follows, (dash lines with long dashes):—Indicator *h*, collecting line 36, switch 19, lead 26 back to the contact 6. In this manner the indicator *h* would have been 25 selected.

From the connection diagram it can be seen that the ten contacts, row VIII, do not alone determine the letters of the row II but that for the determination of these letters 30 it is further decisive whether a contact is depressed in the left hand side or in the right hand side group of row VII.

The deciphering of the group of letters *i g* is effected, after the shifting of the 35 throw-over switches 17, 18, 19 into the deciphering position B by depression of the contacts *i* or *g* in rows III and IV. The course of the current is indicated by the dash and dot lines. In the deciphering 40 mechanism proper the course of current is the same as at the ciphering only the lamps have been interchanged by the switches with the correspondingly situated and similarly designated contacts and inversely 45 (see Figs. 1 and 2).

As can be seen from the diagram of connection one of the keys of row VII must always be depressed simultaneously with one of the keys of row VIII and at the deciphering one of the keys of the rows III 50 with one of the rows IV must be depressed simultaneously.

In order to avoid that two hands have to be used for operating, the keys of the four 55 rows III, IV, VII and VIII are preferably mechanically coupled with one another in such a manner that the keys remain, after depression, in the switching on position and jump out only if another button in the same 60 row is depressed. Arrangements of this type are generally known from the technics of the telephone.

If for instance the key 1 of row VII and 65 the key 4 of row VIII are depressed both contacts remain closed so that the ciphering

letters can be read at leisure from the incandescent lamps. If now a new group of two figures is switched in, the keys 1 and 4 jump automatically to the initial position. This can be effected, for example, by providing a movable rod 50 for each contact 70 plug series and arranging wedge-shaped lugs 51 at the contact plugs. The rod 50 holds the contact plugs in the contact position until, by depressing another contact 75 plug of the same series, the rod is moved against the action of the spring 52 by means of the lug 51 provided on the contact plugs so that the rod releases the lug 51 of the first depressed plug which, until then 80 also retained in a depressed position, and thus permits the last mentioned lug to snap upwardly again. The arrangement could further be such that the contacts of the upper rows are lifted only then if the con- 85 tacts of the lower row are lifted also.

The invention is not limited to the use of incandescent lamps it can be applied also in connection with directly recording mechanisms, magnets being for instance substituted for the incandescent lamps, said magnets operating key levers. Revolving type 90 wheels or type wheels with limiting stops with or without throwing over could be used. 95

The type wheels 37, 38 are arranged on a common shaft 39^a and constantly rotate thereon at a uniform speed. The shaft 39^a with the type wheels is mounted in suitable bearings 37^a and 38^a and movable longitudinally and is set in rotation by means of a suitable drive mechanism such, for instance, as an electric motor coupled with the shaft 39. The periphery of one of the type wheels is provided with type letters *b, d, g, h, n, p, r, t, w* and *y*, and the other type wheel with the letters *a, f, h, l, m, q, s, v, x*, and *z*. The last mentioned group of letters being arranged parallel with the letters of the first mentioned group in the order named. 100 105 110

By electromagnets 40 and 41 inserted in the lead at 25 and 26 or at 35 and 36 the type wheels would be displaced in the direction of the arrows 42 so that one letter of the one or the other row of letters is printed upon the paper 44 placed upon the paper support 43 so that the same effect is obtained as with incandescent lamps. Evidently the paper could be shifted and the type wheels could be stationary. 115 120

I claim:—

1. A ciphering or deciphering machine for the transformation of a succession of figures into a succession of letters or inversely, consisting of two rows of contacts of equal length for the figures and of two rows of indicators for the letters, the first contact row for the figures being subdivided into groups, the corresponding figure contacts of the several groups being connected 125 130

with a common letter indicator of the first row of letter indicators and one figure contact of the second row of figures being connected with several letter indicators of the second indicator row, leads for connecting the figure contacts with the letter indicators and a source of current inserted in said leads.

2. A ciphering or deciphering machine for the transformation of a succession of figures into a succession of letters or inversely consisting of two rows of contacts of equal length for the figures and of a long row and a short row of indicators for the letters, the first contact row for the figures being subdivided into groups, the corresponding contacts of the several groups being connected with a common letter indicator of the short row of letter indicators and one figure contact of the second row of figures being connected with several letter indicators of the long indicator row, leads for connecting the figure contacts with the letter indicators, multiple switch boards and a source of current inserted in said leads.

3. A ciphering or deciphering machine for the transformation of a succession of figures into a succession of letters or inversely consisting of two rows of contacts of equal length for the figures and of a long row and a short row of indicators for the letters, the first contact row for the figures being subdivided into groups, the corresponding contacts of the several groups being connected with a common letter indicator of the short row of letter indicators and one figure contact of the second row of figures being connected with several letter indicators of the long indicator row, leads for connecting the figure contacts with the letter indicators, letter contacts at the side of the letter indicators, and figure indicators at the side of the figure contacts inserted in all the individual circuits of all groups for the purpose of deciphering, multiple switch boards and a source of current inserted in said leads, throw-over switches for reversing from ciphering to deciphering.

4. A ciphering and deciphering machine for the transformation of a succession of figures into a succession of letters or inversely consisting of two rows of contacts of equal length for the figures and of a long row and of a short row of indicators for the letters, the first contact row for the figures being subdivided into two groups, of which one figure contact of each of these two groups is connected to a common letter indicator of the short row, each figure contact of the second row of figures being connected to several letter indicators of the long row, circuits for connecting each of the groups of letter indicators with one group of the first row of figure contacts.

5. A ciphering and deciphering machine for the transformation of a succession of figures into a succession of letters or inversely consisting of two rows of contacts of equal length for the figures and of a long row and of a short row of indicators for the letters, the first contact row for the figures being subdivided into two groups, of which one figure contact of each of these two groups is connected to a common letter indicator of the short row, each figure contact of the second row of figures being connected to several letter indicators of the long row, circuits for connecting the groups of letter indicators with one group of the first row of figure contacts, multiple switch boards inserted one between the first figure contact row and the short letter indicator row and one between the second figure contact row and the long letter indicator row and a source of current inserted in the circuits.

6. A ciphering and deciphering machine for the transformation of a succession of figures into a succession of letters or inversely consisting of two rows of contacts of equal length for the figures and of a long row and of a short row of indicators for the letters, the first contact row for the figures being subdivided into two groups, of which one figure contact of each of these two groups is connected to a common letter indicator of the short row, each figure contact of the second row of figures being connected to several letter indicators of the long row, circuits for connecting the groups of letter indicators with one group of the first row of figure contacts, letter contacts at the side of the letter indicators and figure indicators at the side of the figure contacts inserted in all individual circuits of all groups for the purpose of deciphering, multiple switch boards inserted between the several figure contact rows and the corresponding letter indicator rows, a source of current inserted in the circuits, and throw-over switches for reversing from ciphering to deciphering.

7. A ciphering and deciphering machine for the transformation of a succession of figures into a succession of letters or inversely consisting of two rows of contacts of equal length for the figures and of a long row and of a short row of indicators for the letters, the first contact row for the figures being subdivided into two groups of which one figure contact of each of these two groups is connected to a common letter indicator of the short row each figure contact of the second row of figures being connected to several letter indicators of the long row, circuits for connecting the groups of letter indicators with one group of the first row of figure contacts the contacts of each row having means for automatically

cutting out the operated contact as soon as a contact of the same row is depressed, and a source of current inserted in the circuit.

8. A ciphering and deciphering machine for the transformation of a succession of figures into a succession of letters or inversely consisting of two rows of contacts of equal length for the figures and of a long row and of a short row of indicators for the letters, the first contact row for the figures being subdivided into two groups, of which one figure contact of each of these two groups is connected to a common letter indicator of the short row, each figure contact of the second row of figures being connected to several letter indicators of the long row, circuits for connecting the groups of letter indicators with one group of the first row of figure contacts, movable type wheels carrying groups of letters or of figures, electromagnets inserted in the circuits between the contact rows and the indicator rows, and means designed to displace by the magnets the type wheels for the selection of a determined group, multiple switch boards, and a source of current inserted in the circuit.

In testimony whereof I affix my signature.

ARTHUR SCHERBIUS.