

Dec. 23, 1924.

1,520,089

A. SCHERBIUS

ELECTRIC TYPEWRITING MACHINE

Filed Feb. 15, 1924

3 Sheets-Sheet 1

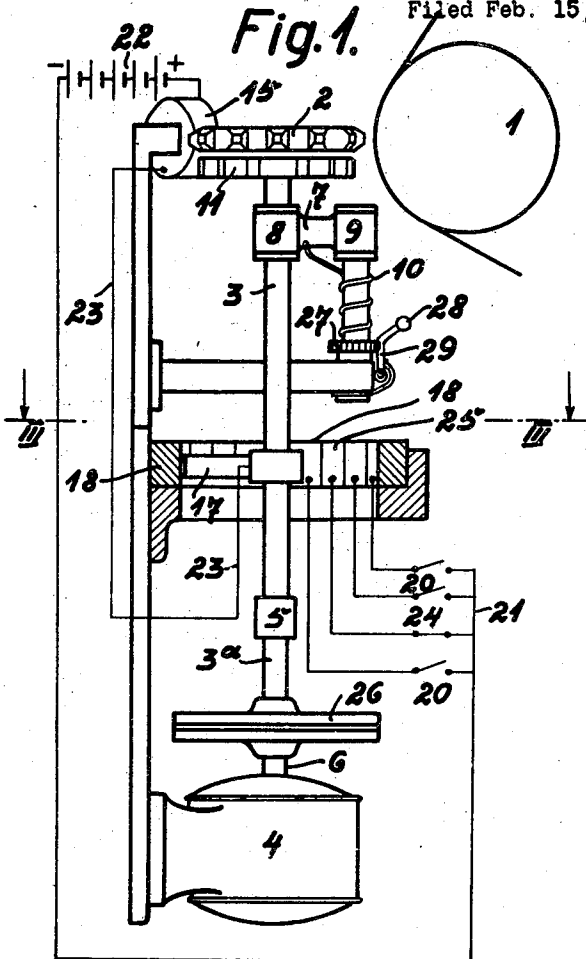

Fig. 3.

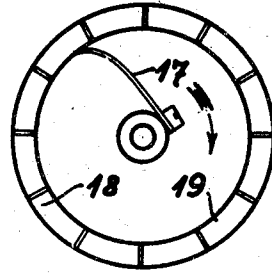

Fig. 4.

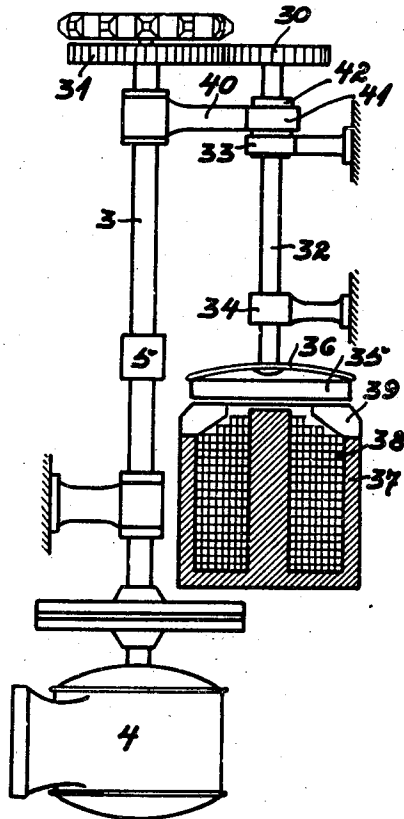
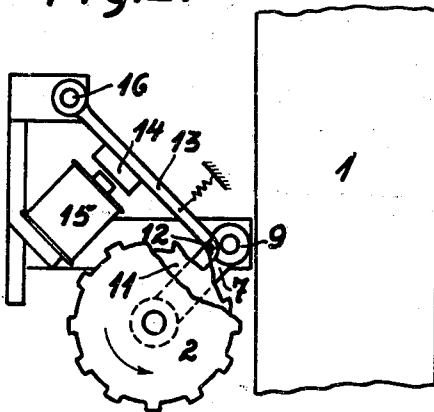

Fig. 2.



Inventor
A. Scherbius
By Mark & Clark
ATTYS.

Dec. 23, 1924.

1,520,089

A. SCHERBIUS

ELECTRIC TYPEWRITING MACHINE

Filed Feb. 15, 1924

3 Sheets-Sheet 2

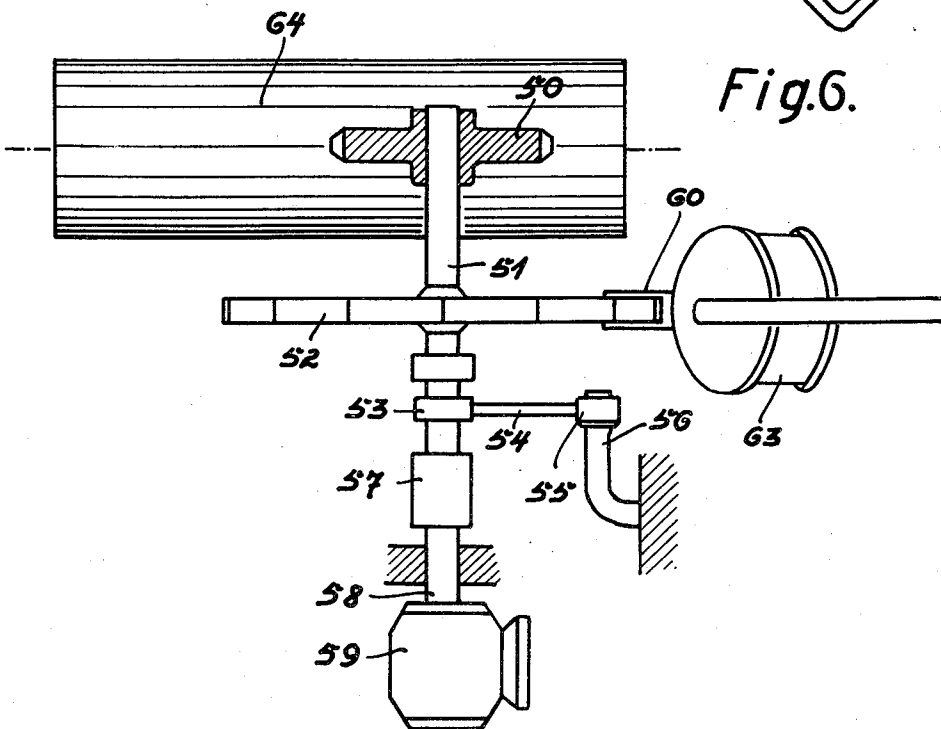
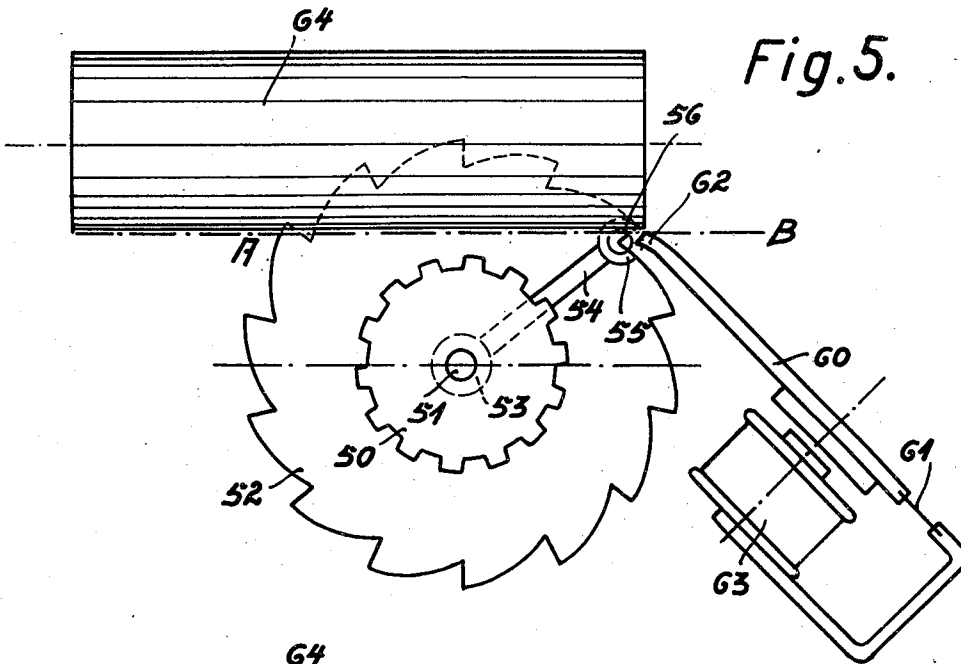

Inventor
A. Scherbius
By Marko Clark
Attys.

Dec. 23, 1924.

1,520,089

A. SCHERBIUS

ELECTRIC TYPEWRITING MACHINE

Filed Feb. 15, 1924

3 Sheets-Sheet 3

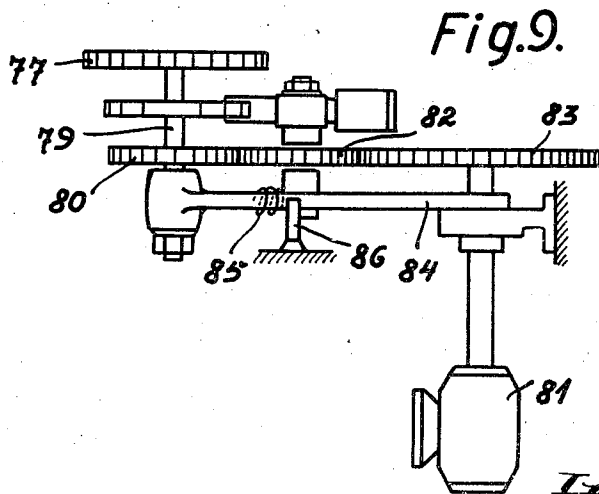
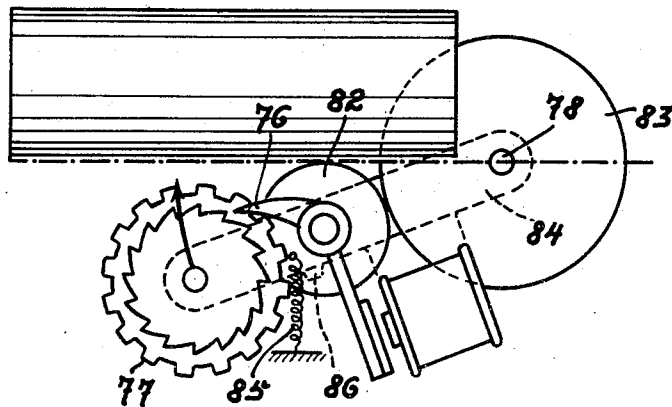
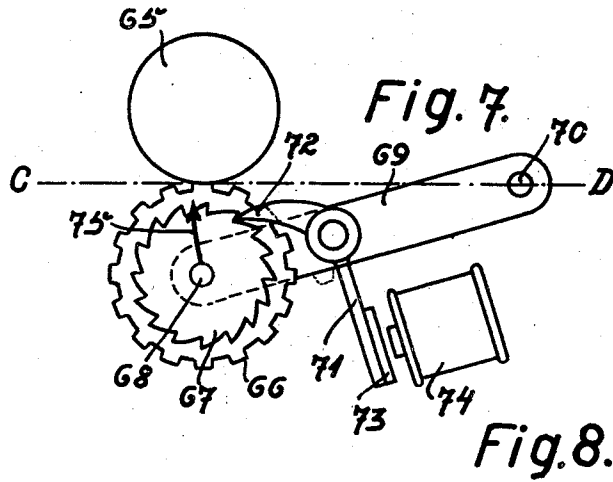

Inventor
A. Scherbius
By Marko & Clark
ATTORNEYS.

UNITED STATES PATENT OFFICE.

ARTHUR SCHERBIUS, OF BERLIN-WANNSEE, GERMANY.

ELECTRIC TYPEWRITING MACHINE.

Application filed February 15, 1924. Serial No. 693,113.

To all whom it may concern:

Be it known that I, ARTHUR SCHERBIUS, a citizen of the German Republic, residing at Berlin-Wannsee, Germany, have invented certain new and useful Improvements in an Electric Typewriting Machine, of which the following is a specification.

This invention relates to an electric typewriting machine of specially simple construction. The machine consists of very few strong elements and is consequently very durable and secure in service.

The invention will be best understood from a consideration of the following detailed description taken in connection with the accompanying drawings forming a part of this specification, with the understanding that while on the drawings one embodiment of the invention is disclosed, the invention is not confined to any strict conformity with the showing of the drawings, but may be embodied in any manner which does not make a material departure from the salient features of the invention.

In the drawing:—

Fig. 1 illustrates the principal connection and by way of example the construction of the most important elements of the typewriting machine.

Fig. 2 shows in plan view the top part of the typewriting machine.

Fig. 3 is a section on line III—III of Fig. 1.

Fig. 4 shows another embodiment of the invention.

Fig. 5 shows in plan view certain elements of the machine of modified construction.

Fig. 6 shows in side elevation and partly in section the elements shown in Fig. 5.

Fig. 7 shows in plan view constructional elements of a third form of construction.

Fig. 8 shows in plan view certain elements of a further form of construction.

Fig. 9 is a side elevation of Fig. 8.

Referring to Fig. 1 the typewriting machine comprises a platen 1 and a typewheel 2 keyed on a shaft 3. The shaft 3 is driven from a motor 4. A Cardan joint 5 is inserted in shaft 3. One end of the shaft 3, a piece 6, is rigidly mounted in the motor, the remainder of shaft 3 being adapted to slightly oscillate around the Cardan joint 5. This oscillating movement is guided by a link 7 (Figs. 1 and 2), the bearing 8 of

which embraces the shaft 3. The link 7 is pivoted at 9. A spring 10 presses the shaft 3 and with the same the typewheel 2 into the position shown in Figs. 1 and 2. A ratchet wheel 11 is mounted on shaft 3 under the typewheel 2. A nose 12 of a lever 13 is adapted to engage with this ratchet wheel, the lever being adapted to be oscillated by the armature 14 of an electro-magnet 15. The lever 13 is pivotally mounted in a bearing 16. A brush 17, keyed on shaft 3 (Figs. 1 and 3), slides in a ring 18 constructed like a collector. The ring 18 is composed of segments 19 which are, each one separately, connected with one of the switches 20. The second poles of the switches 20 are connected by a common lead 21 with the pole of a battery 22, the other pole of which is connected with the electro-magnet 15. This electro-magnet is connected with the brush 17 by a lead 23. The switches 20 correspond with the several types of the typewriting machine, and there are as many switches as there are types on the type wheel 2. Every switch 20 corresponds with a lamella of the ring 18.

The operation of the typewriting machine is as follows:—

When the motor 4 has been started the shaft 3 revolves and with it the typewheel 2, the ratchet wheel 11 and the brush 17. If for instance switch 24 is closed, as shown in Fig. 1, the lamella 25 is electrically connected with the negative pole of the battery 22. When the brush 17 comes in contact with the lamella 25 a current flows across the electro-magnet 15 which attracts the armature 14. The nose 12 engages with the ratchet wheel 11 and stops the typewheel at a determined point. A separate electro-magnet may be further provided which serves for making the typewheel strike against the platen 1 or the platen against the typewheel.

By the arrangement shown in Figs. 1 to 3 the arrangement of a separate magnet is avoided as at the moment when the nose arrests one of the teeth of the ratchet wheel 11, the typewheel is made to strike, owing to its kinetic energy, against the platen oscillating around the bearing 9 and to be pulled back by the action of spring 10. As soon as the contact 24 is interrupted the electro-magnet 15 releases the armature 14, the nose 12 releases the ratchet wheel 11

and the motor 4, which had been braked, begins again to run so that a new type can be written.

In order to avoid the braking of the comparatively great mass of the motor two friction clutches 26 may be inserted between the motor 4 and the part 3^a of the shaft, said friction clutches permitting that the typewheel and ratchet wheel rotate normally with the shaft 3, the motor revolving however without drawing along the shaft 3 for the short moment during which the ratchet wheel is stopped by the lever 13. The arrangement might however be of such a kind that the motor 4 is coupled by the same contact or by a separate contact at every depression of a key 20.

The spring 10 is fixed on a small wheel 27 which has noses and with which engages the small stop lever 29 fitted with a handle. By means of the wheel 27 the tension of the spring 10 can be calculated so that the striking force of the typewheel is regulated. For very high typing speed the arrangement shown in Figs. 1 to 3 may be modified as shown in Fig. 4. Instead of the electro-magnet and the lever 13 a toothed wheel 30 is used which meshes with a toothed wheel 31 keyed on shaft 3. This toothed wheel 30 is mounted on a shaft 32 journalled on two bearings 33 and 34 and running normally idle, driven by the toothed wheel 31. The shaft 32 carries at its lower end an iron plate 35 which is elastically adjustable in axial direction. With this object in view it is coupled with the shaft by a spring 36 in such a manner that it is prevented from rotating on shaft 32. A braking magnet 37 arranged opposite plate 35 is adapted to be excited by a coil 38 and has jaws 39. The winding of the brake magnet 37 is inserted at the same point as the magnet 15 in Fig. 1. If current is supplied to the electro-magnet 37 it attracts the plate 35 which is thus strongly pressed upon the jaws 39 of the braking magnet. The comparatively small sized rotating plate 35 is thus braked almost instantaneously. The toothed wheel 31 rotating owing to its kinetic energy and by the power of the motor 4 tends now to further rotate the toothed wheel 30. The shaft 32 which must be comparatively thin is thus slightly torsioned and takes up essentially the kinetic energy of the rotating parts. At the same time it supplies the power to make the type wheel, which rotates around said shaft 32, strike against the platen. For this purpose an arm 40 is arranged in which the shaft 3 is journaled and a head 41 of which surrounds the shaft 32, a cover 42 on this shaft preventing the displacement of the same. The arrangement according to Fig. 4 presents, in comparison with that shown in Figs. 1 and 2, the advantage that hammer-like strokes do not occur as the

masses are not braked suddenly but partly by the friction coupling and partly by elastic forces. Undesirable striking noises are thus avoided and the material is not worn so rapidly so that the machine can serve for a long time. The arrangement shown in Fig. 4 can be further arranged for essentially higher typing speed. The Cardan joint 5 may be avoided if the shaft 3 is sufficiently thin and flexible. Fig. 4 shows that the shaft 32 is held by the collar 42 in such a manner that a slight interval exists between the plate 35 and the jaws 39 and the braking magnet. The collar 42 may be omitted and the plate 35 be keyed directly on shaft 32 so that it is constantly in contact with the jaws 39 of the electro-magnet 37 sliding upon the same when it rotates. For this purpose a continuous small power transmission from toothed wheel 32 to the toothed wheel 30 is necessary. This presents however the advantage that the flanks of the teeth of the two toothed wheels remain constantly in contact with one another, a noiseless working being thus ensured and the further advantage that no time is lost for the attraction of the armature 35 by the braking magnet 37. The braking mechanism according to Fig. 4 is given by way of example only. A band brake operated by an electro-magnet or any other braking mechanism may also be used. In the form of construction shown in Fig. 4 the drive acts upon shaft 3, it could however act also on shaft 32, in which case the movement of the plate 35 for the purpose of braking would be utilized at the same time for uncoupling the same from the driving point.

Figs. 1-4 show a typewriting machine in which the type wheel has a stopping device with one-sided action so that the type wheel strikes against the platen directly after the stop jumps in, the kind of striking of the types on the platen having not been specially considered.

Figs. 5-9 show arrangements in which the type which is actually striking strikes against the paper in exactly or almost exactly perpendicular direction of movement.

According to Figs. 5 and 6 a type wheel 50 is keyed on a shaft 51 on which further a toothed wheel 52 is mounted. The shaft 51 is guided in a bearing 53 fixed to a lever 54. At the other end of the lever a collar 55 is fixed which is mounted upon a stationary pin 56. The shaft 51 is connected by means of a Cardan joint 57 with the shaft 58 of a motor 59 from which it is driven. A lever 60 having a nose 62 engages with the toothed wheel 52, said lever being pivotally mounted at 61 and adapted to be attracted by an electro-magnet 63. The operation of this mechanism is similar to that described with reference to Figs. 1-4. The

characteristics of the arrangement shown in Figs. 5 and 6 consist in that the pivot axle, around which the type wheel executes its striking movement after the nose 62 of lever 60 has come in engagement with the toothed wheel 52, is oscillated in or approximately in the plane of the paper to be typed. If (see Fig. 5) the centre of the pin 56 and nose 62 are situated exactly or almost exactly in the same line the type wheel rotates around the nose 62 after this nose has come in engagement with the space between two teeth of the toothed wheel 52. If this fulcrum is situated in the plane represented by the line A B of Fig. 5, said line being perpendicular to the plane of the type wheel, the type to be typed strikes perpendicularly on the paper and on the platen 64. The plane through the line A B must touch the platen at the point at which the type wheel comes in contact with the platen when striking.

This idea of the invention may be carried out in various manners. In the embodiment shown in Figs. 5 and 6 the toothed wheel 52 keyed on the same shaft as the type wheel 50 is of much larger diameter than said type wheel. With this object in view it must be arranged below or above the platen 64 and be sufficiently distant from the typewheel as shown in Fig. 6. By this simple measure it becomes possible to ensure the perpendicular striking of the type on the platen.

In Fig. 7 the support 65 for the paper has also the shape of a cylinder the axis of which is however parallel with the axis of the type wheel. A type wheel 66 and a toothed wheel 67 are driven by a common shaft 68 which is journaled in a movable lever 69. This lever 69 is fulcrumed at 70. Upon the lever 69 a two-armed lever 71 is mounted which has at the end of one arm a stop nose 72 and at the end of the other arm an armature 73 adapted to be attracted by an electro-magnet 74. When this electro-magnet 74 is excited it attracts the armature 73; the stop nose comes in engagement with the space between two types of the toothed wheel 67 and the type wheel moves in the direction of the arrow 75 towards the platen pivoting around the fulcrum 70 of the lever 69 which draws along the two-armed lever 71. The armature 73 may be arranged as shown in Fig. 7, in such a manner, that the attracting power of the electro-magnet acts perpendicularly with regard to this movement of the lever 71 so that the magnetic force acting upon the armature 73 does not interfere with the movement of the lever 69.

If the fulcrum 70 of the lever 69 is situated in a plane C—D, which touches the platen at the point of contact between it and the typewheel, the typewheel strikes perpendicularly on the surface of the paper.

The form of construction shown in Fig. 7 presents the advantage that the diameter of the toothed wheel need not be greater than that of the typewheel. With the arrangement of the platen 65 shown in Fig. 7 parallel to the axle of the type wheel the use of a larger sized toothed wheel would not be possible.

The electro-magnet may further be mounted on the lever in which the shaft of the typewheel is journaled. In this case the leads for the electro-magnet must be movable.

Figs. 8 and 9 show a further form of construction which operates in a similar manner as that shown in Fig. 7. After a nose 76 has come in engagement with the ratchet wheel the type wheel 77 oscillates around the stationary pivot axle 78. In this case the type wheel is driven by a toothed wheel 80 keyed on the shaft 79 of the type wheel and driven itself from motor 81 through the intermediary of the gear wheels 82 and 83. When the typewheel is not printing, the lever 84 is pressed by the action of a spring 85 against its abutment 86. The form of construction shown in Figs. 8 and 9 possesses the advantage that the direct drive of the typewheel shaft, and consequently the Cardan joint, are suppressed.

I claim:—

1. Electric type writing machine with rotating type wheel comprising in combination a platen, an oscillably mounted shaft, a type wheel on said shaft, a stop wheel on said shaft, a source of power for rotating said type wheel shaft, a friction coupling inserted between said type wheel shaft and said source of power, a Cardan joint inserted in said type wheel shaft, a ring composed of sectors, means for electrically connecting each sector of said ring with one key, a brush on said type wheel shaft sliding upon said ring, a pawl adapted to engage with said stop wheel, a pivot pin on which said pawl is pivotally mounted said pawl being arranged with regard to said platen so that when the pawl engages with the stop wheel said type wheel oscillates towards the platen and strikes against the same, an electro-magnet inserted in the electric circuit and operating said pawl.

2. Electric type writing machine with rotating type wheel comprising in combination a platen, an oscillably mounted shaft, a type wheel on said shaft, a toothed wheel on said shaft serving as stop wheel, a source of power for rotating said type wheel shaft, a rotatably mounted shaft, a toothed wheel on said rotatable shaft gearing with said toothed wheel on said type wheel shaft, a disk on said toothed wheel shaft, an electro-magnet arranged in proximity to said disk, a friction coupling inserted between said

type wheel shaft and said source of power, a Cardan joint inserted in said type wheel shaft, a ring composed of sectors, means for electrically connecting each sector of said ring with one key, a brush on said type wheel shaft sliding upon said ring, and an electric circuit in which said electro-magnet is inserted.

3. Electric type writing machine with rotating type wheel comprising in combination a platen, an oscillably mounted shaft, a type wheel on said shaft, a toothed wheel as stop wheel, a source of power for rotating said type wheel shaft, a friction coupling inserted between said type wheel shaft and said source of power, a Cardan joint inserted into said type wheel shaft, a ring composed of sectors, means for electrically connecting each sector of said ring with one key, a brush on said type wheel shaft sliding upon said ring, a pawl adapted to engage with said stop wheel, an oscillable arm in which said type wheel shaft is mounted, a stud on which said arm is pivoted, said stud and the free end of said pawl being situated in a plane approximately parallel to the type wheel shaft and tangent to said platen.

4. Electric type writing machine with rotating type wheel comprising in combination a platen, an oscillably mounted shaft, a type wheel on said shaft, a stop wheel, a source of power for rotating said type wheel shaft, a friction coupling inserted between said type wheel shaft and said source of power, a Cardan joint inserted into said type wheel shaft, a ring composed of sectors, means for electrically connecting each sector of said ring with one key, a brush on said type wheel shaft sliding upon said ring,

a pawl adapted to engage with said stop wheel, an oscillable arm in which said type wheel shaft is mounted, a stud on which said arm is pivotally mounted, a pivot axle for said pawl fixed on said arm, an electro-magnet for said pawl stationarily arranged and not moving with said arm, the stud of said arm and the free end of said pawl being mounted in a plane approximately parallel to said type wheel shaft and tangent to said platen.

5. Electric type writing machine with rotating type wheel comprising in combination a platen, an oscillably mounted shaft, a type wheel on said shaft, a stop wheel, a source of power for rotating said type wheel shaft, a friction coupling inserted between said type wheel shaft and said source of power, a Cardan joint inserted into said type wheel shaft, a ring composed of sectors, means for electrically connecting each sector of said ring with one key, a brush on said type wheel shaft sliding upon said ring, a pawl adapted to engage with said stop wheel, an oscillable arm in which said type wheel shaft is mounted, a stud on which said arm is pivotally mounted, a pivot axle for said pawl fixed on said arm, an electro-magnet for said pawl also mounted on said arm, the pivot stud for said arm and the free end of said pawl being situated in a plane approximately parallel to the type wheel shaft and tangent to the platen.

In testimony whereof I affix my signature in presence of two witnesses.

ARTHUR SCHERBIUS.

Witnesses:

WLAD. ENDERS,
RIEGER L. ANSPACH.