



STAT

CO-8 Morse Code Writer

and

CA-3 Tape Cartridge

A. Introduction

1. The CO-8 is used to write Morse code messages on the magnetic tape of the CA-3 cartridge. These messages are then transmitted at high speed when the CA-3 is placed in a keyer. The keyer may be a separate unit or it may be built into the transmitter.

2. There is nothing to wind, adjust or tune on either the CO-8 or CA-3. No battery or electric power is required. The tape is advanced by the writer or keyer and automatically rewound by the CA-3 when the cartridge is removed from either unit. Tape stops on the cartridge prevent overrunning the end of the tape.

3. To record a message, only four simple operations are required: place the CA-3 on the CO-8; turn the dial to the character desired; place the CO-8 handle in the full up position and then pull to the full down position; press the space button once between each group of the message. Spaces between characters are automatically inserted by the CO-8.

B. RECORDING A MESSAGE

1. Place a completely erased cartridge in place over the tape head of the CO-8 as shown in Illustration 4. Press the cartridge firmly down over locking pins 5 and 8 (Illustration 3) making certain that the cartridge tape drive gear meshes properly with the CO-8. Press and release the space button a few times to insure proper tape movement. Each time the space button is depressed, the tape should move a very slight amount. Press the extension handle release and fold out the extension handle. Place the CO-8 on a flat, smooth surface.

2. With the extension handle in the down position, rotate the dial so that the desired character is directly underneath the white index mark. With one hand steadying the CO-8, raise the handle as far as it will go, then pull the handle down as far as it will go. Do not hesitate on the downstroke; use a smooth, even stroke. The character has now been recorded on the tape. Record each character in this manner. Press the space button once for spacing between each group.

3. Before recording the first message, practice the operation of the CO-8. Fast and accurate recording of messages with smooth and unhesitating downward strokes of the handle can be accomplished with just a little practice. Although characters can be dialed with the handle in either the up or down position, it is less awkward to dial the characters when the handle is in the down position. Never dial a

character except when the handle is either in the full up or full down position or the CO-8 may be damaged.

4. Never remove the CA-3 tape cartridge during the process of recording a message. If the cartridge is accidentally removed, the tape must be completely erased and the message recorded from the beginning.

C. REMOVAL OF CARTRIDGE FROM WRITER

Press the cartridge release button shown in Illustration 4 and remove the cartridge from the recorder. Immediately upon releasing the cartridge, the tape will automatically rewind and the message will be ready for transmission. If the weather is extremely cold, insure that the cartridge has fully rewound by pushing on the puller tape spool.

D. PRECAUTIONS AND LIGHT MAINTENANCE

1. The CO-8

a. Inspect the magnetic tape head (Illustration 3, Fig. 7) frequently for cleanliness. If dirt or gum is found, clean with a soft, lintless cloth.

b. Do not oil any part of the CO-8.

c. Do not remove the cover of the writer or attempt to make any adjustments unless the writer fails completely.

2. The CA-3

a. If the cartridge contains lint, dust, or other foreign matter, clean it by blowing on it lightly or by brushing with a soft, clean, dry brush.

b. Do not oil any part of the CA-3.

c. To prevent tape damage, avoid touching the magnetic tape.

d. Under normal use, the magnetic tape should last indefinitely. If for any reason it is necessary to replace the tape, follow the procedure given below:

(1) Remove the three screws from the cartridge side cover nearest to the tape spools and remove the side cover. See Illustration 1.

(2) Refer to Illustration 2. Remove the end of the tape from the puller spool and pull the tape from the supply spool. When the end of the tape is reached, hold the supply spool and remove the tape. Do not allow the supply spool to run free, but brake it with one finger

and permit it to rewind slowly.

(3) Remove any glue or adhesive tape remaining on the spools.

(4) Prepare $12\frac{1}{2}$ feet (3.8 metres) of the highest available grade of magnetic tape. Preferably clean, unused tape should be used.

(5) Turn the supply spool clockwise until it stops and hold it against the stop. Using a small piece of adhesive tape, attach the end of the tape to the spool. The shiny side of the tape must be against the spool. After the tape is installed, the dull side must fit directly against the tape head of the writer or keyer.

(6) After attaching the tape to the supply spool and while still holding the spool against the stop, wind about $1\frac{1}{2}$ turns of the tape around the spool. Then allow the supply spool to self-wind the tape until it stops. Carefully control the rewind speed by braking the spool with the finger.

(7) With the supply spool fully rewound, cut off excessive tape by leaving about three inches (7.6 cm) extending from the bottom of the cartridge.

(8) Turn the puller spool counter-clockwise until it stops.

(9) Thread the tape over the guide posts as shown in Illustration 2. While holding the puller spool against its stop, first fasten the end of the tape to the spool with adhesive, then wind it about $1\frac{1}{2}$ times around the spool.

(10) Check the operation of the cartridge by turning the drive gear until the tape is completely wound from the supply spool to the puller spool, then release the gear and check to determine that the tape rewinds smoothly.

(11) Replace the cartridge side cover and the three screws.

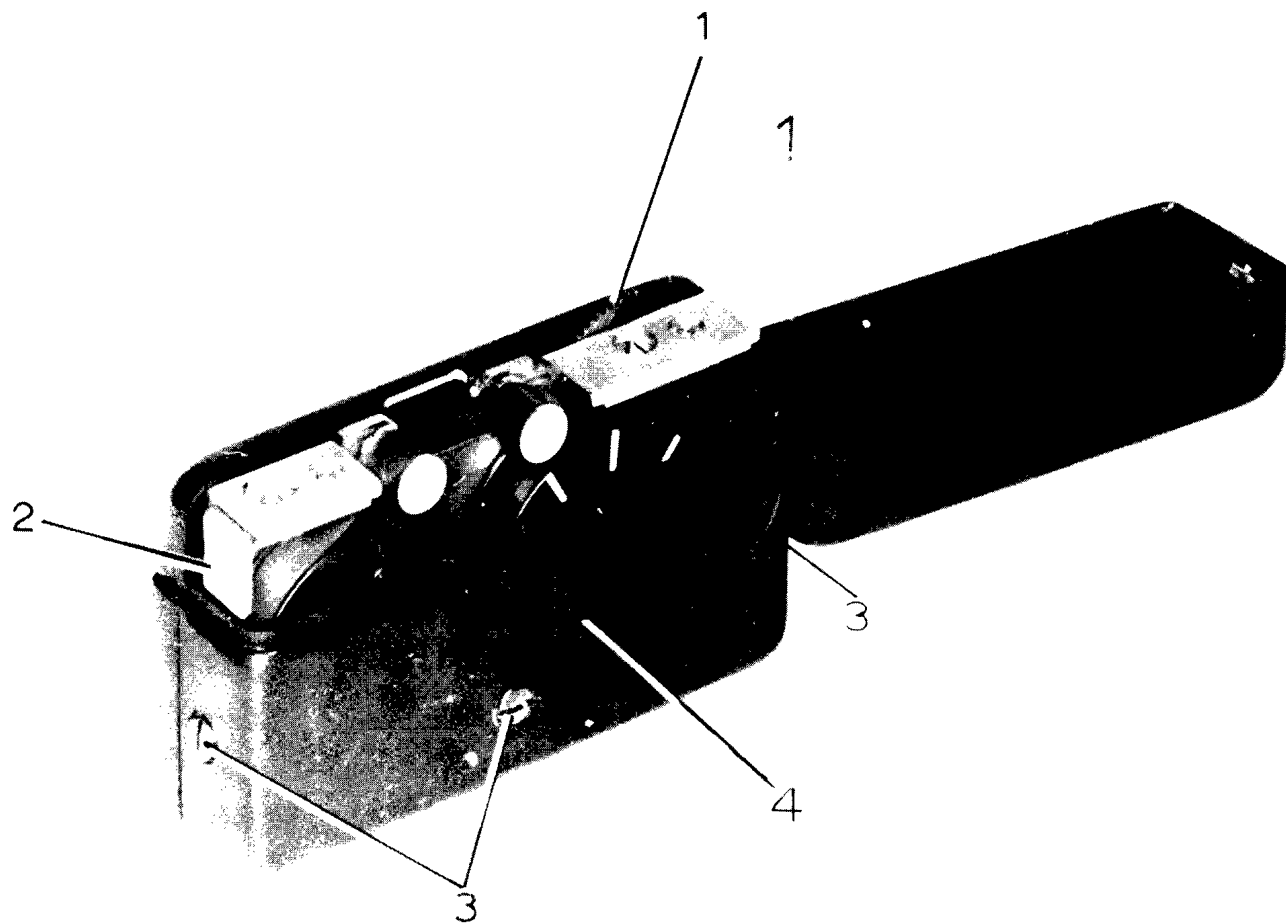

Illustration 1 CA-3 Cartridge

1. Tape Drive Gear
2. Cartridge Release Button
3. Three Screws To Remove Side Cover
4. Side Cover

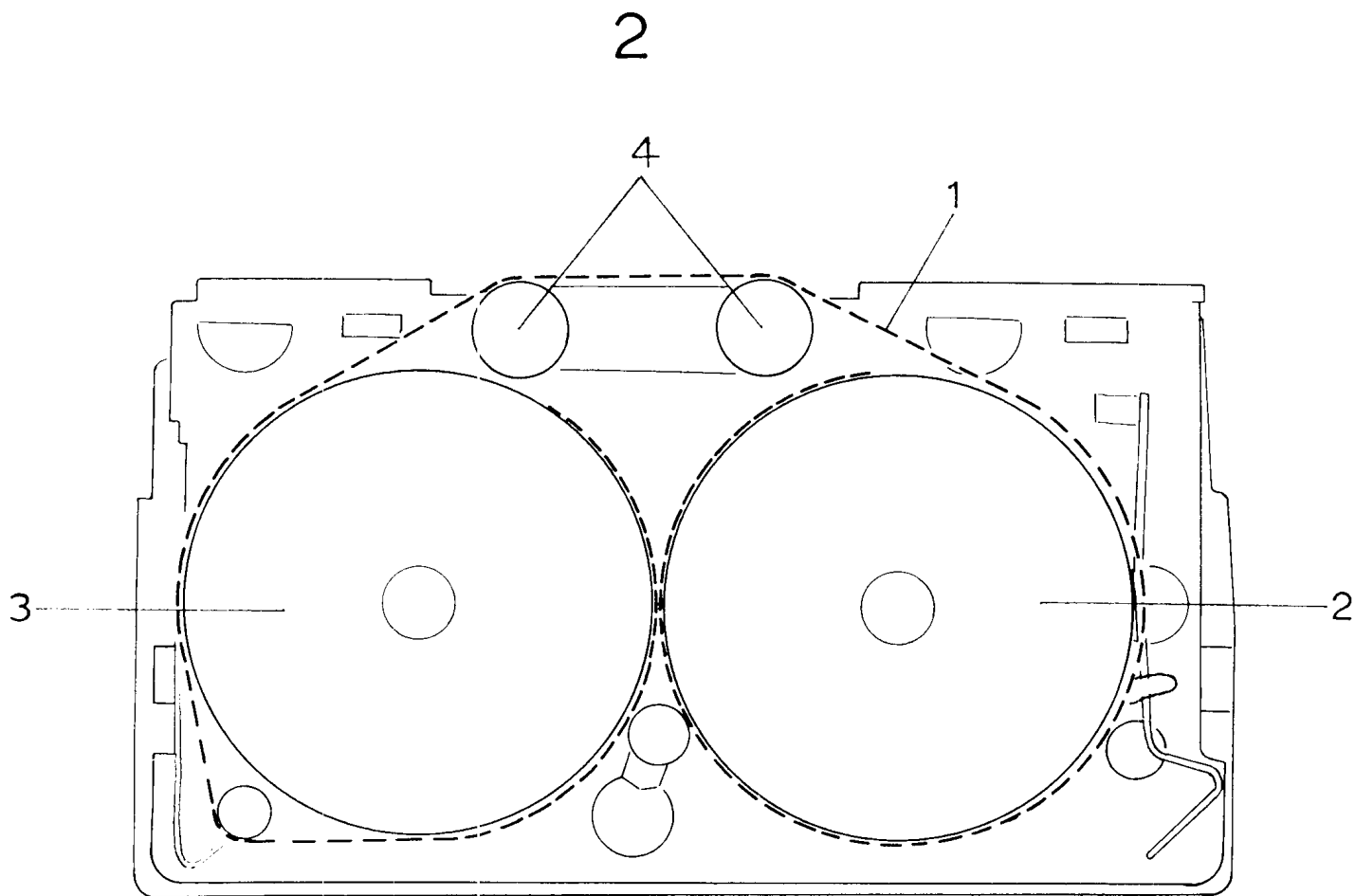

Illustration 2 Drawing of Exposed CA-3

- 1. Magnetic Tape
- 2. Puller Tape Spool
- 3. Supply Tape Spool
- 4. Guideposts

3

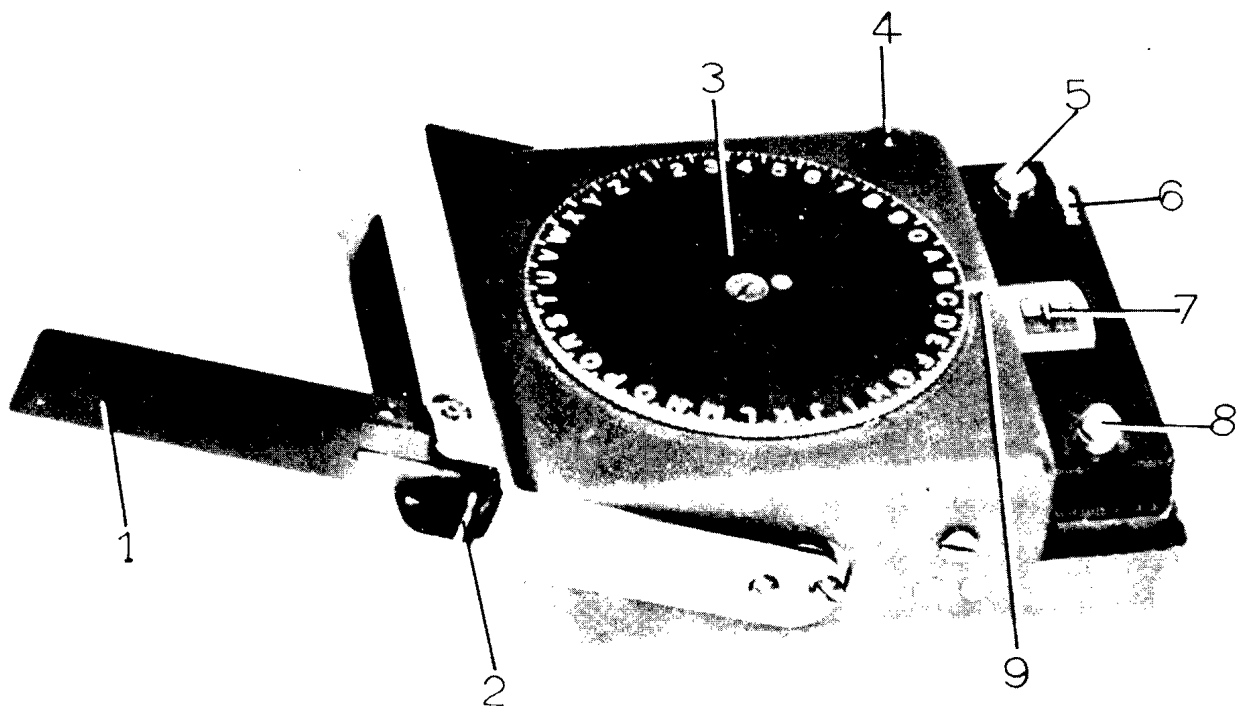

Illustration 3 CO-8 Morse Code Writer

1. Extension Handle
2. Extension Handle Release
3. Alphabet-Numerical Dial
4. Space Button
5. Tape Cartridge Locking Pin
6. Tape Drive Gear
7. Magnetic Tape Head
8. Tape Cartridge Locking Pin
9. Index Mark

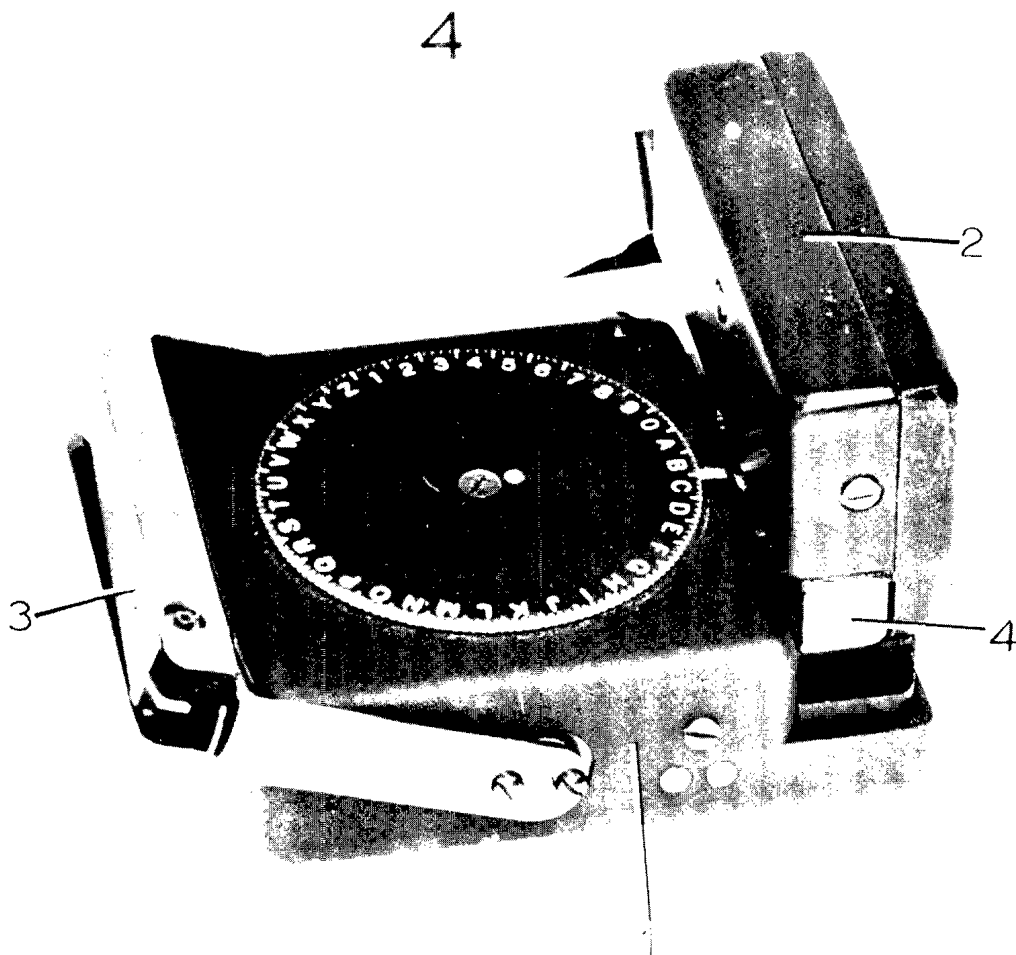

Illustration 4 CO-8 Writer With CA-4 Cartridge Attached

1. CO-8 Morse Code Writer
2. CA-3 Cartridge
3. Extension Handle Recessed
4. Cartridge Release Button

STAT



KE-8 Keyer

A. INTRODUCTION

The KE-8 is a Morse Code keyer capable of keying a radio transmitter at a high speed. The function of the KE-8 is to pull the CA-3 cartridge tape across the keyer reading head and key the transmitter with the message written on the tape. The keyer includes an IDY function for sending a continuous train of dots for base station tuning purposes. It also contains a provision for erasing tapes. The KE-8 requires an input of 12 volts DC which it obtains from the associated transmitter.

B. KEYER CONNECTION

Refer to Illustration 1.

1. A single connector receptacle (12) provides power to the keyer and keyer output to the transmitter. Normally, a cable connects the keyer to the associated transmitter, or to the keyer adaptor unit.

2. Connect the keyer plug from the equipment to the KE-8 connector receptacle 12.

C. MESSAGE PREPARATION

Prepare a message on an erased CA-3 cartridge tape as instructed in your Morse Code Writer Instructions.

D. MESSAGE TRANSMISSION

1. Turn the KE-8 motor ON-OFF switch (10) to OFF.

2. Lift out the wind-up crank (8) and wind it clockwise until the tape drive gear (3) rotates. When the drive gear rotates, this indicates that the spring motor is fully wound.

3. Attach the CA-3 cartridge over KE-8 locking pins 4 and 6. Press the cartridge firmly down over the locking pins making certain that the cartridge tape drive gear meshes properly with the KE-8 tape drive gear.

4. Tune the transmitter and set the transmit operating switch in the TRANSMIT position (or in the automatic key position) as instructed in your transmitter instructions.

5. To transmit an IDY signal, press the spring-loaded IDY switch (11) upward and hold it against its stop the required number of seconds given in your operating procedure instructions. The transmitter output indicator should show that the transmitter is now operating. At the end of the IDY period, release the IDY switch and it will automatically return to the OFF position.

6. To transmit the cartridge, slide the KE-8 motor ON-OFF switch (10) to the ON position. The transmitter output indicator will fluctuate during the time that the message is on the cartridge tape. When the transmitter indicator stops fluctuating, showing that the message has been fully transmitted, slide the KE-8 motor switch to OFF.

7. Remove the CA-3 from the KE-8 and allow the cartridge tape to automatically rewind. Fully rewind the KE-8 motor before replacing the cartridge on the keyer. **WARNING:** The CA-3 must always be removed before winding the KE-8 or the cartridge tape may be torn from the tape spool.

8. The IDY signal and the message may be repeated any number of times by following the directions given above.

E. TAPE ERASING PROCEDURE

1. Connect the transmitter or equipment keyer plug to the KE-8 as instructed above. The transmitter must have power supplied and the transmitter operating switch must be placed in the RECEIVE, ON or OFF position as specified in your transmitter instructions.

2. Remove the CA-3 cartridge from the KE-8 and allow the tape to rewind. Fully wind the KE-8 then replace the cartridge.

3. Slide the erase switch (9) upward in the direction of the arrow and hold it firmly against its stop. Then slide the motor ON-OFF switch to the ON position. The erase switch will lock in the upward, or erase position. After the tape has run completely through its length and stops (the KE-8 motor will also stop), slide the motor switch to the OFF position. The erase switch will automatically return to the OFF position.

4. Remove the CA-3 cartridge and allow the tape to rewind. The cartridge may now be used to write a message on the Morse Code Writer.

5. **CAUTION:** If the KE-8 motor is stopped at any time during the erasing period, the cartridge must be removed from the keyer and the erasing procedure repeated entirely. To insure a fully-wound spring, always wind the KE-8 before inserting a tape cartridge.

F. REMOVAL OF POWER

To remove power from the KE-8, remove the equipment keyer plug from receptacle (12).

Illustration 1 - KE-8 Keyer

- | | |
|--------------------|--------------------------|
| 1. Top Cover | 7. Lid |
| 2. Bottom Cover | 8. Wind-Up Crank |
| 3. Tape Drive Gear | 9. Erase Switch |
| 4. Locking Pin | 10. Motor ON-OFF Switch |
| 5. Reading Head | 11. IDY Switch |
| 6. Locking Pin | 12. Connector Receptacle |

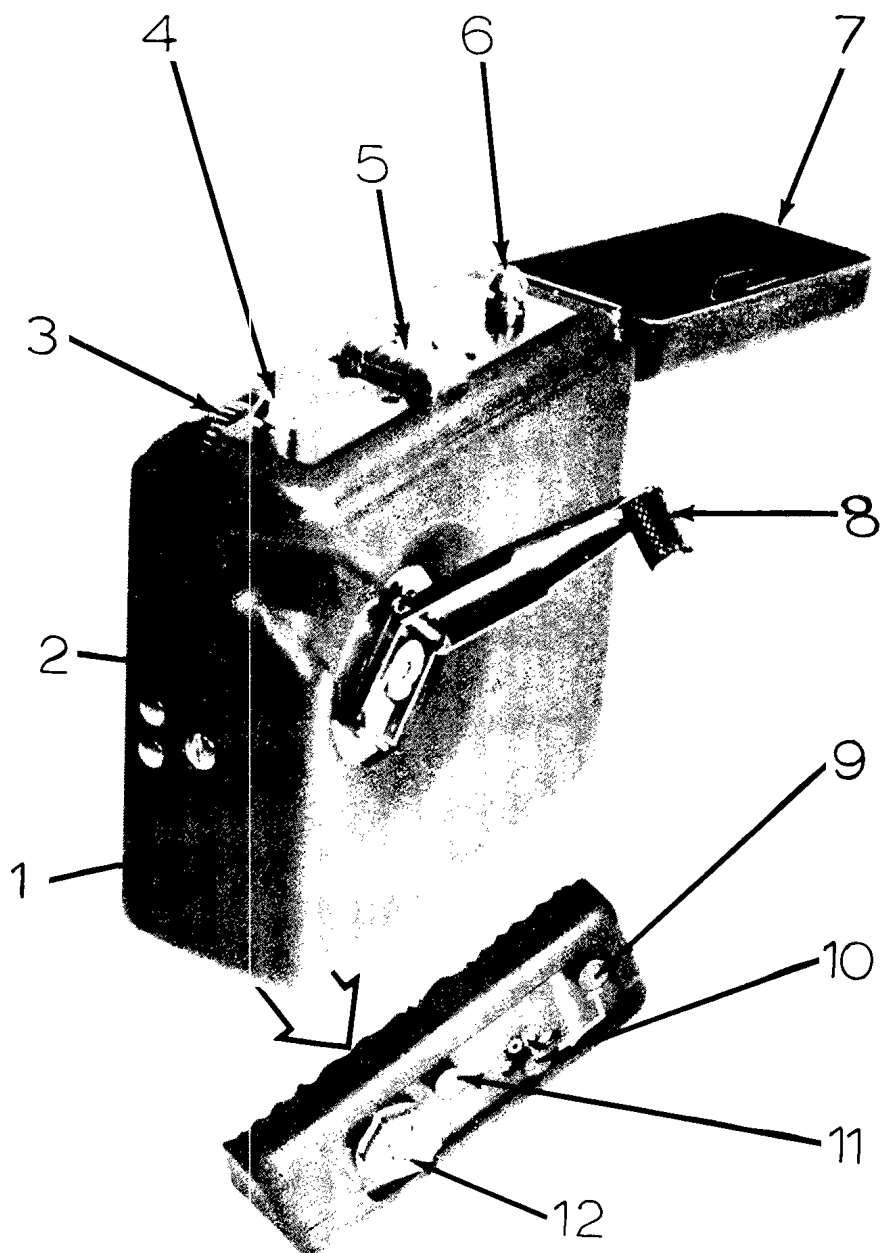

Illustration 2 - Exposed KE-8 Keyer

- | | |
|-----------------------------|-------------------------------|
| 1. Motor Speed Adjust Screw | 5. Reading Head |
| 2. Wind-Up Crank | 6. Locking Pin |
| 3. Locking Pin | 7. Electronic Circuit Boards |
| 4. Tape Drive Gear | 8. Reading Head Adjust Screws |

*Lubricating Points

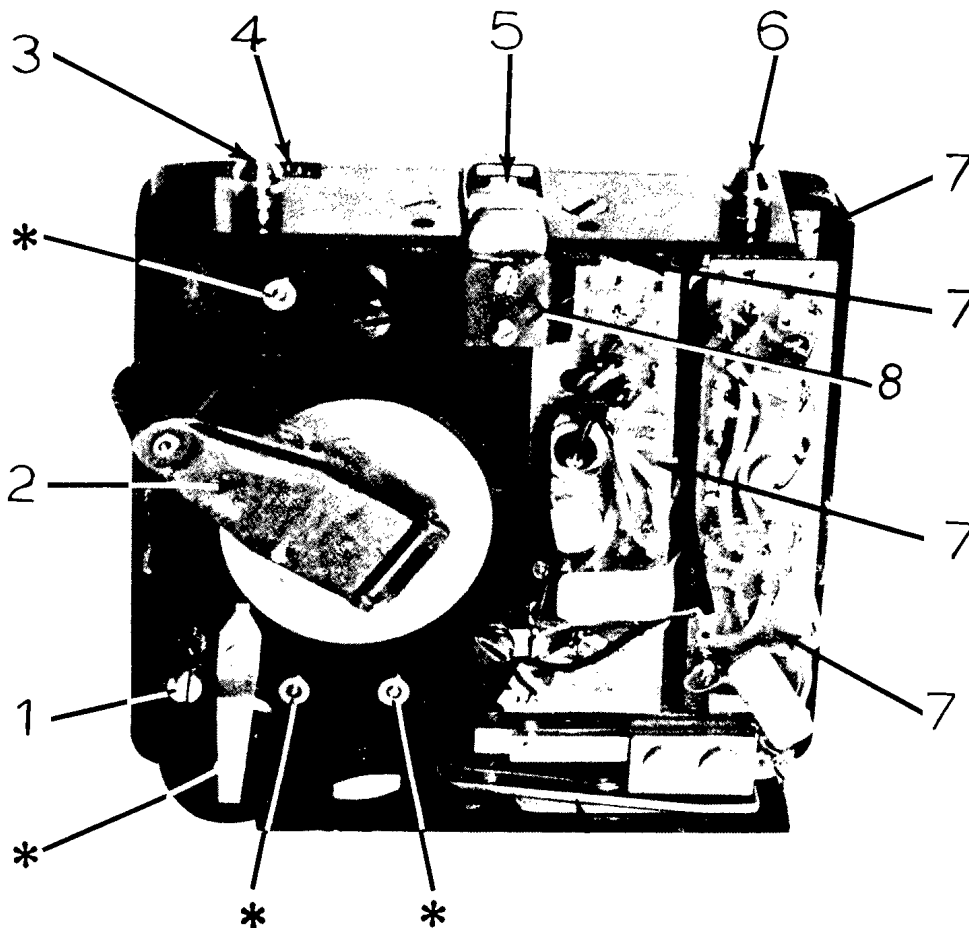
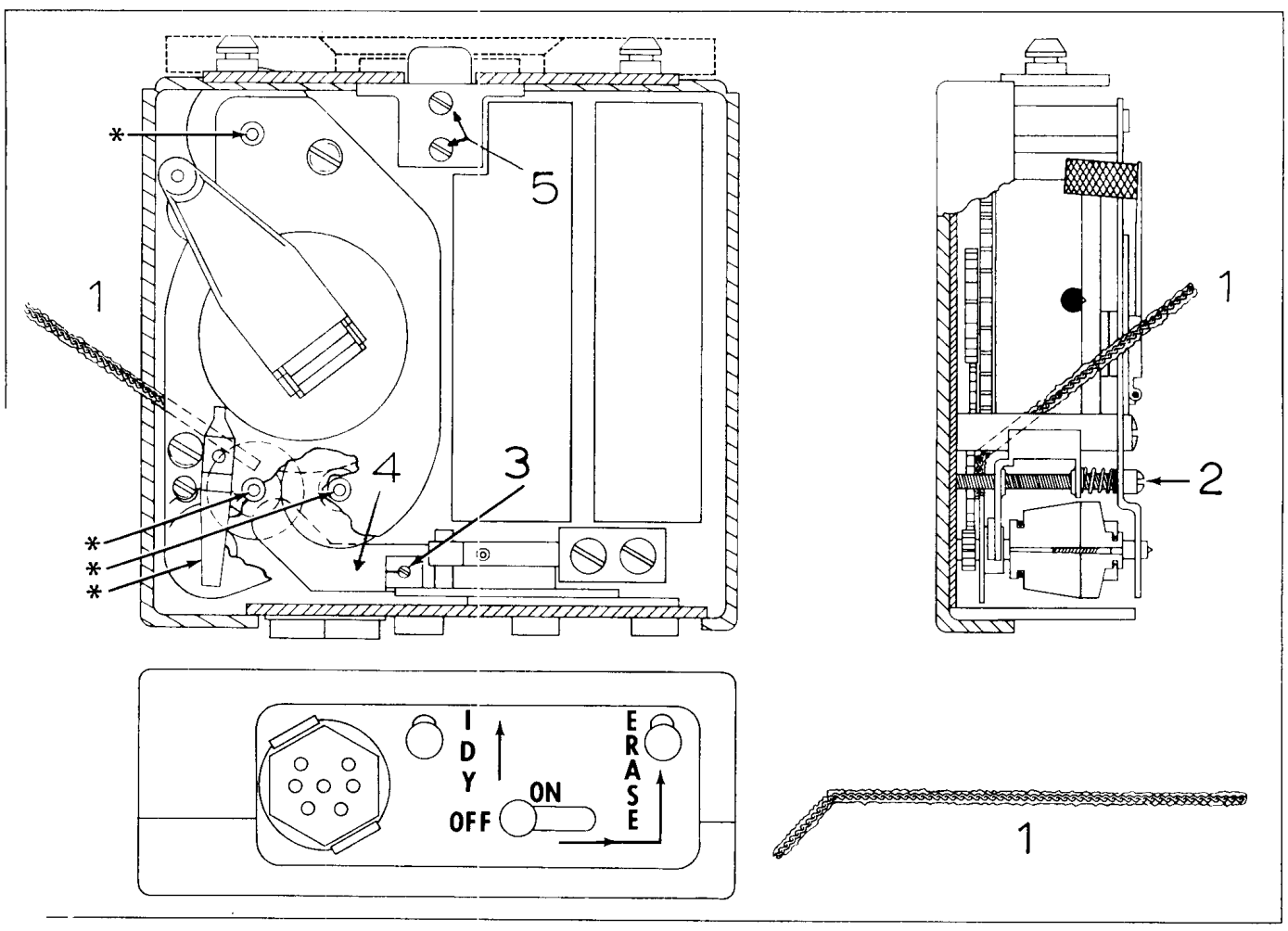

Illustration 3 - KE-8 Drawing

- 1. Pipe Cleaner
- 2. Motor Speed Adjust Screw
- 3. Brake Finger Adjust Screw
- 4. Brake Finger
- 5. Reading Head Adjust Screw
- * Lubricating Points



G. KEYSER TROUBLE CHECKS

Other than keeping the reading head (5) clean by wiping with a soft, lintless cloth, maintenance to internal parts of the keyer is not recommended. Adjustment and repair of the KE-8 is difficult and should be performed by trained electronic technicians. As long as you are able to transmit messages to the satisfaction of the base station, do not open the keyer cover to expose the internal parts. If difficulty is encountered, first check your transmitter, battery, antenna, and repeat the checks until you are certain that the trouble is not in another piece of equipment.

1. Keyer Operation by Observation

a. Fully wind the keyer and check that each control operates as described in paragraphs D and E. Check the transmitter output indicator fluctuations at the time you transmit a message to base. After erasing the cartridge at the conclusion of a base contact, transmit the erased cartridge as you would a message. If the cartridge is fully erased, the transmitter output indicator will not fluctuate and you will not transmit a signal.

b. If any of the above tests fail, check to determine that the equipment keyer plug is making good contact into connector receptacle (12). If possible, check the battery voltage reading at the transmitter.

2. Reading Head Alignment Check

a. The reading head (5) should be positioned so that the cartridge tape fits exactly between the grooved slot, and so that the tape has a slight pressure against the head when the cartridge is in place. Gently and slowly fit the cartridge in place over the keyer and observe that the tape falls exactly in place between the grooved slot. Observe that the reading head is sufficiently raised to allow a slight pressure on the tape with the cartridge locked in place.

b. The height of the reading head may be checked as follows:

(a). First remove the hinged lid. To do this, open and swing the lid back fully, then slide the lid off the hinge pin. The metal thickness of the lid may now be used to check the height of the reading head.

(b). The white metal strip along the edges of the grooved slot is raised to about the thickness of the keyer lid. The height of the reading head is measured from the black metal top plate to the top of the white metal strip on both sides of the

grooved slot. Merely hold the edge of the lid against the side of the grooved slot and check that the thickness of the lid is about the same height as the white metal strip. The lid may be just slightly higher, which is normal.

3. Keyer Motor Speed Check

Incorrect motor speed will effect the keying. The keyer motor speed may be checked as follows:

a. With the keyer motor ON-OFF switch in the OFF position, wind the motor to full power.

b. If not already marked, mark a piece of white adhesive tape to the takeup spool of a CA-3 cartridge so that the tape is visible when the cartridge is attached to the keyer.

c. Attach the cartridge to the keyer.

d. Slide the motor switch to ON and count the number of revolutions made by the takeup spool in 20 seconds. If the spool revolves between 18 and 28 revolutions in 20 seconds, the motor speed is satisfactory.

H. LIMITED MAINTENANCE TO KE-8

ONLY IF YOU ARE CERTAIN THAT YOU HAVE TROUBLE INSIDE THE KEYER, PROCEED WITH THE FOLLOWING:

1. Remove power from the keyer.

2. Keyer Cover Disassembly

Removal of the lid and top cover (Illustration 1, Lines 1 and 7) are necessary to accomplish the maintenance given below. Further disassembly of the keyer components is not recommended.

a. Remove the hinged reading head lid.

b. Remove the two screws from the right and left sides of the keyer.

c. Unfold the wind-up handle to a straight up-and-down position, Carefully lift off the cover to expose the internal mechanism, as shown in Illustration 2. Fold the wind-up crank back down into the upper left-hand corner to avoid damage to the electronic circuit boards.

3. Visual Check and Cleaning of Keyer

a. Carefully make a visual check to determine that there are no broken wires or parts. Check the connector receptacle for broken pins or wires. Repair as necessary.

b. Internal parts may be cleaned by blowing out dust and small particles of dirt. If available, a small, dry, SOFT brush may be used for cleaning circuit boards and other parts.

4. Lubricating the Motor

Fully wind the spring motor and check the mechanical operation of the keyer. If it appears that oiling is necessary for smooth operation, proceed as follows: Use a thin oil, similar to a good grade sewing machine oil. Apply SPARINGLY (a very small drop) to each exposed pivot bearing as shown in Illustrations 2 and 3. Remove excess oil with a dry, lintless cloth. Do not allow oil to run into the brake mechanism or onto the governor disc. DO NOT USE OIL UNLESS NECESSARY; IF YOU USE OIL, USE VERY LITTLE.

5. Keyer Motor Speed Adjustment

First check the motor speed with the CA-3 cartridge as given above. If the drive motor runs slower than 18 revolutions, or faster than 28 revolutions in 20 seconds, the speed may be adjusted as follows: Turn the speed-adjust screw (Illustration 2, Line 1) clockwise to increase motor speed and counterclockwise to decrease motor speed. Turn the screw no more than $\frac{1}{4}$ turn each time, then check the motor speed. A setting of from 23 to 25 revolutions (of the CA-3 take-up spool) is optimum motor speed.

6. Motor ON-OFF Switch Inoperative

If the motor does not stop when the ON-OFF switch is turned to OFF, or the keyer will not uniformly unwind the CA-3 cartridge, the cause and remedy may be as follows:

Refer to Illustration 3.

a. Grease or dirt on the brake disc surface. Clean the brake disc surface with cleaning alcohol while the motor is running. As shown in Illustration 3, the brake disc surface may be reached with a slightly bent pipe cleaner by inserting the cleaner between the motor spring drum and the post on which the governor control is mounted. If a suitable cleaning agent cannot be found, use a dry pipe cleaner.

b. Motor brake is out of adjustment. To adjust the brake, proceed as follows: When the ON-OFF switch is in the OFF position, the small brake finger adjust screw (Illustration 3, Line 3) can be seen at the bottom of the keyer. The screw cannot be seen when the switch is in the ON position. If the motor moves (or creeps) in the fully wound position when the ON-OFF switch is OFF, slightly adjust the brake finger adjust screw clockwise. If the motor will not fully unwind, adjust the screw SLIGHTLY counterclockwise. In the OFF position, the motor should not move or creep with a cartridge in place or removed.

7. Reading Head Adjustment

a. The reading head is difficult to adjust correctly and adjustment should not be attempted unless absolutely necessary. If the previously given keyer trouble checks and maintenance procedures have failed to correct the trouble, and the reading head is out of alignment, proceed as follows:

b. Remove the top cover by removing the two screws from the right and left sides of the keyer. Remove the bottom cover by removing the four screws from the face of the cover. Shown in Illustration 2, Line 8 and Illustration 3, Line 5 are two screws that hold the reading head in place. Also, directly on the other side of the keyer is one more screw that holds the head in place. This screw on the back side of the keyer is countersunk; that is, inside a small hole.

c. First slightly loosen the two screws in the front (Illustration 2, Line 8). Raise or lower the reading head as required. If the reading head will not move, slightly loosen the screw in the back. Adjust the position of the reading head as given in paragraph G-2. It may be necessary to slightly tighten each screw (place a little tension on the reading head) as adjustment is being made. After proper adjustment of the reading head is made, firmly tighten all three screws. Replace the bottom cover first, then replace the top cover.